



The National Coal Council
Power for America from America

Reliable & Resilient

The Value of Our Existing Coal Fleet

**An Assessment of Measures to Improve
Reliability & Efficiency While Reducing Emissions**



May 2014



The National Coal Council
Power for America from America

Reliable & Resilient
The Value of Our Existing Coal Fleet
An Assessment of Measures to Improve
Reliability & Efficiency While Reducing Emissions

May 2014

NCC CHAIR

John Eaves

Arch Coal, Inc.

COAL POLICY COMMITTEE CHAIR

Fredrick D. Palmer

Peabody Energy

STUDY CHAIR

Jeff Wallace

Southern Company Services

TECHNICAL WORK GROUP CHAIR

Steve Wilson

Southern Company

LEAD AUTHORS

Doug Carter

J. Edward Cichanowicz

Stu Dalton & EPRI Team

NCC EXECUTIVE VICE PRESIDENT & CHIEF OPERATING OFFICER

Janet Gellici

The National Coal Council is a Federal Advisory Committee to the U.S. Secretary of Energy. The NCC advises, informs and makes recommendations to the Secretary on matters requested by the Secretary relating to coal or the coal industry.

Library of Congress Catalog # TBD

The National Coal Council

The National Coal Council (NCC) was chartered in 1984 based on the conviction that an industry advisory council on coal could make a vital contribution to America's energy security. NCC's founders believed that providing expert information could help shape policies relevant to the use of coal in an environmentally sound manner. It was expected that this could, in turn, lead to decreased dependence on other less abundant, more costly and less secure sources of energy.

These principles continue to guide and inform the activities of the Council. Coal has a vital role to play in the future of our nation's electric power and energy needs. Our nation's primary energy challenge is to find a way to balance our social, economic and environmental needs.

Throughout its 30-year history, the NCC has maintained its focus on providing guidance to the Secretary of Energy on various aspects of the coal industry. NCC has retained its original charge to represent a diversity of perspectives through its varied membership and continues to welcome members with extensive experience and expertise related to coal.

The NCC serves as an advisory group to the Secretary of Energy, chartered under the Federal Advisory Committee Act (FACA), providing advice and recommendations to the Secretary of Energy on general policy matters relating to coal and the coal industry. As a FACA organization, the NCC does not engage in lobbying activities.

The principal activity of the NCC is to prepare reports for the Secretary of Energy at his/her request. During its 30-year history, the NCC has prepared more than 30 studies for the Secretary, at no cost to the Department of Energy. All NCC studies are publicly available on the NCC website.

Members of the NCC are appointed by the Secretary of Energy and represent all segments of coal interests and geographic distribution. The NCC is headed by a Chair and Vice Chair who are elected by the its members. The Council is supported entirely by voluntary contributions from NCC members and receives no funds from the federal government. Studies are conducted solely at the expense of the NCC and at no cost to the government.

The National Coal Council values the opportunity to represent the power, the pride and the promise of our nation's coal industry.



The Secretary of Energy
Washington, DC 20585

January 31, 2014

Mr. John Eaves
Chairman, The National Coal Council
1730 M Street NW, Suite 907
Washington, DC 20036

Dear Chairman Eaves:

I am writing today to request that the National Coal Council (NCC) conduct a new study that assesses the existing U.S. coal fleet. In order to meet U.S. economic, energy and environmental goals, power generators are interested in pursuing opportunities to improve the capacity, efficiency and emissions profiles of existing coal assets employing performance optimization tools, techniques and technology retrofits.

The assessment of the existing U.S. coal fleet would address the following question: What can industry and the Department of Energy, separately and jointly, do to facilitate enhancing the capacity, efficiency and emissions profiles of the existing coal generation fleet in the United States through application of new and advanced technology? Such a study would also address the jobs implications of modification and addition of equipment at existing coal fired power plants.

Upon receiving this request and establishing your internal study working groups, please advise me of your schedule and work plan for completion of this study.

Sincerely,

A handwritten signature in black ink, appearing to read "Ernest J. Moniz".

Ernest J. Moniz



The National Coal Council
Power for America from America

February 14, 2014

The Honorable Dr. Ernest Moniz
U.S. Secretary of Energy
U.S. Department of Energy
1000 Independence Ave., SW
Washington, DC 20585

Dear Mr. Secretary:

On behalf of the members of the National Coal Council (NCC), I am pleased to accept your request that the NCC conduct the study you requested in your letter dated January 31st, 2014. Activity has begun on preparing this study which will provide an assessment of the existing U.S. coal fleet and the job implications of modifications and technology solutions in pursuit of enhancing the capacity, efficiency and emissions profile of the fleet.

NCC Vice Chair, Jeff Wallace, Vice President of Fuel Services for Southern Company, will serve as the Council Chair for this study. Steve Wilson, General Manager of Research and Development, Southern Company, will Chair the Study Work Group.

The Study Work Group has targeted a completion date for this study of early May 2014. The spring meeting of the NCC has been approved by Principal Deputy Assistant Secretary Chris Smith for Wednesday, May 14th, 2014. The study will be presented for the NCC membership's approval at the May 14th meeting.

NCC's leadership looks forward to meeting with you to discuss the existing coal fleet study. Please let us know when you would like to meet.

Thank you for your support of the National Coal Council. We look forward to completing the requested study in a timely manner for use in the continuing dialogue on issues related to our nation's energy future.

Sincerely,

John W. Eaves



The National Coal Council ***Power for America from America***

May 14, 2014

The Honorable Dr. Ernest Moniz
U.S. Secretary of Energy
U.S. Department of Energy
1000 Independence Ave., SW
Washington, DC 20585

Dear Mr. Secretary:

On behalf of the members of the National Coal Council (NCC), we are pleased to submit to you pursuant to your letter dated January 31st, 2014, the report "Reliable and Resilient: The Value of Our Existing Coal Fleet." The study's primary focus was to assess what industry and the Department of Energy, separately and jointly, can do to enhance the capacity, efficiency and emissions profile of the existing coal generation fleet in the United States through the application of new and advanced technology. The study also examines the job implications of modification and addition of equipment at existing coal power plants. Other issues addressed in the report include benefits afforded by the existing fleet and changes that could impact those benefits in the future.

The NCC study was conducted during the winter of 2013-2014. The severe cold weather events experienced while the study was underway reinforced the importance of retaining and maintaining coal generation assets in order to reliably and affordably meet the electricity needs of U.S. residents and businesses. The major lesson learned from the Polar Vortex experience is that the availability and operation of coal units now scheduled for retirement over the next two years enabled the power sector to meet demand during periods of harsh weather.

NCC's assessment of the existing U.S. coal fleet supports the findings that:

- The current 310 GW fleet of coal-fired power plants underpins economic prosperity in the U.S., providing direct economic and macroeconomic benefits; energy supply and price stability; environmental benefits through continuous technology advancements; and job-creating opportunities.
- Coal plant closures and increasing reliance on natural gas for power generation will adversely impact price stability and resource supply.
- New Source Review (NSR) regulations adversely impact generators' decisions and ability to enhance plant efficiency, reduce emissions and improve overall operations and capacity.
- Collaborative RD&D efforts (DOE and industry) can enhance the ability of the coal fleet to improve its flexibility and reliability, to increase its efficiency and to reduce its emissions profile.

The need for RD&D is vital to support marketplace shifts and public policy objectives:

- Increasing deployment of intermittent renewable energy technologies, competition from other fossil fuels, use of non-design coals and continued use of older coal generation technologies will lead to increased operation of base load units in a cycling mode for which they were not designed.
- Modest improvements in efficiency are possible with existing technologies to improve heat transfer, reduce heat losses and make better use of low quality heat. More advanced improvements, if technically and commercially viable, could significantly enhance efficiency.
- Challenges arise in complying with emerging regulations for control of traditional pollutants when new control regimes create secondary, follow-on emissions issues.
- Existing coal plants were not designed or located with CCS in mind; the ability to retrofit these plants for CCS is problematic. More research is needed to commercialize CCS retrofit potential; improved efficiencies provide an interim path in the meantime.

The U.S. benefits from having a diverse portfolio of electricity sources. The Energy Information Administration (EIA) projects very little new coal capacity will be built in the U.S. through 2040. Therefore, maintaining coal's role in this diversified portfolio will likely rest on industry's ability to continue safe and economical operation of the existing fleet, while making the changes necessary to ensure continued environmental compliance.

Past challenges to coal generation, such as the need to reduce emissions of sulfur dioxide, nitrogen oxides and mercury, were met through collaborative efforts between the public sector and the private sector to develop new technologies. The question posed by this report is – Can this be done again? The National Coal Council believes that “Yes, it can be done and yes, it must be done.”

Thank you for the opportunity to conduct this study and produce this report. The Council stands ready to address any questions you may have on the recommendations it contains.

Sincerely,

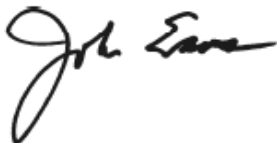
A handwritten signature in black ink, appearing to read "John W. Eaves". The signature is fluid and cursive, with a large initial "J" and a long, sweeping underline.

John W. Eaves
NCC Chair
(May 2012-May 2014)

Reliable & Resilient

The Value of Our Existing Coal Fleet

Study Work Group & Review Team

EXECUTIVE MANAGEMENT TEAM

Jeff Wallace, Southern Company Services – Study Chair
Fred Palmer, Peabody Energy – Coal Policy Committee Chair
Bill Brownell, Hunton & Williams – Coal Policy Committee Vice Chair

TECHNICAL WORK GROUP CHAIR

Steve Wilson, Southern Company

STUDY LEADERSHIP TEAM

Steve Wilson, Southern Company – Study Technical Chair
Doug Carter, Independent Energy Consultant – Lead Author
J. Edward Cichanowicz, Independent Engineering Consultant – Principal Author
Stu Dalton, EPRI – Principal Author
Janet Gellici, National Coal Council

STUDY REVIEW TEAM

Don Gaston, PSEG Fossil
Matt Usher, American Electric Power
Mark Wilson, Tri-State Generation & Transmission

Todd Adkins, Patriot Coal
Sy Ali, Clean Energy Consulting
Janos Beer, MIT
Roger Bezdek
Management Information
Services Inc. (MISI)
Lisa Bradley, AECOM
Frank Clemente, Penn State
Chase Crawford, Southern Company
Mike Durham, ADA-ES
Fred Eames, Hunton & Williams
Clark Harrison, CH2M Hill

Bob Hilton, ALSTOM Inc.
Makram Jaber, Hunton & Williams
Holly Krutka, Shenhua Group
Rich Lopriore, PSEG Fossil
Rafic Minkara, Headwaters
Ram Narula, Consultant
Bob Purgert, Energy Industries of Ohio
Mark Schoenfield, Jupiter Oxygen
Rick Smith, Ameren Energy
Ben Yamagata
Coal Utilization Research Council

Cover Photo Source:

Boon (<http://www.booninc.com/index.php>), reprinted with permission.

National Coal Council – Reliable & Resilient: The Value of Our Existing Coal Fleet

COAL POLICY COMMITTEE

Robert O. Agbede, Chester Engineers
Sy Ali, Clean Energy Consulting
Richard Bajura, West Virginia University
Theodore K. Barna, Barna Solutions, LLC
Janos M. Beer, Massachusetts Institute of Technology
Jacqueline F. Bird
F. William Brownell, Esq., Hunton & Williams
Dr. Frank Burke, Consultant
Stu Dalton, EPRI
Jack Daly, Sargent & Lundy
Ted Doheny, Joy Global, Inc.
Michael D. Durham, ADA-ES
John Dwyer
John W. Eaves, Arch Coal, Inc.
George Ellis, Pennsylvania Coal Association
Alex G. Fassbender, Ecovia Corporation
Paul J. Feldman, Midwest ISO
John S. Fischer, Breakthrough Energy, LLC
Mark Fraley, FirstEnergy Solutions Corp
Robert D. Gabbard, PPL EnergyPlus, LLC
Guy Gorney
Manoj K Guha, Energy & Environmental Services
Clark D. Harrison, CH2M Hill
William Hoback, IL Office of Coal Development
Gerald (Jerry) A. Hollinden
Clarence Joseph Hopf, PPL EnergyPlus
Marty Irwin, IN Center for Coal Tech. Research
Michael Karmis, Virginia Tech
Norman Kettenbauer, GenPower Services
Klaus Lambeck, Public Utilities Commission of Ohio
John T. Long, Connemara Ltd.
Richard P. Lopriore, PSEG Fossil LLC
Jason Makansi, Pearl Street, Inc.
John S. Mead
Nancy Mohn, ALSTOM
Ram G. Narula
Kenneth J. Nemeth, Southern States Energy Board
Jerry J. Oliver, Global Tech Management Services
Fredrick D. Palmer, Peabody Energy
Robert M. Purgert, Energy Industries of Ohio
Mark Schoenfield, Jupiter Oxygen Corporation
Gregory A. Workman, Dominion Resources

Reliable & Resilient

The Value of Our Existing Coal Fleet

Table of Contents

A. Executive Summary	1
1. Introduction.....	1
a. Flexibility and Reliable Operation	3
b. Improving Unit Efficiency	4
c. Reducing Emissions	5
i. Traditional Emission Controls	5
ii. Retrofitting CCS	6
2. Key Findings and Recommendations	7
a. The Value of the Existing Coal Generation Fleet.....	7
b. Changes that Could Impact the Existing Coal Generation Fleet.....	8
c. Improving Fleet Flexibility and Reliability.....	9
d. Increasing the Efficiency of the Existing Fleet.....	9
e. Reducing Emissions from the Existing Fleet.....	10
The 2014 Polar Vortex	12
B. The Role (Benefits) of the Existing Coal-Fired Power Plant Fleet, Including Portfolio Value	17
1. Background.....	17
2. Profile of the Existing Coal Fleet.....	18
3. Benefits Provided by the Coal Fleet	21
a. Direct and Macroeconomic Benefits.....	21
b. Supply and Price Stability Benefits	27
c. Environmental Benefits	31
d. Carbon Capture, Utilization and Storage (CCUS).....	33
4. Findings and Recommendations	35
a. Findings.....	35
b. Recommendations.....	36
C. Changes that Could Impact Future Benefits from the Existing Coal Fleet	37
1. Reduced Rate of Demand for Electricity	37

National Coal Council – Reliable & Resilient: The Value of Our Existing Coal Fleet

2.	More Advantageous Natural Gas Prices.....	39
3.	Environmental Regulation.....	41
a.	Non-CO ₂ Regulations	41
b.	CO ₂ Limitations	41
c.	Other Related Regulations	42
d.	Cumulative Impacts.....	42
4.	New Source Review – Major Modifications	42
5.	Aging of Fleet.....	45
6.	Reduced Funds for R&D (Industry & Government).....	47
7.	Findings and Recommendations	48
a.	Findings.....	48
b.	Recommendations.....	48
D.	Technology Responses to Maximize Future Benefits to Society.....	49
1.	General Introduction.....	49
2.	The Path to Improving the Flexibility & Maintaining the Reliability of the Existing Fleet	49
a.	Background and Introduction.....	49
b.	Analysis and Discussion	50
c.	Findings.....	54
d.	Recommendations.....	55
3.	Improving the Efficiency of Power Generation From the Existing Coal Fleet	56
a.	Background and Introduction.....	56
b.	Analysis and Discussion	57
i.	Fuel Type and Fuel Processing	58
ii.	Boiler and Steam Conditions.....	60
iii.	Steam Turbine and Condenser	61
iv.	Process Instrumentation and Controls	64
v.	Low Temperature Heat Recovery	64
vi.	Auxiliary Power Consumption.....	65
vii.	Cooling System	66
viii.	Changing Plant Thermodynamics	66
ix.	Cumulative Benefits of Multiple Actions	69
x.	Important Caveats.....	70
c.	Findings.....	71
d.	Recommendations.....	72

National Coal Council – Reliable & Resilient: The Value of Our Existing Coal Fleet

4. Emission Reductions from the Existing Fleet	72
a. Addressing Conventional Pollutants	72
i. Background and Introduction	72
ii. Analysis and Discussion	73
iii. Findings	75
iv. Recommendations	75
b. Retrofitting CCS on the Existing Coal Fleet.....	75
i. Background and Introduction	75
ii. Analysis and Discussion	75
iii. Findings	85
iv. Recommendations	86

APPENDIX A Turbine Upgrade or Efficiency Improvement Projects Cited in NSR Enforcement Initiative

1. Turbine Upgrade or Efficiency Improvement Projects Cited in NSR Enforcement Initiative ...	1
2. Standard Turbine Overhauls or other Turbine Projects Cited in NSR Enforcement Initiative .	2

APPENDIX B Present Technical Status of CCS

1. Introduction.....	1
2. Post-combustion Control	1
3. Oxycombustion	5

APPENDIX C 2012 Generation, Million MWH by State

APPENDIX D Reports of the National Coal Council – June 1986-May 2014.....

APPENDIX E Member Roster – 2014

APPENDIX F Dissenting Opinion

APPENDIX G References.....

Reliable & Resilient

The Value of Our Existing Coal Fleet

List of Tables

Table B.1. Electricity Price in 2013, Cents/kWh.	24
Table D.3.1. Summary of Cost, Heat Rate Payoff, and Capacity Payoff for Steam Turbine Improvement Options – For Circumstances Where a Technology is Practical.	62
Table Appendix B-1. Summary of Post-combustion CO ₂ Pilot Plant and Demonstration Projects: North America and Europe.	3
Table Appendix B-2. Post-combustion CO ₂ Controls: Experience and Lessons Learned.	4
Table Appendix B-3. Status of Oxycombustion Demonstration Tests.	7

List of Figures

Figure PV1. U.S. Electricity Generation for January & February, 2012-2014.....	13
Figure PV2. Portion of Increase in U.S. Electricity Generation, by Fuel	13
Figure PV3. Projected 2020 Energy Capacity, by Fuel.....	15
Figure B.1. Estimated U.S. Primary Energy Consumption Before 1945.	17
Figure B.2. U.S. Electricity Generation by Energy Source.	18
Figure B.3. Generation by Fuel, 2012.	19
Figure B.4. Generation Fuel Mix for all Entities.....	20
Figure B.5. Generation Fuel Mix for Cooperatives.....	20
Figure B.6. Generation Fuel Mix for Public Power Utilities. (Source: APPA).....	21
Figure B.7. Levelized Cost of Electricity.	22
Figure B.8. Value of Existing Coal Fleet: Electricity Cost Savings.	23
Figure B.9. Source of U.S. Electric Power (Data from DOE/EIA).	25
Figure B.10. Average Retail 2012 Electricity Prices, by State (Data from DOE/EIA).	25
Figure B.11. Fuel Price Volatility.	26
Figure B.12. Future Fuel Prices (Data from AEO-2014, DOE/EIA).	26

National Coal Council – Reliable & Resilient: The Value of Our Existing Coal Fleet

Figure B.13. U.S. Population Change.	27
Figure B.14. Impact of Energy on Discretionary Income.	28
Figure B.15. 30% of Global Coal is in the U.S.....	29
Figure B.16. The U.S. Coal-Fueled Electricity Supply Chain.	30
Figure B.17. Coal Use and Declining Emissions.	32
Figure B.18. Power Plant Emission Trends.	33
Figure C.1. U.S. GDP: 1947-2013.....	38
Figure C.2. Annual U.S. Electricity Generation.	38
Figure C.3. Monthly Generation from Natural Gas and Coal.....	39
Figure C.4. Henry Hub Spot Prices.	40
Figure C.5. Natural Gas Price Predictions Versus Actual Price.	40
Figure C.6. U.S. Coal-fueled Generating Capacity Additions.	45
Figure C.7. Coal Generating Capacity, by State (based on EIA-Fm860 data).	46
Figure C.8. Projected Coal Capacity in 2025 (based on EIA-Fm860 data).	46
Figure C.9. DOE RD&D Budget for Coal Use Technologies.	47
Figure D.3.1. Power Plant Efficiency.....	58
Figure D.3.2. Coal Moisture Impact on Efficiency.	60
Figure D.3.3. Condenser Fouling and Turbine Heat Rate.....	63
Figure D.3.4. Schematic of Topping Cycle for Conventional Rankine Power Station.	68
Figure D.4.1. Timeline for CCS.....	79

Reliable & Resilient

The Value of Our Existing Coal Fleet

Abbreviations

ACI – activated carbon injection
AEO2013 – Annual Energy Outlook 2013
APPA – American Public Power Association
ARI – Advanced Resources International
ARRA – American Recovery and Reinvestment Act
AUSC – Advanced Ultra-Supercritical
BACT – Best Available Control Technology
bcf – Billion Cubic Feet
Btu – British Thermal Units
CCR – Coal Combustion Residuals
CCS – Carbon Capture & Storage
CCUS – Carbon Capture Utilization & Storage
CFD – Computational Fluid Dynamics
CO₂ – Carbon Dioxide
CSAPR – Cross State Air Pollution Rule
CUCR – Coal Utilization Research Council
DOE – Department of Energy
DSI – Dry Sorbent Injection
EERE – Energy Efficiency and Renewable Energy
EERS – Energy Efficiency Resource Standards
EIA – Energy Information Administration
EOR – Enhanced Oil Recovery
EPA – Environmental Protection Agency
EPRI – Electric Power Research Institute
EU – European Union
FERC – Federal Energy Regulatory Commission
FGD – Flue Gas Desulfurization
FOAK – First-Of-A-Kind
GADS – Generating Availability Data System
GDP – Gross Domestic Product
GHG – Greenhouse Gas
GW – Gigawatt
HAPs – Hazardous Air Pollutants
HHV – Higher Heating Value
H-P – High Pressure
I&C – Instruments and Controls

National Coal Council – Reliable & Resilient: The Value of Our Existing Coal Fleet

IEA – International Energy Agency
I-P – Intermediate Pressure
IPCC – Intergovernmental Panel on Climate Change
ISO-NE – Independent System Operator – New England
kWh – Kilowatt Hour
LCOE – Levelized Cost of Electricity
LHV – Lower Heating Value
LIHEAP – Low Income Home Energy Assistance Program
LNG – Liquefied Natural Gas
L-P – Low Pressure
MATS – Mercury and Air Toxics Standards
mcf – Thousand Cubic Feet
MISI – Management Information Services, Inc.
MMBtu – Million Btu
MM&V – Monitoring, Mitigation and Verification
MW – Megawatt
MWe – Megawatt Equivalent
MWh – Megawatt Hour
NAAQS – National Ambient Air Quality Standards
NCC – National Coal Council
NCCC – National Carbon Capture Center
NERC – North American Electric Reliability Corporation
NETL – National Energy Technology Laboratory
NGCC – Natural Gas Combined Cycle
NH₃ – Ammonia
NO_x – Nitrogen Oxides
NRECA – National Rural Electric Cooperatives Association
NREL – National Renewable Energy Laboratory
NSPS – New Source Performance Standards
NSR – New Source Review
O&M – Operations and Maintenance
OMB – Office of Management and Budget
PM – Particulate Matter
PRB – Powder River Basin
RCRA – Resource Conservation and Recovery Act
R&D – Research and Development
RD&D – Research, Development and Demonstration
RGGI – Regional Greenhouse Gas Initiative
ROZ – Residual Oil Zone
RPS – Renewable Portfolio Standards
SC – Super Critical
SCR – Selective Catalytic Reduction
SNCR – Selective Non-Catalytic Reduction
SO₂ – Sulfur Dioxide

National Coal Council – Reliable & Resilient: The Value of Our Existing Coal Fleet

SO₃ – Sulfur Trioxide

tcf – Trillion Cubic Feet

TWH – Terawatt Hours

UIC – Underground Injection Control

USGS – United States Geological Survey

VSD – Variable Speed Drives

WFGD-WWT – Wet Flue Gas Desulfurization-Wastewater Treatment

Reliable & Resilient – The Value of Our Existing Coal Fleet

An Assessment of Measures to Improve Reliability and Efficiency While Reducing Emissions

A. Executive Summary

1. Introduction

The existing fleet of coal-fired power plants underpins economic prosperity in the U.S. Coal-based generation has dominated U.S. electricity supply for nearly a century. In 2013, coal again led U.S. generation, at 39%. Low cost coal keeps U.S. electricity prices below those of other free market nations. For example, in 2013 the average price of residential and industrial electricity in the U.S. was one-half to one-third the price of electricity in Germany, Denmark, Italy, Spain, the UK and France (see Table B.1). These price differentials translate into more disposable income for U.S. consumers, and a competitive edge for U.S. industry in global markets. If the existing coal fleet were replaced with the next cheapest alternative generating source, natural gas combined cycle power plants, a conservative estimate of the impact on the U.S. economy would be a 1.5% drop in Gross Domestic Product (GDP) and a loss of 2 million jobs per year. Characteristics of the existing U.S. coal fleet, and its benefits to society (including employment benefits, economic benefits, and benefits to energy security and grid reliability), are discussed in Section B of this report.

The “Polar Vortex” weather events of January and February 2014 demonstrated the contribution of the existing coal fleet, including those units currently scheduled for retirement over the next 2 to 3 years, to the reliability of the U.S. electricity grid. AEP reported that it deployed 89% of its coal units scheduled for closure, and Southern Company reported use of 75% of its coal units scheduled for closure. Use of these units enabled utilities to meet customer demand during a period when already limited natural gas resources were diverted from electricity production to meeting residential heating needs. Nationwide, over 90% of the increase in power generation in January and February 2014 (versus January and February 2013) came from the existing coal fleet.

The U.S. benefits from having a diverse portfolio of electricity sources. However, the Energy Information Administration (EIA) projects very little new coal capacity will be built in the U.S. through 2040.¹ EIA projects that coal’s share of total generation will decline from 39% in 2013 to an average of 37% for 2014-2040,² assuming current environmental regulations.ⁱ Therefore, maintaining coal’s role in this diversified portfolio will likely rest on industry’s ability to continue safe and economical operation of the existing fleet, while making the changes necessary to ensure continued environmental compliance.

ⁱ Current regulations do not include, for example, rules now under development for CO₂ limits, restrictions on cooling water intake structures, and coal combustion residuals (ash) management.

National Coal Council – Reliable & Resilient: The Value of Our Existing Coal Fleet

The existing coal fleet will face a number of serious challenges over the next few years. Some derive from the demographics of the fleet: it is getting older. The average U.S. coal-fired power plant has operated for 39 years.ⁱⁱ Older generating units are often financially and in some cases technically, less capable of accommodating large capital investments to meet new regulatory requirements and as units age their maintenance costs increase. The age of a generating unit is not a dispositive criterion in decisions related to the continued operation of that unit, but age is one of several important considerations influencing decisions regarding capital investments to meet future reliability and environmental compliance requirements.

Other challenges relate to meeting new environmental requirements as existing coal-fired power plants must cope with a range of new air pollution regulations, as well as federal requirements related to water use, wastewater treatment and solid waste management. Additional rules are being developed to limit CO₂ emissions. Thirty states now have renewable portfolio standards or other measures like energy efficiency resource standards that tend to reduce the use of and/or place additional pressures on existing coal-fired generators in the midst of more intermittent renewable generation and additional states have established “goals” rather than standards.

Still other challenges are market oriented, such as the recent lack of growth in electricity demand and strong competition from other generation sources, including natural gas based generation. These factors are felt most strongly in competition for new generating assets, but existing units are also affected. The combination of market factors and regulatory requirements will likely result in many existing coal-fired units being retired earlier than their economic lifespan, and others operating in a “cycling”ⁱⁱⁱ or “flexible” mode in future years, rather than in a traditional “base load” mode. All of these challenges will pressure existing coal-based units to operate more cost-effectively and with greater flexibility if they are to remain in service.

Past challenges to coal generation, such as the need to reduce emissions of sulfur dioxide, nitrogen oxides and mercury, were met through collaborative efforts between the public sector and the private sector to develop new technologies. The terms “Flue Gas Desulfurization”, “Selective Catalytic Reduction” and “Activated Carbon Injection” were not part of the nation’s lexicon in 1970. Today these systems, developed through industry/government collaboration, are standard equipment on new coal-fired power plants and have been widely deployed on existing units as well. Additionally, for every dollar of federal funds invested in coal RD&D, thirteen dollars of benefits accrued to the nation. Moreover, RD&D in advanced coal technologies can produce products for sale abroad, enhancing U.S. manufacturing and improving the nation’s balance of trade. The question posed by this report is: Can this be done again? More specifically, **what technological solutions can be developed by the private and/or the public sector to enhance the existing coal generation fleet’s capacity, efficiency and emissions, as well as the jobs outlook for those that operate and supply those assets?**

ⁱⁱ Capacity-weighted age, as of 2014, excluding retirements in 2013-14.

ⁱⁱⁱ For purposes of this report, the term “cycling” includes both startup transitions and operational changes from minimum to maximum capability.

National Coal Council – Reliable & Resilient: The Value of Our Existing Coal Fleet

This report considers three main categories of technologies that, if developed, would assist the existing coal fleet in meeting many of its challenges:

- Technologies enabling more flexible operation for units that will be cycling and undergoing more frequent startups and shutdowns while maintaining reliability.
- Technologies to improve the efficiency of the existing fleet. More efficient power plants tend to emit less of all pollutants, but the focus of this report is more efficient technologies that reduce emission of CO₂.
- Technologies, other than improved efficiency, that reduce emissions from coal-fueled power plants. These technologies would address traditional gaseous, liquid and solid waste streams, as well as CO₂ emissions from existing coal-fired units.

a. Flexibility and Reliable Operation

Most large existing coal-fired power plants were originally designed to run in “base load” mode. With very low costs of operation, these units ranked high in the “economic dispatch” of units available to satisfy electricity demand by residential, commercial and industrial power consumers. As noted above, changing market conditions have led to the expectation that many of these base load designed units will, in the future, be used in a cycling mode resulting in significant operational and maintenance issues. Some may operate at base load during peak demand seasons (winter and summer), and be cycled or brought off the grid during other seasons.

Exacerbating the need for more flexibility in the remaining fleet is the expected retirement of many of the older, smaller coal fired units that have provided cycling operation in the past. About 20% of the generating capacity of the existing coal fleet is expected to retire by 2020 due to market conditions and currently applicable regulations (most of this capacity will retire by 2016, when compliance with the recent Mercury and Air Toxics Standards (MATS) is required). Two-thirds of this retiring capacity is composed of units with subcritical steam cycles, less than 300 megawatt (MW) in size. Recently these smaller older units have contributed to fleet resiliency during times of high systems demand: units now scheduled for retirement were operated near full capacity. Additional regulations now under development may increase retirements of these more flexible units.

Many of today’s sophisticated emission control systems are designed to operate under relatively constant conditions and at high load factors. For example, selective catalytic reduction systems for nitrogen oxides (NOx) control require that flue gases have a minimum temperature for the catalyst to be effective. Operating at low load may not meet this criterion with currently available catalysts, monitoring and control systems. Systems for capturing sulfur dioxide (SO₂) may operate at lower thermal efficiency at partial load, and may create new, less manageable wastewater issues and coal combustion products.

Technologies to address these problems can take several forms. One is the development of improved materials, such as better alloys and metal coatings that are stronger and less sensitive to corrosion. Stronger materials allow thinner-walled components and thinner walls result in less damage from the stress of changing temperatures that accompany cycling operation.

National Coal Council – Reliable & Resilient: The Value of Our Existing Coal Fleet

Another type of technology involves improved sensors and controls. These can both automate the optimization of multiple plant operating parameters under rapidly changing load conditions, as well as help in predicting problems before a critical component fails. Improved sensors and monitors can allow operation closer to design margins and with greater reliability by detecting performance or life degradation. Improved non-destructive diagnostic systems would also aid reliability. Existing “asset management” programs need to be modified to reflect the effects of cycling on plant economics and reliability.

An additional class of potentially useful technologies would treat coal to reduce moisture or trace element content – factors that can impact unit availability and performance, particularly when a unit is designed to use coals from a variety of sources. Enabling flexible operation at a unit that uses coals from different sources will be more difficult and costly.

In general, training programs and studies using lessons learned and best practices can assist plant operators and maintenance personnel with the improved technologies and procedures that are critical to success.

b. Improving Unit Efficiency

Decisions to commit resources to energy efficiency measures generally consider a range of factors. These include the obvious positive impacts on fuel use and reduced emissions; potentially negative impacts related to new source review policy (discussed in Section C.4.); and less obvious potential effects on operational flexibility such as achieving minimum loads, higher ramp rates, increased outage durations. Increasing attention to emissions of carbon dioxide (CO₂) will provide greater impetus to improve efficiency.

A number of technical reports have considered specific measures that could potentially be applied within a coal-fired power plant. For example, coal could potentially be dried using waste heat, making the boiler more efficient. Steam turbines could potentially be refit with modern and more efficient multistage rotors. In addition, corrosion and deposition on major heat transfer components (boiler tubes and condensers) could potentially be reduced, making heat transfer in those components more efficient.

On some units, alkali materials can be injected into flue gases to reduce acidity that would otherwise present corrosion problems at low temperatures, thereby potentially allowing greater heat recovery from flue gases. Improved sensors and controls could potentially allow a plant to operate closer to conditions optimal for higher efficiency. Variable speed drives could potentially be used to make motors more efficient, particularly at lower load.

While many of the needed technologies already exist and are operating on some units, these are not a one-size-fits-all package of solutions that can be readily applied to or accommodated by the existing coal fleet. The opportunity to apply these efficiency improvements across the existing fleet will vary significantly.

In some cases, the opportunity will be negligible because the unit either is already operating in a highly efficient mode with some or all of the improvements in place or because the implementation of potential improvements is not cost-effective and/or technically feasible. As such, the degree of efficiency improvement possible at a given unit is highly site-specific, and may depend on the design of the unit, current maintenance procedures, whether the unit operates as

National Coal Council – Reliable & Resilient: The Value of Our Existing Coal Fleet

base load or cycling, the type of coal used by the unit, system economics and the economics of the specific measure and the configuration of the unit. Even the location of a unit is relevant to efficiency because plant efficiency is sensitive to ambient temperature and atmospheric pressure (elevation).

This report does not provide a quantitative assessment of the degree to which these existing technologies could improve the heat rate (or efficiency) of the existing coal fleet. The U.S. Environmental Protection Agency (EPA), in a technical support document developed for the greenhouse gas emission rulemaking, concluded that heat rate reductions of 2-5% are possible for individual generating units, but that conclusion was not rigorously reviewed or corroborated by this report.³

Most waste heat recovery applications hinge on reliable heat exchangers which have not been adequately demonstrated in the U.S., thus there is much skepticism surrounding their viability. However, many designs have been employed abroad with reasonable success. Therefore, the public and private sectors should engage in research opportunities to adequately demonstrate and improve current designs.

It may be possible to add “topping” or “bottoming” cycles to existing units to increase their efficiency. This would involve adding one or several new components, and integrating these with the existing plant’s operation. The retrofit of a topping or bottoming step to a conventional Rankine cycle is a potential efficiency improvement that requires an extensive research, development and demonstration (RD&D) effort.

The New Source Review (NSR) permitting program unintentionally limits investments in efficiency. Some actions to improve efficiency at an existing power plant could lead to a designation of the change as a “major modification” subjecting the unit to NSR permitting requirements. These requirements usually entail additional environmental expenditures (that can reduce efficiency), as well as delays associated with processing the permit. In general, if a plant owner expects that an efficiency improvement would lead to such a designation, the efficiency project will not be pursued as the resulting permitting process would be extensive and the compliance requirements would be onerous and likely too stringent to be practicable. Unfortunately, this prospect has all but eliminated RD&D that would more than marginally innovate the fleet.

c. Reducing Emissions

In addition to the discussion on efficiency, which tends to reduce all emissions, this report considers two other categories of emission reductions at existing coal-fueled power plants: traditional emission controls and reduction of CO₂ emissions through use of carbon capture and storage (CCS).

i. Traditional Emission Controls

The existing coal fleet is generally well equipped with systems designed to control emissions of particulate matter, nitrogen oxides and sulfur dioxide. These systems and recent additions aimed at hazardous air pollutants (HAPs) are effective at removing other pollutants such as mercury. Existing units also comply with regulations related to thermal emissions to bodies of water that supply cooling water at the power plant, wastewater emissions and solid waste management.

National Coal Council – Reliable & Resilient: The Value of Our Existing Coal Fleet

However, recently proposed or adopted regulations will lead to more stringent emission reduction requirements, and often reduction of emissions in one media (e.g., air) will result in new pollution control issues in another media (e.g., wastewater). With these new rules in mind, this report recommends several areas in which collaborative RD&D could develop improved technologies to mitigate emissions. Such collaborative efforts have been highly successful in developing and commercializing technologies in the past, including flue gas desulfurization, low-NOx burner systems, selective catalytic reduction of NOx and mercury control technologies. Moreover, for every dollar of federal funding in coal technology development, approximately thirteen dollars of benefits accrued to the nation.⁴

ii. Retrofitting CCS

The Obama administration's stated long term climate goal is to reduce U.S. greenhouse gas (GHG) emissions by 83% (relative to 2005 emissions) by 2050.⁵ Although U.S. coal-fueled power plants contributed only 3% of global GHG emissions in 2012, fossil energy-based electricity generation contributed 31% of total U.S. GHG emissions in 2012 (23% from coal-fired units; 8% from natural gas-fired units).⁶ These numbers suggest any future reduction requirements will target a large reduction in CO₂ emissions from fossil energy-based power. One possible pathway for such a reduction is the development and deployment of CCS technologies. Much progress on developing CCS systems for coal-fired power plants has been achieved by the collaborative RD&D program managed by the U.S. Department of Energy (DOE). However, as indicated in DOE's program plans for CCS, much remains to be done.

Previous NCC reports have addressed CCS control technology and identified the primary shortcomings of CCS technologies currently under development to be:

- They have not been demonstrated at commercial scale on a power plant
- The knowledge base on saline storage and enhanced oil recovery (EOR) remains limited, and there are unresolved non-technical barriers to both
- The current technologies are too costly, impose significant energy penalties and can significantly increase cooling water requirements for the generating unit
- There are numerous challenges related to the integration of CCS on existing units
- Significant uncertainty exists regarding the characteristics, feasibility and availability of geologic storage opportunities
- Significant legal and regulatory challenges remain to be resolved, including those related to the long-term stewardship and liability of geologically stored CO₂

Some of these problems are being addressed to some extent by ongoing RD&D. With adequate funding, DOE plans to have 2nd Generation CCS technologies (at lower cost than current technologies) available to begin demonstration in 2020-2025, and available for commercial use a few years later. However, retrofitting existing units (or repowering them with CCS systems) poses the additional problem that there is a limited time window for development of needed technologies. **Less than 10% of the existing coal fleet will be under 40 years of age in 2030.**

As discussed in Section B, the age profile of existing coal-fired power plants varies by region, and by type of utility. For example, coal units owned by rural cooperatives tend to be newer than those operated by investor-owned utilities. Decisions on whether to retrofit capital intensive

National Coal Council – Reliable & Resilient: The Value of Our Existing Coal Fleet

hardware, such as CCS systems, are based on multiple economic factors, some of which relate to the remaining useful life of potential retrofit candidates, and some of which are highly uncertain when projected 15 years into the future. These uncertainties include the capital cost of competing electricity generation technologies, new environmental requirements and the future price of natural gas. Nevertheless, from both an economic perspective and from the perspective of meeting climate change mitigation goals, much less costly CCS technologies are needed much sooner than the current program provides.

In addition, although DOE has a robust research and development (R&D) program, there does not appear to be a plan to obtain the resources needed to move research products to the more costly demonstration stage of technology development.

2. Key Findings and Recommendations

The following key findings and recommendations are taken from the more detailed listings of findings and recommendations in Sections B, C and D.

a. The Value of the Existing Coal Generation Fleet

Findings

- The U.S. existing coal fleet continues to play a vital role in meeting our nation’s electric power needs. The extreme cold weather events of the winter of 2013-2014 highlight the need to maintain a diverse portfolio of generation options in order to ensure the availability of affordable, reliable power for residential and industrial uses.
- The historical deployment of advanced coal technologies demonstrates that coal generation can be increased while simultaneously reducing emissions.
- Retrofitting advanced environmental technologies and enhancing efficiency at existing coal plants could result in the creation of 44,000 to 110,000 jobs, depending on the degree of efficiency improvement achieved.

Recommendations

- DOE should lead collaborative efforts with industry to assess the impacts of the 2014 polar vortex experience on power prices, availability and reliability.
- DOE should ensure that basic federal energy policy assessments, such as the Quadrennial Energy Review⁷ and the President’s Advanced Manufacturing Initiatives⁸ consider the impact of lower priced electricity facilitated by coal-fired power plants, and include an assessment of the value of diversity of generation sources and how pending coal plant retirements are likely to impact power prices, availability and reliability.
- DOE should lead collaborative efforts with industry to evaluate the implications of generation diversity on the President’s advanced manufacturing initiatives and efforts to enhance the global competitiveness of U.S. manufacturers.

National Coal Council – Reliable & Resilient: The Value of Our Existing Coal Fleet

b. Changes that Could Impact the Existing Coal Generation Fleet

Findings

- Natural gas prices continue to be volatile, reinforcing an historical trend. Past efforts by both industry and government have not produced accurate predictions of future natural gas prices. Increased reliance on natural gas for power generation will impact price stability and resource supply.
- The price of coal per unit of energy delivered to electric power plants is less than the price of delivered natural gas. EIA projects that coal's price advantage will increase through at least 2040.
- New Source Review regulations impact generators' decisions and ability to enhance plant efficiency, reduce emissions and improve overall operations/capacity. The delay and cost associated with obtaining an NSR permit tend to eliminate efficiency enhancement projects as viable options.
- Many of the challenges facing the existing coal fleet are technology based, and would benefit from DOE-led collaborative RD&D with industry. Funding requirements, particularly for demonstration projects are significant.
- EIA projects that 60 gigawatts (GW) of coal capacity will be retired by 2020, relative to 2010, based on projected market conditions, but not considering a series of recently proposed and not yet promulgated environmental regulations applicable to coal-fired power plants.
- Notwithstanding retirement of approximately 20% of the coal fleet capacity, EIA projects that under current regulations, coal-fired generation will remain approximately the same from 2010 through 2040.

Recommendations

- DOE should work with the EPA to eliminate New Source Review-related barriers that disincentivize generators to pursue efficiency improvements that would otherwise reduce emissions, increase capacity and enhance plant operations.
- DOE should seek input from industry research associations such as the Electric Power Research Institute (EPRI) and Coal Utilization Research Council (CURC), regarding priority research needs and the appropriate balance between research, development and demonstration of technologies relevant to the existing coal fleet.

National Coal Council – Reliable & Resilient: The Value of Our Existing Coal Fleet

c. Improving Fleet Flexibility and Reliability

Findings

- In the future, factors such as increased deployment of intermittent renewable energy technologies, competition from other fossil fueled generation, use of non-design coals and the increasing age of the coal generation fleet will lead to increased operation of base load-designed coal generation units in a cycling mode.
- Greater understanding of failure mechanisms leading to tube leaks, component failures and other malfunctions leading to forced outages and reduced equipment life are necessary to maintain system reliability.
- Similarly, major emission control subsystems were generally designed for steady state operation and may not operate as reliably or effectively under changing load conditions.

Recommendations

- DOE should lead collaborative RD&D efforts with industry to develop assessment tools, improved sensors and controls, non-destructive evaluation, remaining life evaluation and an understanding of damage mechanisms.
- DOE should lead collaborative RD&D efforts with industry to enhance practical knowledge about operating flue gas desulfurization (FGD) and selective catalytic reduction (SCR) systems in a cycling environment, with a range of off-specification coals.
- DOE should lead collaborative RD&D efforts with industry to develop advanced materials that are more corrosion resistant and have increased strength. Stronger heat exchanger materials can be designed with thinner walls that are more tolerant of temperature cycling.

d. Increasing the Efficiency of the Existing Fleet

Findings

- Modest improvements in efficiency are possible at some units with existing technologies to improve heat transfer, reduce heat losses and make better use of low quality heat.
- New Source Review policy is a major barrier to implementing known efficiency measures at existing coal-fueled power plants.
- The addition of a topping or bottoming cycle to an existing generating unit's Rankine cycle, if proven feasible and developed commercially, could deliver significant efficiency improvements. Practical systems could require up to 10 years to commercialize.

Recommendations

- DOE should lead collaborative RD&D efforts with industry to develop topping and bottoming cycles that can be retrofit to existing power plants.
- DOE should work with regulatory agencies to remove NSR barriers to efficiency upgrades.
- DOE should lead collaborative RD&D efforts with industry to develop best practices manuals for potential application of currently known techniques to improve power plant efficiency.

National Coal Council – Reliable & Resilient: The Value of Our Existing Coal Fleet

e. Reducing Emissions from the Existing Fleet

Findings

- Past federal RD&D to improve the performance and reduce emissions from coal-fired power plants has yielded \$13 of benefits for every dollar of federal investment.
- Proposed standards for wastewater effluents from existing coal-fueled power plants are not achievable under all operating conditions (e.g., for wastewaters with high oxidation reduction potential) using existing technologies.
- Some of the challenges posed by emerging regulations for traditional pollutants are the result of other emission control systems. For example, bromine or other chemicals introduced to enhance mercury removal from flue gases can alter wastewater streams from air pollution control devices.
- The recently proposed CO₂ New Source Performance Standards (NSPS) rules specified more stringent monitoring and reporting requirements for power plant CO₂ used for EOR versus “natural” CO₂ used for EOR. According to a major EOR operator, “the proposed NSPS rule will foreclose – not encourage – the use of CO₂ captured by emissions sources in EOR operations.”⁹ It is unclear whether these rules, when finalized, will allow the flexibility needed by EOR operators in practical EOR projects.
- Substantial progress has been made on CCS systems for CO₂ capture from power plants, but much more work is needed before these systems can be a practical commercial option for existing power plants. Cost, system integration and legal framework issues are all major barriers to deployment of currently available technologies.
- While many of the more technical aspects and costs of the CCS process are fairly well categorized, the costs and risks associated with monitoring, mitigation and verification (MM&V), permitting, site negotiation, property rights, liability, legal/contracting costs, costs of meeting legal or regulatory requirements, etc., are less well understood and quantified.

National Coal Council – Reliable & Resilient: The Value of Our Existing Coal Fleet

Recommendations

- DOE should lead collaborative RD&D efforts with industry to develop:
 - technologies and mechanisms to meet additional requirements for wastewater effluents from existing coal-fueled power plants,
 - technologies to address control of secondary emissions from primary emission control systems, such as bromine and trace metals removed from flue gases that are discharged via wastewater streams, and
 - systems to conserve water and reduce cooling water environmental impacts from existing power plants.
- The need for accelerated solutions points to greater emphasis on hands-on test facilities that emulate the National Carbon Capture Center design concept.
- DOE should place much more emphasis on commercial scale demonstration of CCS systems, both capture and storage options.
- DOE should work with states and regulatory agencies to create a pragmatic legal framework for CO₂ storage, particularly in saline formations, and to avoid monitoring requirements that deter use of captured CO₂ in EOR applications.
- DOE should lead collaborative RD&D efforts with industry to analyze CO₂ storage related issues associated with meeting financial responsibility compliance per Class VI Underground Injection Control (UIC) regulations [40 CFR §146.85].

The 2014 Polar Vortex

The National Coal Council’s Existing Coal Fleet Study was conducted during the winter of 2013-2014. The severe cold weather events experienced throughout the U.S. highlighted the value of our existing coal fleet and reinforced the need to maintain our coal generation option.

In January and February of 2014, the nation was swept with a series of cold weather events that tested the integrity of electricity supply. In general, electricity supply met demand, even under these severe conditions. However, electricity and gas prices surged for many consumers as energy supplies were stretched to their limits. More importantly, with increasing levels of coal retirements scheduled over the next three years (five times the level of retirements in 2012), it is clear that if those retirements had already occurred, the outcome this winter would have been much worse.

“This country did not just dodge a bullet – we dodged a cannonball.”
– Nick Akins, CEO
American Electric Power
Testimony before
Senate ENR Committee

During increased power demand for much of the U.S. in January, for example, alternative fuels were significantly supply constrained and in the words of *The New York Times*, “Coal [came] to the Rescue.”¹⁰ Wind produced only 4.7% of the nation’s power while solar produced less than 0.2%. Nuclear provided only 5% of incremental “year-over-year” generation and hydroelectric output *declined* 13%. As natural gas supplies faltered, gas turbines were taken offline but gas prices still spiked from the Northeast through the South to the Midwest to the Northwest. In some areas gas to produce electricity was more expensive than liquid fuel, even though the price of oil for generation rose to over \$400 per barrel. Public Service of New Hampshire resorted to burning jet fuel and for the U.S. as whole, oil accounted for more incremental year-over-year generation than did nuclear power.

To some degree, the events of the 2013-2014 winter and their causes were predicted. The Federal Energy Regulatory Commission’s (FERC) Winter Reliability Assessment, published in December 2013 stated: *“The 2012–2013 winter period demonstrated that New England’s natural gas dependency risk continues to escalate and existing fuel arrangements of many generators will lead to continued challenging and complex operating conditions when the power system and fuel supply deliveries are stressed.”*¹¹

As shown in Figure PV1, for the months of January and February 2014, compared to the same months in 2013 and 2012, coal was the leading source of electric power in the U.S. Figure PV2 shows that, for the winter of 2014, compared to 2013, coal-fueled generation provided 92% of that increase.¹² Although demand for power was greater in 2014, generation by natural gas decreased, because natural gas was diverted to fuel residential heating needs and gas prices soared to over three times that of coal.¹³ As the year progresses, the nation is depending upon “gas to coal switching” to refill gas storage, which declined to 822 billion cubic feet (bcf) at the end of March 2014, the lowest level in over a decade and almost one trillion cubic feet lower than April 2013.¹⁴ A record average of at least 90 bcf/week of injections would be required over the

National Coal Council – Reliable & Resilient: The Value of Our Existing Coal Fleet

next seven months to refill storage to 3.5 trillion cubic feet (Tcf). The average injection in 2013 was ~ 64 bcf/week.

Figure PV1. U.S. Electricity Generation for January & February, 2012-2014

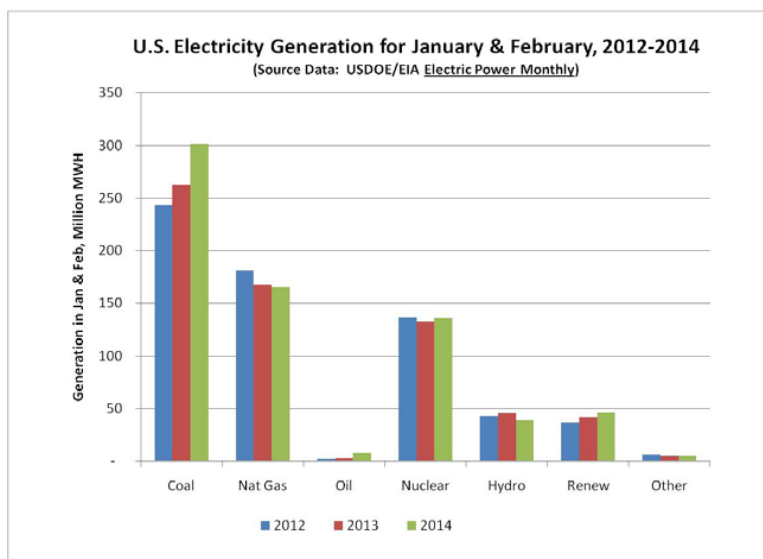
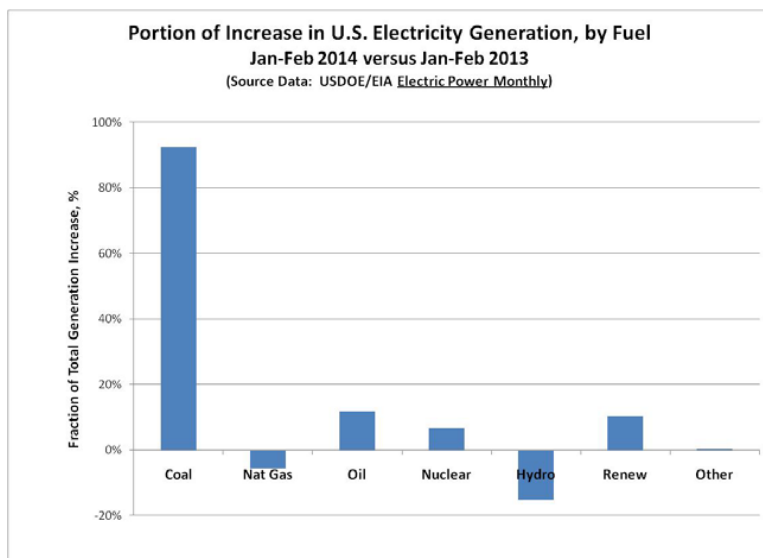

Figure PV2. Portion of Increase in U.S. Electricity Generation, by Fuel



The U.S. may or may not reach adequate storage by the beginning of this year’s winter heating season, but one fact is certain: without the ability to shift generation from gas to coal, the goal would be impossible, and with another round of severe weather the U.S. would see another and far more severe shortfall in gas supply accompanied by rising prices. More than an additional 500

National Coal Council – Reliable & Resilient: The Value of Our Existing Coal Fleet

bcf in gas to coal switching is required in 2014 to reach average storage. In short, without gas to coal switching over 2013-2014, storage would now be virtually exhausted or, far more likely, prices would be at record levels.

The U.S. coal fleet's value has never been more apparent. Yet, a significant portion of the electricity required to make up for the limitations of gas and other fuels is provided by coal plants slated for closure, many of which are prematurely being taken off the grid because of increasingly stringent regulatory policies. Plants such as Brayton Point (1,530 MW) in Massachusetts enabled many states to avoid a full blown energy crisis.

- "89% of our coal capacity slated for retirement in mid-2015 is called upon and running. Natural gas delivery is challenged." Nick Akins, CEO, American Electric Power
- At one point about 75% of New England's gas generating capacity was not operating due to lack of supply or high prices.
- At least 75% of Southern Company's coal power plants scheduled to soon close was needed to meet consumer demand.
- The Tennessee Valley Authority set new records for electricity demand at the same time that many of its coal-fired generating facilities are scheduled for closure, including two of its three highly productive Paradise Units.
- "We really counted on [a] combination of coal and gas and nuclear and pump storage and hydro, we needed every bit of it." Lynn Good, CEO, Duke Energy
- The North American Electric Reliability Corporation (NERC) found that the New England generation fleet is overly reliant on natural gas as a primary fuel source, and generators are heavily dependent on pipeline capacity released by the firm capacity rights holders.¹⁵
- Public utility commissions in Ohio and Pennsylvania urged consumers to conserve, especially electricity. "I have been on the commission since 2008. This is the first time we have had to issue a winter conservation request." Pennsylvania PUC Chairman Robert Powelson

The value of the existing coal fleet is not an abstract concept. At a time of great stress on power demand in Jan/Feb 2014, coal produced 92% of the increase in U.S. electricity generation, relative to Jan/Feb 2013.

Without the coal plants slated to go offline, these regions as well as others would not have met the demand for power. The capacity factor of America's coal plants averages almost 70% while many gas plants could not get fuel this winter and will continue to be replaced by coal throughout the year. What will happen when these reliable base load coal plants are closed in the next 24 months? Importantly, once a coal unit is closed, its license terminates.

Based on the most recent data from EIA, if premature closures proceed, by 2018 natural gas generating capacity will exceed that of coal, nuclear and hydro combined. (See Figure PV3.) With the closure of at least 60 GW of coal generation capacity in the next few years, America will be excessively dependent on gas for electricity. Gas prices are more volatile than any other fuel;

National Coal Council – Reliable & Resilient: The Value of Our Existing Coal Fleet

sustained supply has yet to be demonstrated and is questionable due to the rapid decline rate of shale gas production from newly completed wells.

Figure PV3. Projected 2020 Energy Capacity, by Fuel.

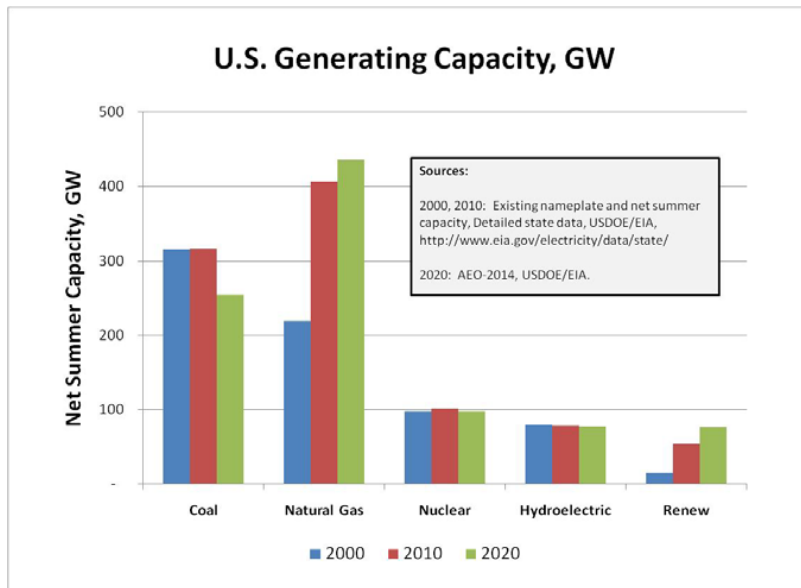

**"Even in the last year, you've seen nearly a 50 percent increase in the price of natural gas from where it was in 2012. There's a storm that's brewing."
Randall Data, CEO, Babcock and Wilcox, 2014**

Energy price spikes and supply problems in New England and throughout the nation this winter demonstrated that current coal policies are imprudently placing the reliability, affordability and security of America's electric supply system at risk. The problems in New England are precursors to other parts of the nation where overdependence on gas prevails and is even further on the rise. New England and New York City spot natural gas prices have averaged \$19.81/million Btu (MMBtu) through March compared with \$18.25/MMBtu for fuel oil that can be used in power generation.

Reliability and affordability are both at risk. Gordon van Welie, CEO of the New England Independent System Operator (ISO-NE) has warned: "The region abruptly went from a capacity surplus and low prices to a capacity shortfall and relatively high prices." The capacity shortfall will cost New England utilities over \$3 billion by 2018. The recent average price for a megawatt hour of electricity in New England was \$163 – that is 200% higher than in January 2013 and 400% higher than in January 2012, and the outlook for 2015 and beyond is bleak.

"As demonstrated by cold snaps just this winter, natural gas prices are volatile and spike...This has an immediate adverse effect on consumer electric bills. Coal, and its stable price is a long-term proven hedge against natural gas volatility and is critical if we are to continue to provide affordable electricity for our members." John Novak, Director of Environmental Issues, National Rural Electric Cooperative Association

Warnings over the impacts from loss of coal capacity have been sounded by industry over the past few years. The planned near term closings of two major coal plants (Brayton Point, 1530

National Coal Council – Reliable & Resilient: The Value of Our Existing Coal Fleet

MW and Salem Harbor, 750 MW) and one nuclear station (Vermont Yankee, 600 MW), essentially ignores warnings from agencies focused on reliability, including NERC and FERC. And, closure will apparently proceed despite the NE-ISO declaring Brayton as a “must-run” facility.¹⁶ Worse is to come, as New England digs its hole deeper: It is planning to rely on natural gas and (non-hydro) renewable energy for about 80% of its electricity.^{17,18}

Other states face similar risks, such as Florida, Delaware, Massachusetts, Nevada and Rhode Island, all of which used natural gas to generate over 60% of the electrical generation in 2013.¹⁹ In fact, most of the southern tier is at increasing risk as overdependence on natural gas proliferates. Over 130 million people now rely on natural gas to provide more than 50% of their electricity in summer and the number is steadily increasing. EPA rules may force Arizona to close Navaho Generating Station, a facility associated with a large Native American workforce and the source of more than one-seventh of the state's electricity.

Based on EPA policies Ohio would lose at least 40 coal generating units, Pennsylvania 26, Alabama 21 and Wisconsin 14.²⁰ With over 300 units closing, few states will be untouched by the consequences of the loss of reliable and affordable coal-based electricity. Gas price spikes have nationwide consequences, cost jobs and overwhelm family budgets, pushing more and more households to seek government aid to pay electric bills and heat their homes.

Summary Implications of Projected Retirements

EIA indicates at least 54 GW of coal generation will be forced to close by 2016, more than one-sixth of the entire coal fleet in just two years. At over 1,600 terawatt hours (TWH) of output, coal produces about 40% of the nation's electricity^{iv} and the cuts into reliable coal capacity may go much deeper, particularly as environmental regulations now under development are promulgated. Units that retired in 2010-2012 were relatively small, with an average size of 97 MW and heat rate of 10,695 British Thermal Units/kilowatt hour (Btu/ kWh). In contrast, units currently scheduled for retirement are larger and more efficient; at 145 MW, the average size is 50% larger than earlier retirements, with an average heat rate of 10,398 Btu/kWh.

The major “lesson learned” from the Polar Vortex experiences in January and February of 2014 was that the U.S. power grid is less resilient than previously believed. Only the availability and operation of coal units now scheduled for retirement over the next two years enabled the power sector to meet demand during periods of harsh weather events.

^{iv} The EIA [Annual Energy Outlook – 2014](#) projects that, based on current regulations, coal's contribution to total generation will average 37% for the period 2014-2040.

B. The Role (Benefits) of the Existing Coal-Fired Power Plant Fleet, Including Portfolio Value

1. Background

The U.S. relied on wood as its primary source of energy during its first century. However, coal offered the opportunity to exploit entirely new ranges of industrial activity, including steel production, Portland cement and glass production, and chemicals derived from gasified coal.²¹ After the Civil War, and until the end of the Second World War, coal provided the bulk of energy in the U.S. The 1882 opening of Thomas Edison’s Pearl Street Station in Manhattan launched a new energy age. Coal-generated steam drove six dynamos that supplied electricity through 20 miles of underground cable to light one square mile of New York City. And Edison’s incandescent light bulb replaced the intense electric arc systems in earlier electric lighting applications.²² In a rush of technological advances, alternating current systems replaced direct current systems (making longer range transmission practical), steam turbines replaced reciprocating designs and electric motors and electric appliances expanded markets beyond lighting applications. By 1929, two-thirds of American homes had electricity.²³ Figure B.1 shows U.S. energy consumption by fuel for the period up to 1945.²⁴ Today, electricity is integral to almost all aspects of everyday life in the U.S. – including work, play, health care, safety and communications. Electricity continues to increase in importance in the U.S. economy, increasing from 38% of total U.S. energy consumption in 2000 to 42% forecast in 2040.^{25, 26}

Figure B.1. Estimated U.S. Primary Energy Consumption Before 1945.

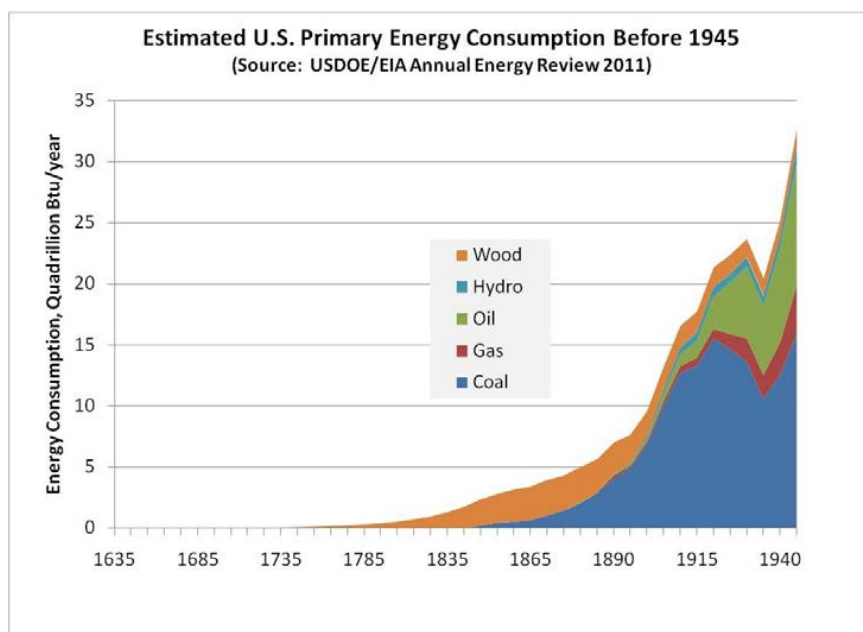

National Coal Council – Reliable & Resilient: The Value of Our Existing Coal Fleet

The U.S. National Academy of Engineering ranked electrification as the “most significant engineering achievement of the 20th Century.”²⁷ Similarly, in November 2013 the *Atlantic* magazine assembled a panel of scientists, engineers, entrepreneurs and technologists to assess the 50 innovations “that have done the most to shape the nature of modern life since the widespread use of the wheel.”²⁸ Electricity was ranked the second most significant, after the printing press.

2. Profile of the Existing Coal Fleet

Figure B.2 shows the growth of U.S. electricity generation from 1950–2013, by energy source.²⁹ Throughout this period, coal has dominated electricity generation, typically providing about half of total U.S. generation.³⁰ This dominance has resulted from coal’s domestic abundance, accessibility, reliability and low cost compared to other generation alternatives.

Figure B.2. U.S. Electricity Generation by Energy Source.

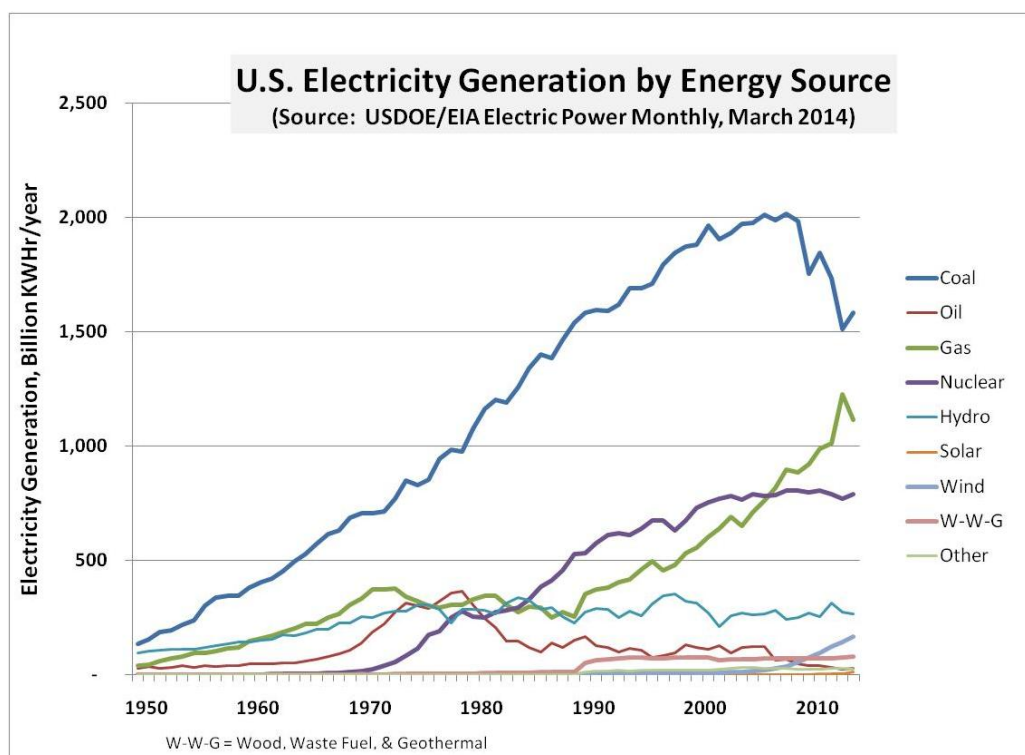

States vary considerably in their reliance on a particular fuel for electricity generation. Figure B.3 presents generation data by fuel for the year 2012.³¹

The Clean Air Act Amendments of 1970, and additional amendments in 1977 and 1990, have led to regulations limiting emissions of multiple air pollutants from coal-fired power plants. By the end of 2011, 60% of the U.S. coal fleet had FGD scrubbers installed (for SO₂ control), and 67% had either a SCR or a selective non-catalytic reduction (SNCR) installed (for NO_x control).³² Remaining units generally reduced SO₂ emissions through the use of low sulfur coal, and NO_x

National Coal Council – Reliable & Resilient: The Value of Our Existing Coal Fleet

emissions through the use of low-NOx combustion modifications. EPA projected that the MATS would result in additional deployment of air pollution control equipment, including another 22 GW of dry FGD, 43 GW of dry sorbent injection (DSI), 141 GW of activated carbon injection (ACI), 101 GW of fabric filters, 34 GW of electrostatic precipitator upgrades and 63 GW of FGD upgrades.³³

Figure B.3. Generation by Fuel, 2012.^v

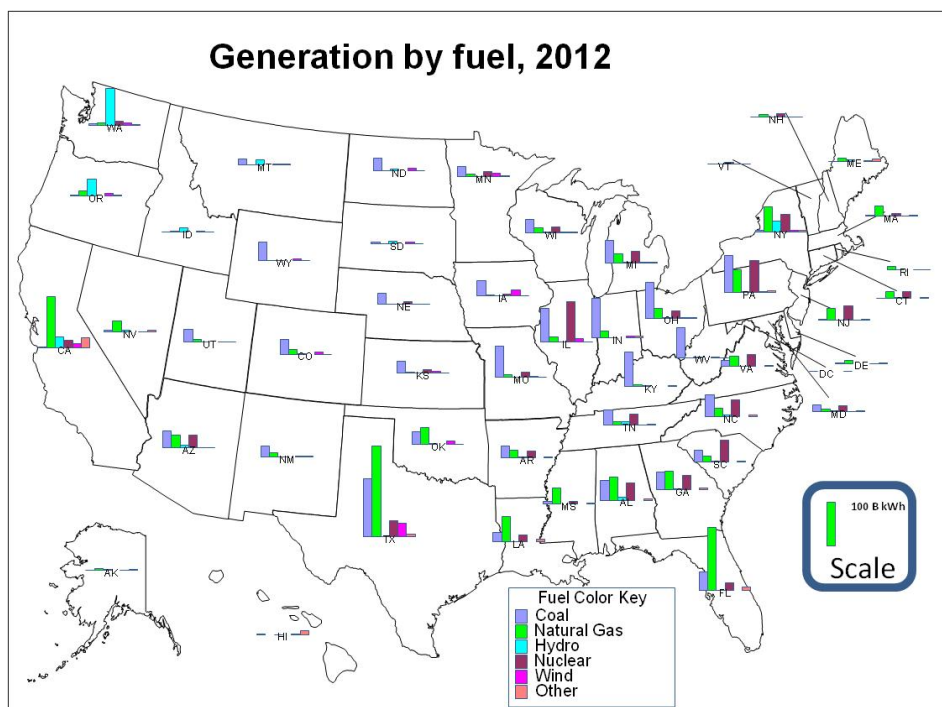

Just as there is substantial variability the mix of power generation sources geographically, the mix also varies by business structure. Investor owned utilities and non-utility generators dominate generation, with each providing 39% of total U.S. generation in 2011. However, publicly owned utilities (state and municipally owned power entities) contributed 10% of total generation, federal power agencies contributed 7%, and cooperatives contributed 5%.³⁴

Figure B.4 shows the contribution by fuel type for all power generation in 2012, and Figure B.5 shows the contrast for rural cooperatives.³⁵ Note the much larger reliance by cooperatives on coal, and correspondingly less reliance on natural gas. The fuel mix for public power utilities (for 2011) is similar to that for cooperatives, with 45% of generation from coal, and 16% from natural gas.³⁶ The business structure is relevant to technology choices because different types of entities have different sensitivities to capital investment due to financial structures and taxation. For

^v Based on EIA data. A state tabulation of generation and electricity price data is included as Appendix 3.

National Coal Council – Reliable & Resilient: The Value of Our Existing Coal Fleet

example, investor owned utilities typically finance power plants with approximately 50% debt and 50% equity, whereas publicly owned utilities finance almost entirely via debt instruments, and interest on municipal bonds is not subject to federal income tax.

Figure B.4. Generation Fuel Mix for all Entities.

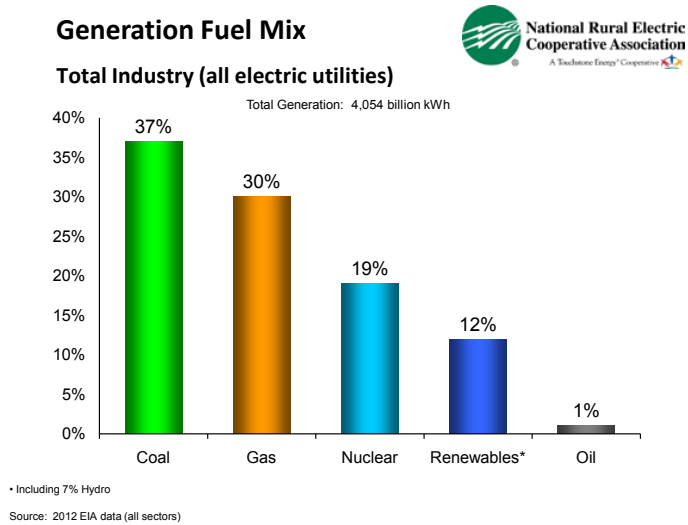
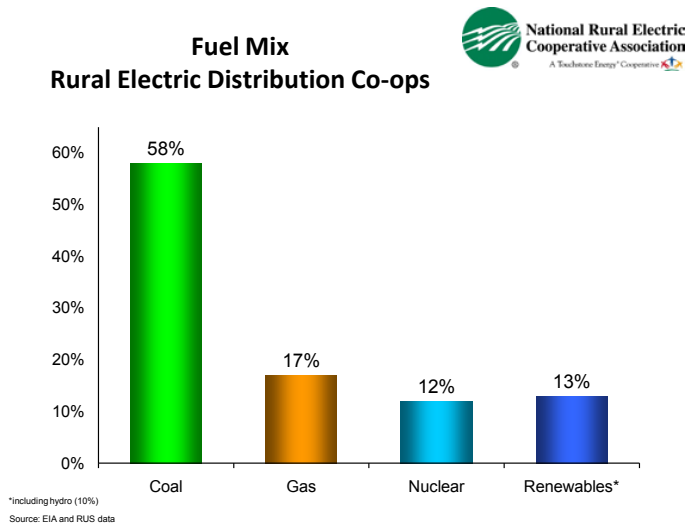
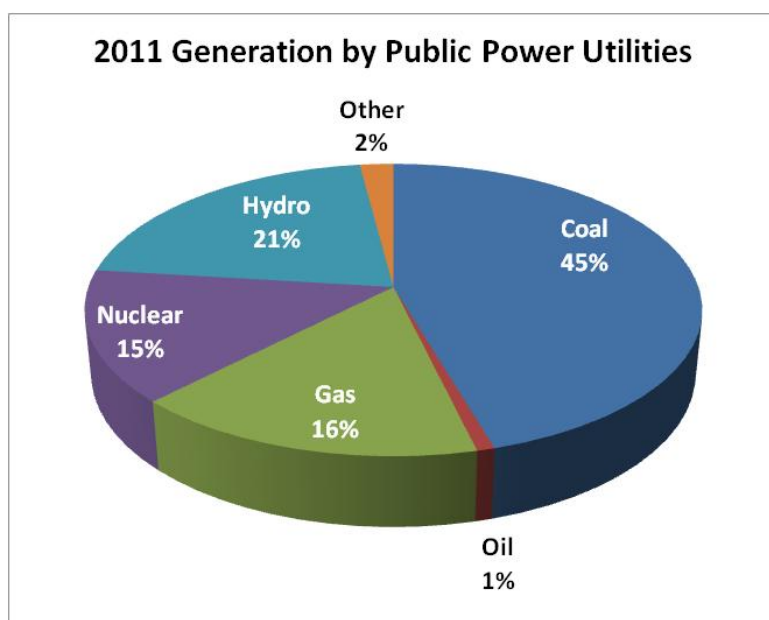

Figure B.5. Generation Fuel Mix for Cooperatives.



National Coal Council – Reliable & Resilient: The Value of Our Existing Coal Fleet

Figure B.6. Generation Fuel Mix for Public Power Utilities. (Source: APPA)



3. Benefits Provided by the Coal Fleet

The current coal fleet (approximately 310 GW of generating capacity) is the result of decades of bipartisan support of coal, ranging from Presidents John Kennedy to Jimmy Carter to Ronald Reagan to George Bush. In 1980, Carter asked Congress to mandate that “utility companies cut their massive use of oil by 50% within the next decade and switch to other fuels, especially coal, our most abundant energy source.” From the Democratic 1980 Platform: “The Democratic Party regards coal as our nation's greatest energy resource. It must play a decisive role in America's energy future. We must increase our use of coal.” Since 1980, coal generation has increased 37% or 425 TWH – more than the current total power production of the United Kingdom. The existing fleet of coal-fired power plants underpins economic prosperity in the U.S. Coal-based generation has dominated the U.S. electricity supply for nearly a century. (See Figure B.2.)

The benefits derived from the existing coal fleet have several components. These include the direct and macroeconomic benefit of low-cost electricity, the portfolio value of having a diverse mix of fuels and technologies for power generation, and the energy security value of a power generation option that is not dependent upon real-time fuel delivery/transport and is relatively immune to purposeful attack (terrorism).

a. Direct and Macroeconomic Benefits

Macroeconomic benefits can be estimated by calculating the cost of replacing generation from coal with the most economical source of new generation.

Figure B.7 shows the levelized cost of electricity (LCOE) in megawatt hours (MWh) for a range of types of new power plants, based on cost parameters used by DOE/EIA in its Annual Energy

National Coal Council – Reliable & Resilient: The Value of Our Existing Coal Fleet

Outlook, including fuel costs projected for 2018-2048. Note that for these assumptions, the least costly form of new electric power is a natural gas combined cycle (NGCC) unit, without a system to capture and store CO₂ (\$67/MWh, in 2011 \$s). Note also that the non-capital (operating) costs for a well-controlled coal unit total about \$35/MWh.

One way of estimating the value of the existing coal fleet is to calculate the cost of replacing it with another form of generation. If it were even possible to replace the existing coal fleet with the least cost source of new electric power, then the operating costs of the coal fleet (\$35/MWh) would be replaced by full levelized costs for new NGCC generation. Under EIA’s “Reference Case”, that price would be \$67/MWh. However, with the substantial increase in gas consumption caused by replacing so much coal generation, gas prices would increase above the amount assumed in the EIA reference case. For this analysis, the future price of gas was postulated to equal EIA’s “Low Oil & Gas Resource Case,” resulting in a higher gas price, and a resulting LCOE of \$72/kWh. Even this price is considered conservative since the additional NGCC units would require over 11 quadrillion Btu of gas per year, 48% of the total domestic dry gas production in 2011.

Figure B.7. Levelized Cost of Electricity.

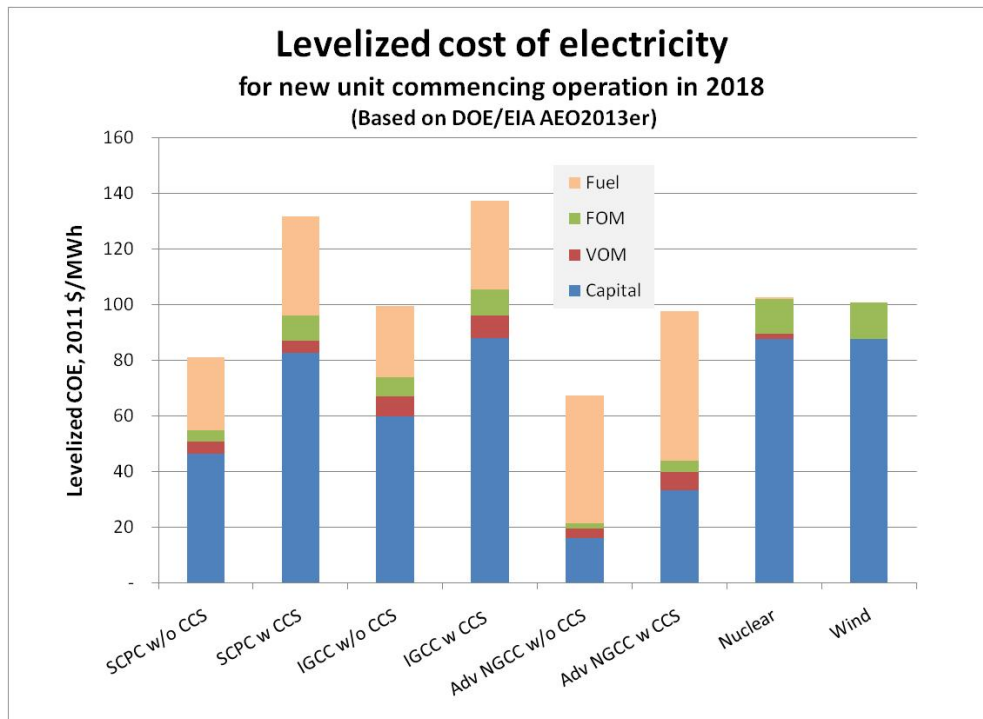
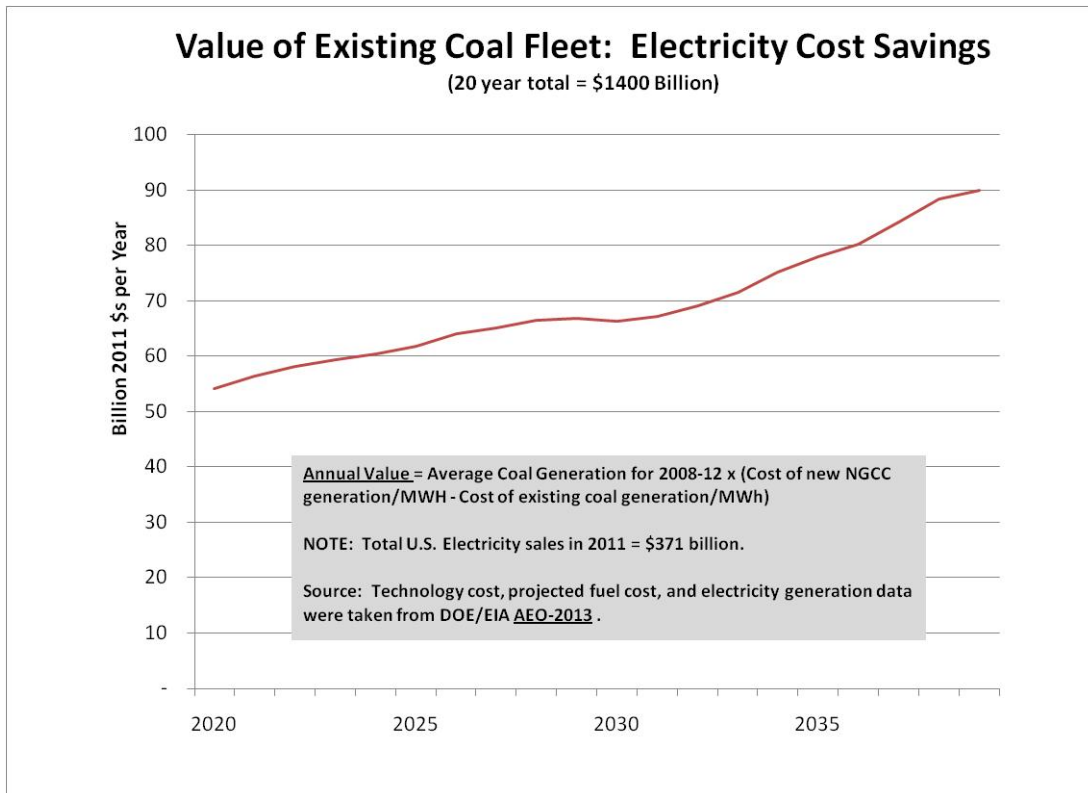

Figure B.8 shows the implications of such a replacement program, assuming EIA projected fuel costs for each year, the average generation from coal for 2008-2012 and that the fleet could be

National Coal Council – Reliable & Resilient: The Value of Our Existing Coal Fleet

replaced in 2020.^{vi} The increased cost of electricity in the first year of analysis (2020) is \$54 billion, and rises to \$90 billion per year in 2040, due to the increasing differential between the projected costs of coal versus gas. The first year cost, \$54 billion, is about 15% of the revenues from all retail electricity sales in 2011 (\$371 billion). A nominal 15% increase in the price of electricity would reduce U.S. GDP and employment by about 1.5%.³⁷ Current U.S. GDP is \$16 trillion per year (chained 2009 \$s), and non-farm employment is 137 million jobs.³⁸ Hence a 1.5% change could result in a \$240 billion decline in GDP and loss of 2 million jobs.

Figure B.8. Value of Existing Coal Fleet: Electricity Cost Savings.



Another way of considering the value of the existing coal fleet is to compare the price of electricity in the U.S. to that of other free market nations. Table B.1 presents such a comparison.³⁹ European power costs are two to three times those in the U.S.^{vii}

^{vi} It would be impossible to marshal the resources necessary to replace the existing coal fleet by 2020. Nevertheless, the year 2020 was chosen to enable a simple, transparent first order cost assessment that, even with very conservative assumptions, demonstrates that the existing coal fleet provides substantial economic benefits to the nation.

^{vii} A significant part of the European Union (EU) price differential is believed to be based on taxes and fees levied in the EU to foster greater use of emerging renewable energy systems. These surcharges were estimated to total 20 billion euros in 2013. [Die Welt](#), November 6, 2013. Additionally, the delivered price of coal and natural gas are generally 2-4 times as much as in the U.S. ([Electric Power Monthly – March 2014](#), USDOE/EIA, March 21, 2014, <http://www.eia.gov/electricity/monthly/>; [Statistical Review of World](#)

National Coal Council – Reliable & Resilient: The Value of Our Existing Coal Fleet

Table B.1. Electricity Price in 2013, Cents/kWh.

Consumer class	Electricity Price in 2013, Cents/kWh						
	U.S.	Denmark	France	Germany	Italy	Spain	UK
Residential	12	42	20	41	32	31	24
Industrial	7	15	13	20	23	17	16

Lower cost electricity acts as a stimulus to the economy, providing more disposable income to consumers and creating a competitive edge for U.S. manufacturers supplying global markets. Further evidence of the value of the existing fleet can be seen in a visual comparison of states that have a large share of electricity generation from coal⁴⁰ (see Figure B.9), with states that have low retail electricity prices⁴¹ (see Figure B.10).

Given the importance of electricity to the economy, basic energy policy assessments, such as the Quadrennial Energy Review⁴² and the President’s Advanced Manufacturing Initiatives⁴³ should consider the impact of lower priced electricity facilitated by coal-fired power plants.

Just as importantly, coal provides economic stability and has been a crucial buffer to spiking gas prices. Over the past decade, natural gas prices have proven volatile indeed. In 2004, gas to produce electricity had doubled in just two years to reach \$5.50/thousand cubic feet (mcf).^{viii} Then it more than doubled again by 2008 to peak at \$12.41/mcf. By 2012, the price dropped to \$2.81/mcf and averaged \$4.44/mcf in 2013. The average price of gas delivered to electric power plants in January 2014 was \$7.21/mcf, 60% higher than the price in January 2013.⁴⁴ Average annual fuel prices since 2001 and projected future prices are presented in Figures B.11 and B.12.

This past winter has demonstrated that large price spikes remain a characteristic of natural gas:

- In New England, natural gas prices reached \$77/mcf or \$435 per barrel in oil equivalent terms, causing the switch from gas to oil power generation.⁴⁵
- In New York, natural gas prices reached \$90/mcf.⁴⁶
- In the Northwest, spot natural gas at Malin Hub in Oregon quadrupled from \$7.70 to almost \$30/mcf.⁴⁷
- Deliveries to the Algonquin Citygates rose to \$24.35, gas at Iroquois Waddington was quoted at \$21.70, gas on Tennessee Zone 6 200 L increased to \$29.72.⁴⁸
- The Northern Natural Ventura price reached \$43.82.⁴⁹

Energy 2013, BP, <http://www.bp.com/en/global/corporate/about-bp/energy-economics/statistical-review-of-world-energy-2013.html>.)

^{viii} This report usually states natural gas prices in dollars per million Btu’s (\$/MMBtu), so that they are directly comparable to other fuel prices. Prices will be reported in dollars per thousand cubic feet (\$/mcf) if those units were used in a referenced document. The relationship between the two metrics varies slightly with the heating value of natural gas, but is generally: \$1.00/MMBtu = \$1.02/mcf.

National Coal Council – Reliable & Resilient: The Value of Our Existing Coal Fleet

Figure B.9. Source of U.S. Electric Power (Data from DOE/EIA).

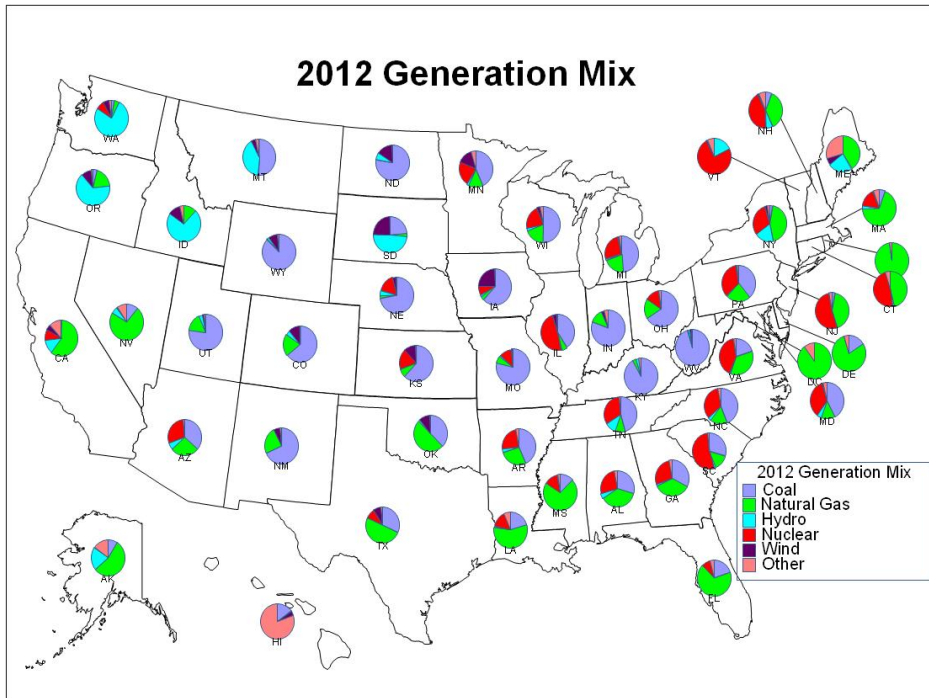
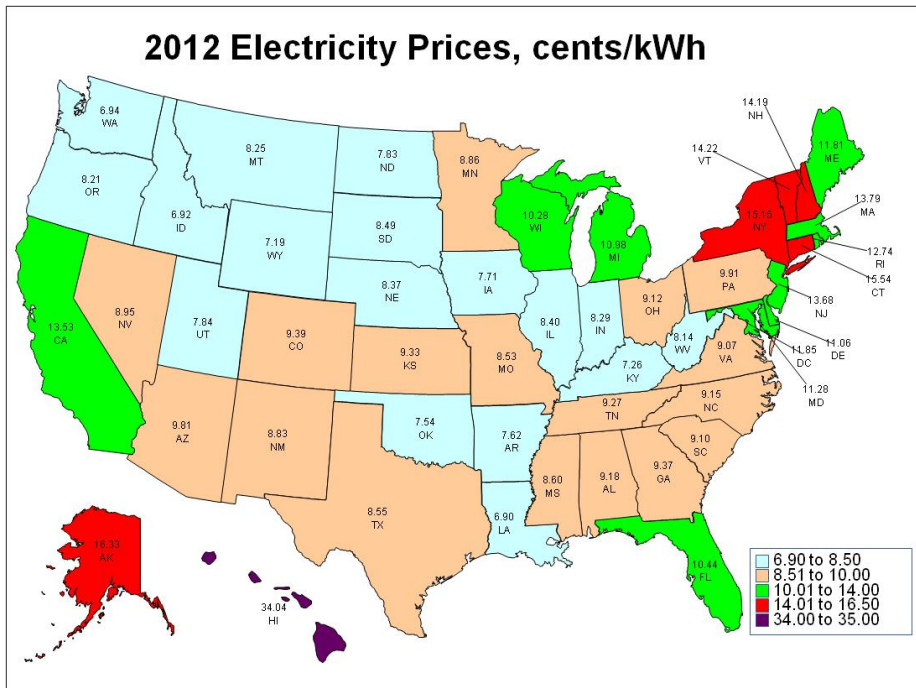

Figure B.10. Average Retail 2012 Electricity Prices, by State (Data from DOE/EIA).



National Coal Council – Reliable & Resilient: The Value of Our Existing Coal Fleet

Figure B.11. Fuel Price Volatility.

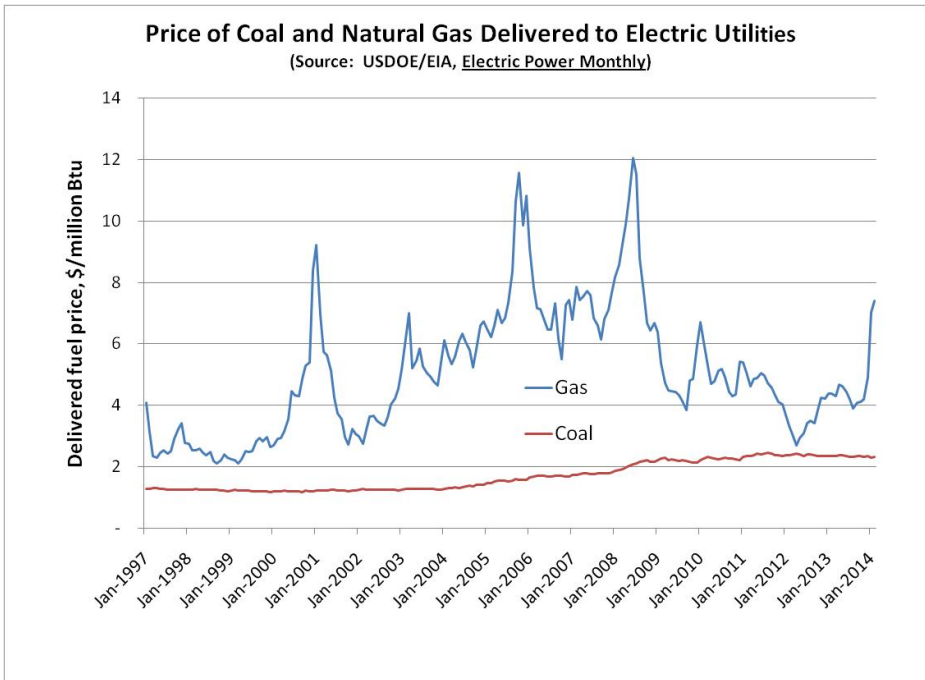
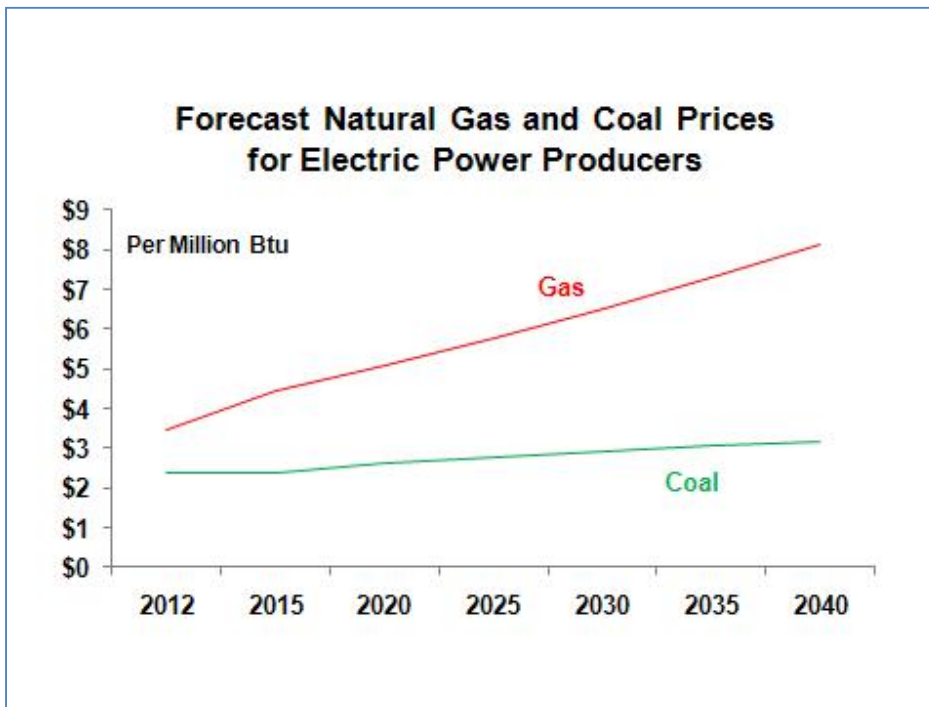

Figure B.12. Future Fuel Prices (Data from AEO-2014, DOE/EIA).



National Coal Council – Reliable & Resilient: The Value of Our Existing Coal Fleet

b. Supply and Price Stability Benefits

Energy supply and price stability are crucial elements in socioeconomic progress. The U.S. is still expanding, both in terms of population and GDP, and will continue to rely on its coal plants to meet electricity demand over the coming decades as the nation's population increases by almost 120 million by 2050. (See Figure B.13.) About 90% of the population will be urbanized.

Figure B.13. U.S. Population Change.

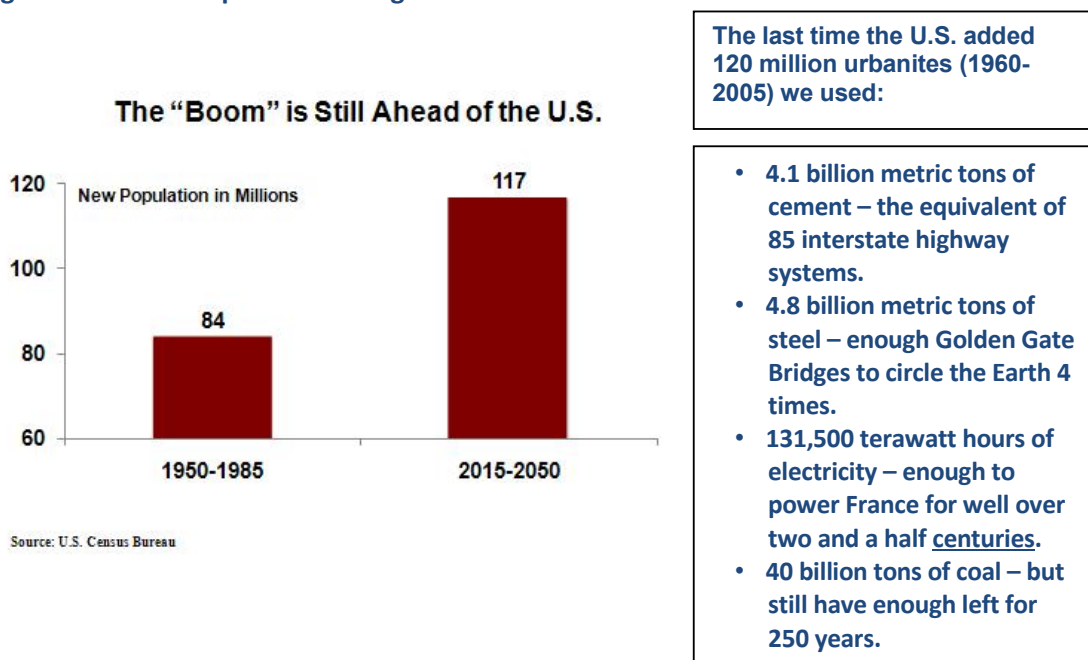

The U.S. will not be able to reliably and affordably meet growing demand without a balanced energy portfolio that includes coal. Coal has traditionally provided a buffer against higher electricity prices, and it could be argued that an expanded coal fleet will be needed to meet the needs of the American people. By 2030 alone, the EIA projects that population will grow by over 40 million, GDP will increase by almost 50% and at least 27 million new homes will be built. If electricity demand returns to the pre-recession growth rate, the U.S. would need an additional 1,300 TWH by 2030 -- as much as the power consumption of France, Germany and the United Kingdom *combined*.

The energy burdens of low-income households are much higher than those of higher-income families. Energy burden is a function of income and energy expenditures. As shown in Figure B.14, households with the lowest incomes have the highest relative energy costs.

National Coal Council – Reliable & Resilient: The Value of Our Existing Coal Fleet

Figure B.14. Impact of Energy on Discretionary Income.

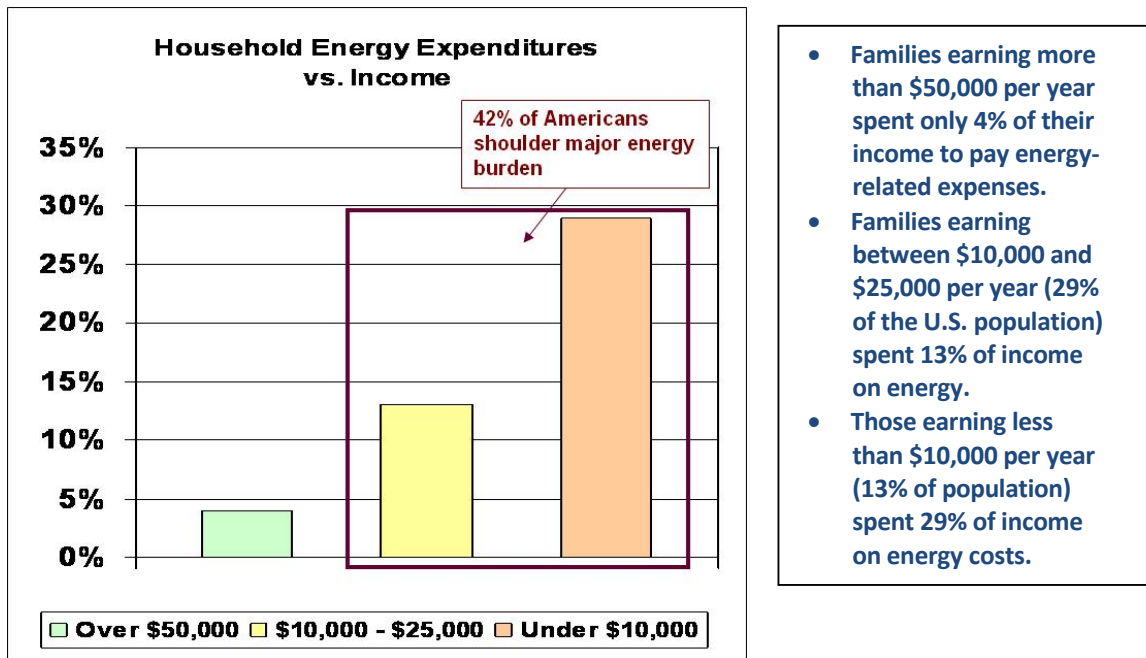

Source: American Association of Blacks in Energy.

Thus, for 42% of households – mostly senior citizens, single parents and minorities – increased energy costs force hard decisions about what bills to pay: housing, food, education, health care and other necessities. Cost increases for any basic necessity are regressive in nature, since expenditures for essentials such as energy consume larger shares of the budgets of low-income families than they do for those of higher-income families. Whereas higher-income families may be able to trade off luxury goods in order to afford the higher cost of consuming a necessity such as energy, low-income families will always be forced to trade off basic necessities to afford the higher-cost good. Over 90 million Americans are currently eligible for energy subsidies under the Low Income Home Energy Assistance Program (LIHEAP), a program administered by state agencies but primarily funded by U.S. Department of Health and Human Services grants.

America's coal endowment, coupled with an established supply chain, provides the opportunity for socioeconomic progress to occur with energy security, power reliability, price stability and affordability. The U.S. has 27% of the world's proven coal reserves. Figure B.15 shows distribution of coal resources throughout the U.S. The *National Academy of Sciences* has stated: "U.S. recoverable reserves of coal are well over 200 times the current annual production of 1 billion tons and additional identified resources are much larger. Thus, the coal resource base is unlikely to constrain coal use for many decades to come." In 2013, the U.S. produced an estimated 1,022 million short tons of coal, exported 116 million tons and imported 9 million tons. A total of 942 million short tons were domestically consumed of which 93% (874 million) was used to generate electricity.

National Coal Council – Reliable & Resilient: The Value of Our Existing Coal Fleet

Figure B.15. 30% of Global Coal is in the U.S.

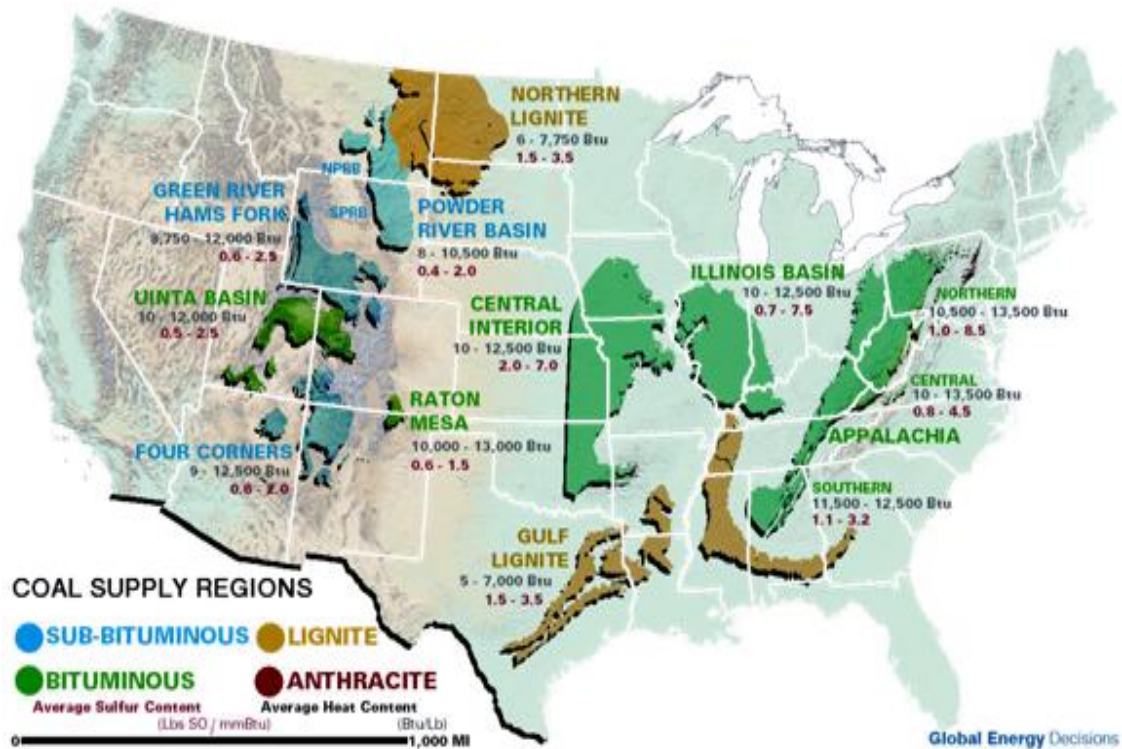

Over the past 150 years, the U.S. has built a vast infrastructure for extracting, transporting and utilizing coal for electric power, as the map in Figure B.16 indicates. The U.S. coal-fueled electricity generation supply chain is unmatched in the world. Research at Penn State University estimated the U.S. coal power supply chain provides over \$1 trillion in gross economic output, 7% of U.S. GDP, 6.8 million jobs (5% of the U.S. workforce) and \$362 billion in annual household income.⁵⁰

National Coal Council – Reliable & Resilient: The Value of Our Existing Coal Fleet

Figure B.16. The U.S. Coal-Fueled Electricity Supply Chain.

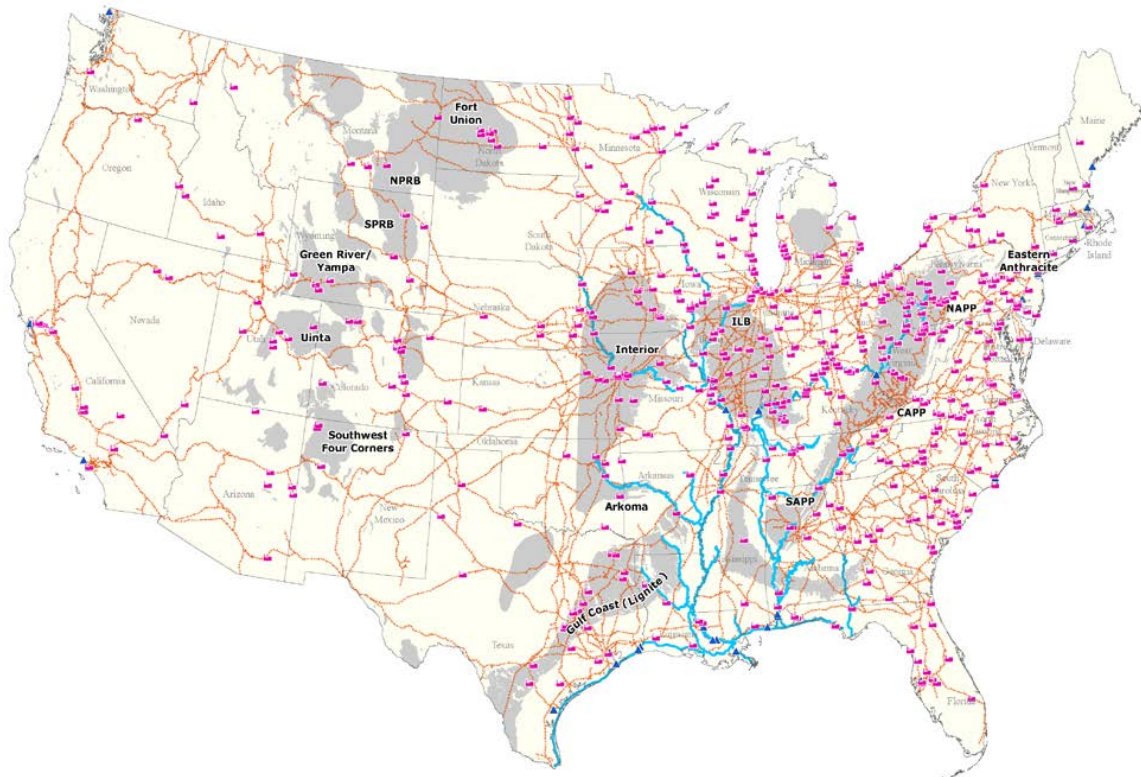

Figure courtesy of Peabody Energy.

- 1,200+ active coal mines
- 95,000 miles of Class 1 railroads
- 12,000 miles of commercially navigable waterways
- 90,000 miners

"There are many areas of the country that either 1) have insufficient access to natural gas, 2) do not have suitable sites for CO₂ storage or enhanced oil recovery sites, or 3) cannot be supplied wholesale power reliably through the existing transmission grid. How will the EPA reconcile elimination of new coal-fired capacity in these situations?"

National Rural Electric Cooperatives Association (NRECA)

National Coal Council – Reliable & Resilient: The Value of Our Existing Coal Fleet

In *Implications of Greater Reliance on Natural Gas for Electricity Generation (2010)*, the American Public Power Association (APPA) demonstrated the prohibitive infrastructure cost of replacing coal with gas.

- Supply concerns: Just to replace coal power, the U.S. would need an additional 14 trillion cubic feet of gas – equivalent to the combined production of Texas, Louisiana, Oklahoma and the Gulf of Mexico.
- Infrastructure concerns: Merely to build the power plants, pipeline system and storage infrastructure necessary to provide reliable gas would require an outlay of over \$800 billion (2014 dollars).
- It would be physically challenging within any reasonable time frame, given the geology for storage.
- Gas price escalation concerns: EIA projects that natural gas will cost \$4.77 per million Btu in 2020. The APPA estimates that over the long term it would cost \$11/MMBtu (2014 dollars) simply to replace depleting reserves.

Continuing to close affordable base load coal generation will not only mean higher electric rates, but also higher manufacturing costs and increased heating costs for over 55 million families who heat with gas.

“There's nothing like a cold winter to remind utilities of the value of their coal fleet.”

Paul Forward, Managing Director, Stifel Financial

c. Environmental Benefits

Continuous technology improvements have greatly reduced key emissions in the context of substantial increases in coal generation. Clean coal technologies work. The White House report, *The Blueprint for a Secure Energy Future* in March 2012 concluded: “implementation of clean, state-of-the-art coal-based technologies will help insure America’s energy security.” The CURC/EPRI coal technology roadmap found that, “Over the last 40 years, technology advances have led to impressive improvements in coal’s environmental “footprint.” For example, 93% of coal-fired power plants in the U.S. have installed, or are now in the process of installing, low NOx burners and other technologies which dramatically reduce power plant emission of nitrogen oxides. Reductions in emissions of SO₂ are even more dramatic.”⁵¹

The U.S. has shown that additional coal can be used to produce more electricity, more efficiently, while reducing emissions. Today’s clean coal technologies drive enormous environmental improvement. Since 1970, coal used for electricity increased substantially alongside a doubling of GDP as key emissions have decreased almost 90%. State-of-the-art technologies have reduced emissions of SO₂ by 88%, NOx by 82% and particulates by 96%. (See Figure B.17.) A combination of all of these technologies, in addition to use of sorbent injection systems, also enables highly efficient mercury removal. Utilities have invested more than \$100 billion in these technologies in recent decades.

Figure B.17. Coal Use and Declining Emissions.

Clean Coal Technologies Improve Air Quality

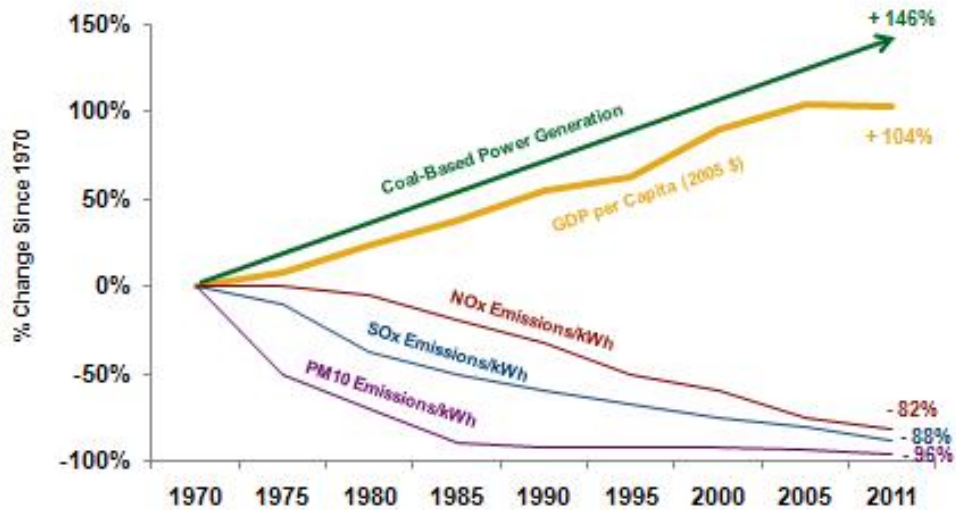

Source: USDA 2012, EIA 2012, NETL 2012

Supercritical power plants such as Prairie State (Illinois) and ultra-supercritical plants like AEP’s John W. Turk, Jr. plant (Arkansas) are the technological pathway to even lower emissions and the necessary precursor to carbon capture and storage. Figure B.18 shows the emission rate of recently permitted or constructed coal-fueled power plants compared to average emission rates. Although not shown in the figure, CO₂ emissions from new supercritical or ultra-supercritical steam units can be as much as 25% lower than from the oldest operating U.S. coal plants.

Figure B.18. Power Plant Emission Trends.

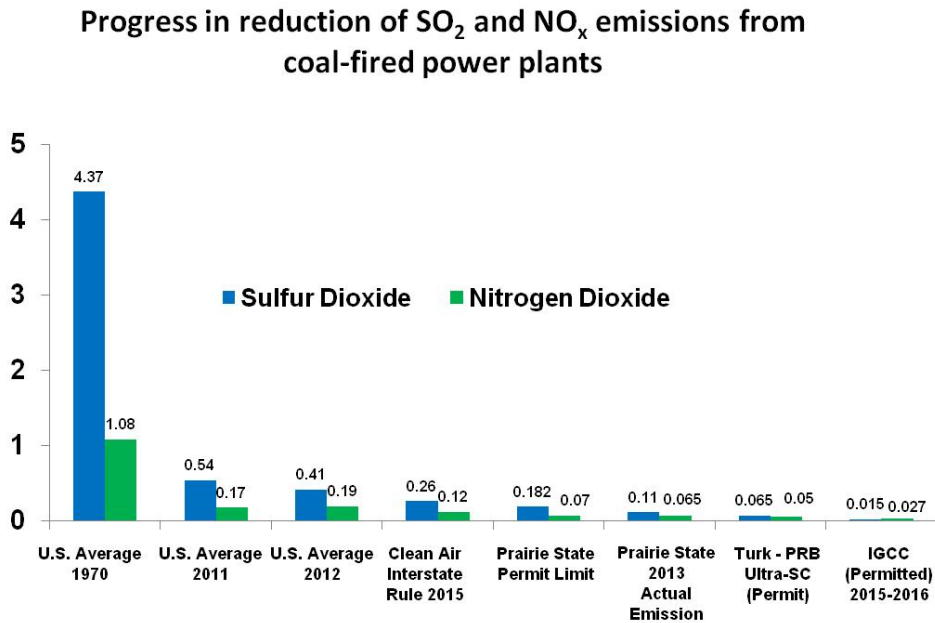

Currently available CCS technologies, resulting in 70-80% increases in the levelized wholesale cost of electricity compared to the same unit without CCS, are economically impractical in the absence of government subsidies. If such costly CCS technologies were broadly deployed, the increase in wholesale electricity costs would cause a profound increase in retail electricity prices. These extreme costs constitute a “call to action” to develop much less expensive CCS technologies.

“We’re looking at something on the order of \$70-90 a ton. In that context, that looks something like a 70-80% increase on the wholesale price of electricity.” –
Julio Friedmann
Deputy Assistant Secretary for Clean Coal, DOE

d. Carbon Capture, Utilization and Storage (CCUS)

The use of CO₂ for EOR is the CCUS approach providing the greatest potential for economic and environmental pay off over the next several decades. Enhanced oil recovery depends upon adequate supplies of CO₂. The only way to obtain CO₂ at scale is through carbon capture and utilization from coal power plants.

DOE-sponsored research found that “next generation” CCUS and EOR technologies would enable the economic recovery of 67 billion barrels of “stranded oil” which could be produced assuming an \$85/barrel oil price. In addition, there is emerging recognition that the Residual Oil Zone (ROZ) resources are enormous and could yield yet another 33 billion barrels for a total of at least 100 billion barrels of oil that would otherwise remain unavailable.

But the *sine qua non* of such recovery is the availability of adequate amounts of CO₂. New EOR projects are being delayed due to a lack of CO₂. Advanced Resources International (ARI)

National Coal Council – Reliable & Resilient: The Value of Our Existing Coal Fleet

estimates that as much as 20 billion metric tons of CO₂ will be needed to produce this recoverable resource, and if potential ROZ production is included, the required CO₂ exceeds 33 billion metric tons. However, only about 2 billion metric tons of CO₂ will be available from natural sources and natural gas processing. Coal-based CCUS technologies can help meet this 31 billion metric ton shortfall^{ix} to enable the U.S. to produce domestic petroleum resources and avoid reliance on the imported oil that severely impacts our trade balance of payments and national security. Many of the 310 GW of existing coal-based generation units can serve as the foundation for the vast amounts of CO₂ required, pending development of adequate pipelines and infrastructure. And, since coal generation will continue to be a leading source of electric power, it will provide a steady, affordable and reliable source of CO₂ if the technology is further developed and commercialized.

Clean Coal Technology Job Benefits: Part of the Secretary of Energy’s request of the National Coal Council was to “address the jobs implications of modification and addition of equipment at existing coal fired power plants.” A major factor defining the impact of such employment impacts is the extent of efficiency improving measures to be deployed on the existing coal-fired power plant fleet. This report does not attempt to project a likely average efficiency improvement for the fleet due to several major uncertainties, including:

- The extent to which recognized efficiency improving measures have already been deployed,
- Site-specific technical and economic barriers to potential efficiency improving measures,
- The degree to which efficiency improving measures would be deterred by current policies regarding NSR “major modifications,” and the possibility that such policies might be changed in order to realize the benefits of efficiency improvements,
- The cost, performance and applicability of some potential efficiency measures, such as adding a topping cycle to an existing unit, and
- The potential loss in efficiency due to future operation of existing coal-fired power plants at reduced load, or with additional emission reduction hardware.

Nevertheless, others have projected potential changes in coal fleet efficiency. For example, although it is unclear whether, and if so to what extent, the above uncertainties have been taken into account, EPA has offered the following estimate of potential efficiency improvements: “A reasonable expectation for individual plants would be a 2 to 5 percent reduction [in heat rate], considering site-specific constraints. More analysis is needed to consider costs and estimate a reasonable expectation for the average fleet-wide heat rate reduction, but it will likely be less than 5 percent.”⁵²

Management Information Services, Inc. (MISI)⁵³ estimated the cost of creating additional generating capacity via efficiency improvements and concluded that this was less than the cost of

^{ix} 31 Billion tonnes of CO₂ is roughly equivalent to 90% capture of all CO₂ generated by 110 GW of CCS-equipped coal-fueled power generation over a 40 year period. This equivalent capacity would vary depending on the number of years of operation, capacity factors and the energy requirements of the CCS system.

National Coal Council – Reliable & Resilient: The Value of Our Existing Coal Fleet

building new power plants. The resulting reduction in the projected cost of additional electricity was significant and showed that implementing efficiency measures on existing coal-fired power plants would have a stimulus effect on the overall U.S. economy. The employment increases from this “macro-economic” job impact of lower priced electricity was estimated to greatly exceed the jobs created by constructing and operating the efficiency projects. Overall, MISI projected that approximately 22,000 new jobs would be created for each percent reduction in overall fleet heat rate.

The EPA report and the MISI report can be considered together to offer a range of possible annual job impacts of potential efficiency measures applied to the existing fleet. By combining the jobs per percent reduction in heat rate, derived from the MISI report, with the range of heat rate reductions projected by EPA “for individual plants,” a range of up to 44,000 to 110,000 jobs can be projected.

4. Findings and Recommendations

a. Findings

- Electricity is essential to U.S. citizens’ economic well-being, health, safety and quality of life. Access to low-cost, reliable coal-fueled power generation enhances lives. The deployment of advanced coal technologies will be key to achieving our nation’s energy, economic and environmental goals.
- Coal’s domestic abundance, accessibility and low cost will ensure its continued leading role among U.S. power generation sources if coal’s environmental challenges can be met.
- The impending retirement of nearly 20% of the U.S. coal fleet by 2020 could put as many as 1 million jobs (or more) at risk.⁵⁴
- Coal fleet retirements will cause electric rates to increase significantly, and will be especially harmful to those states heavily dependent on coal – in these states, electric rates could increase 30-50% (or more).⁵⁵
- The U.S. existing coal fleet continues to play a vital role in meeting our nation’s electric power needs. The extreme cold weather events of the winter of 2013-2014 highlight the need to maintain a diverse portfolio of generation options in order to ensure the availability of affordable, reliable power for residential and industrial uses.
- Low-cost generation, such as that produced by the existing coal-fired generating fleet, is especially vital to ease the burdens of low-income and fixed-income households.
- The historical deployment of advanced coal technologies demonstrates that coal generation can be increased while simultaneously reducing emissions.
- Retrofitting advanced environmental technologies and enhancing efficiency at existing coal plants could result in the annual creation of 44,000 – 110,000 jobs, depending on the degree of efficiency improvement achieved.

National Coal Council – Reliable & Resilient: The Value of Our Existing Coal Fleet

b. Recommendations

- DOE should lead collaborative efforts with FERC and industry to assess the impacts of the 2014 polar vortex experience on power prices, availability and reliability.
- DOE should ensure that basic federal energy policy assessments, such as the Quadrennial Energy Review⁵⁶ and the President’s Advanced Manufacturing Initiatives⁵⁷ consider the impact of lower priced electricity facilitated by coal-fired power plants, and include an assessment of the value of diversity of generation sources and how pending coal plant retirements are likely to impact power prices, availability and reliability.
- DOE should lead collaborative efforts with industry to evaluate the implications of generation diversity on the President’s advanced manufacturing initiatives and efforts to enhance the global competitiveness of U.S. manufacturers.

C. Changes that Could Impact Future Benefits from the Existing Coal Fleet

1. Reduced Rate of Demand for Electricity

Growth in electricity demand reflects to some degree growth in the U.S. economy. Figure C.1 shows U.S. GDP in the post-World War II period.⁵⁸ Economic growth in the 1950s and 1960s averaged 4.3%/year, whereas it averaged 2.6%/year over the past 20 years and 1.2% over the past 5 years. Figure C.2 shows annual electricity generation since 1950, and the growth rate of generation (in a 5-year moving average).⁵⁹

Electricity demand grew at 6-11%/year during the 1950s and 1960s, at 2.5% or less since 1995, and was actually negative in 2009, 2011 and 2012. In addition to the overall lower growth rate of the economy, recent demand for electricity has also been affected by demand-side energy efficiency measures, a continuing shift from manufacturing to services and, within the manufacturing sector, to less energy intensive manufacturing. Looking to the future, EIA's most recent projections assume GDP growth of 2.4%/year for 2012-2040, and Electric Power Sector generation growth of 0.8%/year.⁶⁰ **This relatively low rate of growth in electric power demand emphasizes the importance of providing policies and technologies that preserve the existing fleet's benefits and portfolio value.**

Many analysts agree that to solve its current economic and financial problems, the U.S. will have to start producing more and exporting more and will have to reverse the decades-long atrophy of its manufacturing sector.⁶¹ The U.S. will no longer be able to shift its energy-intensive production activities abroad and will thus require significantly more reliable, reasonably priced electricity in the coming years – electricity that is not subject to cut-offs and wild price spikes. Much of this low cost reliable electricity will have to be provided by coal.

National Coal Council – Reliable & Resilient: The Value of Our Existing Coal Fleet

Figure C.1. U.S. GDP: 1947-2013.

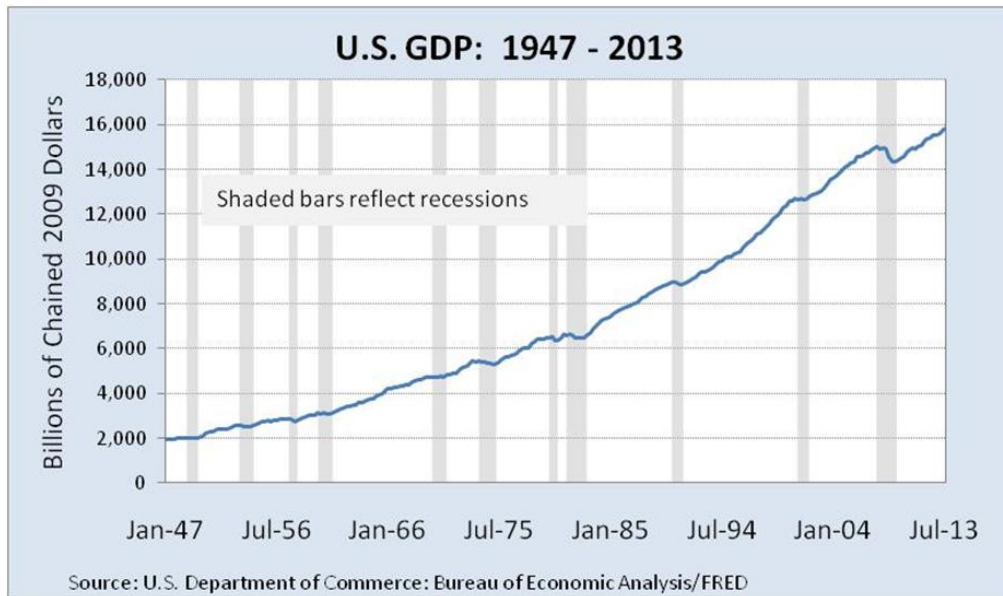
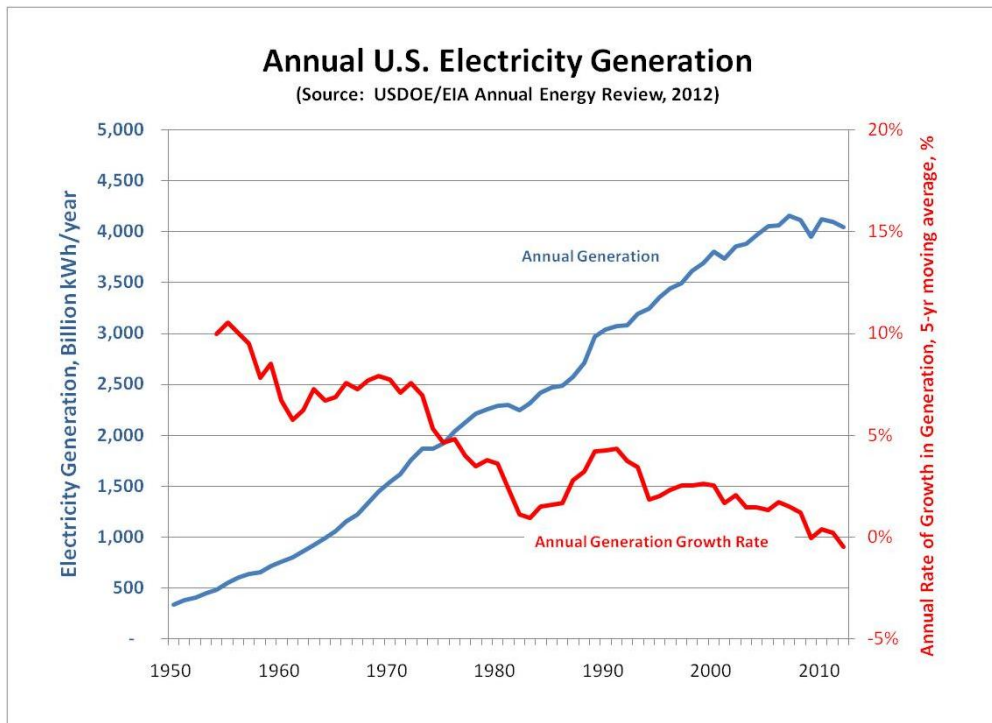

Figure C.2. Annual U.S. Electricity Generation.



National Coal Council – Reliable & Resilient: The Value of Our Existing Coal Fleet

2. More Advantageous Natural Gas Prices

Recent use of the existing coal fleet has been influenced by a dramatic decrease in the price of natural gas, and a resulting decrease in the cost of electricity from NGCC generation. Figure C.3 shows EIA data for power generation from coal and gas between July 2011 and July 2013.⁶² Note that during 2012, coal-fired generation dropped sharply from coal's rolling 4 year average, while the opposite occurred for natural gas generation. Coal's share of generation recovered somewhat in 2013. Figure C.4 shows the corresponding spot prices for natural gas during these periods: lower in 2012, and higher in 2013.⁶³

Future natural gas prices are uncertain. They could be influenced by environmental regulations on gas production and its use in power plants, by larger exports of liquefied natural gas (LNG) and by the need for expanded pipeline and gas storage infrastructure. Additionally, much of the existing natural gas infrastructure is aging and in need of maintenance. Over half the nation's pipelines are over 50 years old; the leak rate in gas mains is one every 8 miles per year, and one leak every 2 miles for services lines.⁶⁴ **EIA's most recent projections for the price of delivered gas to electric utilities indicate an expected real (constant dollar) increase of 3.1%/year, for 2012-2040, versus 1.0%/year for coal.** It should be noted that past natural gas price projections have been inaccurate. Figure C.5 shows a retrospective accounting of past EIA projections versus the actual price of natural gas (the heavy black line in Figure C.5).⁶⁵ An ability to make accurate projections of future natural gas prices is relevant to the existing coal fleet, because retirement decisions for existing coal capacity will rely in part on projected costs for coal and natural gas.

Figure C.3. Monthly Generation from Natural Gas and Coal.

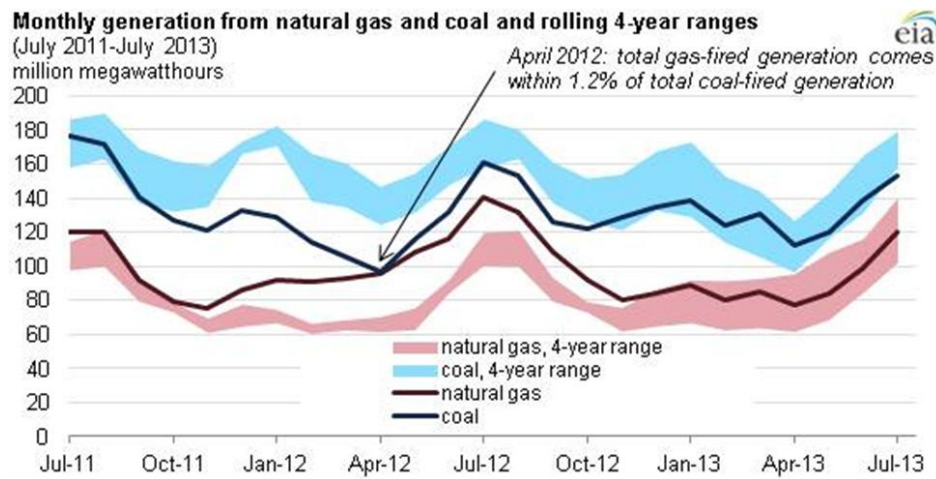

National Coal Council – Reliable & Resilient: The Value of Our Existing Coal Fleet

Figure C.4. Henry Hub Spot Prices.

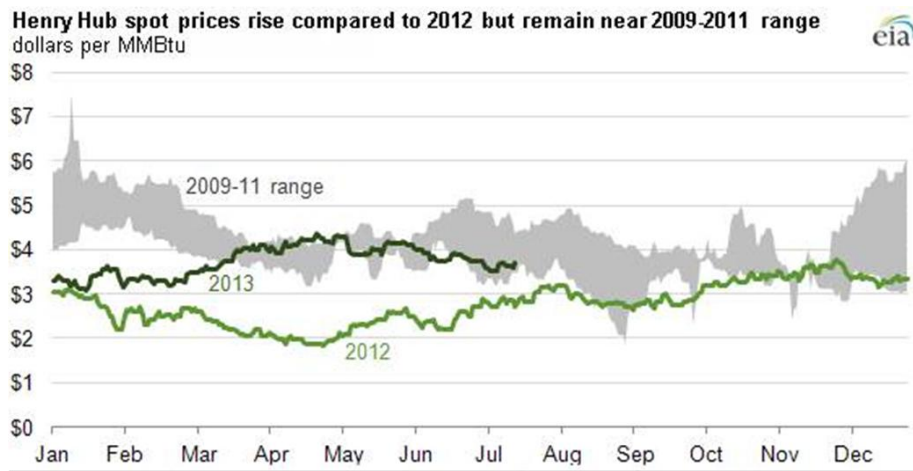
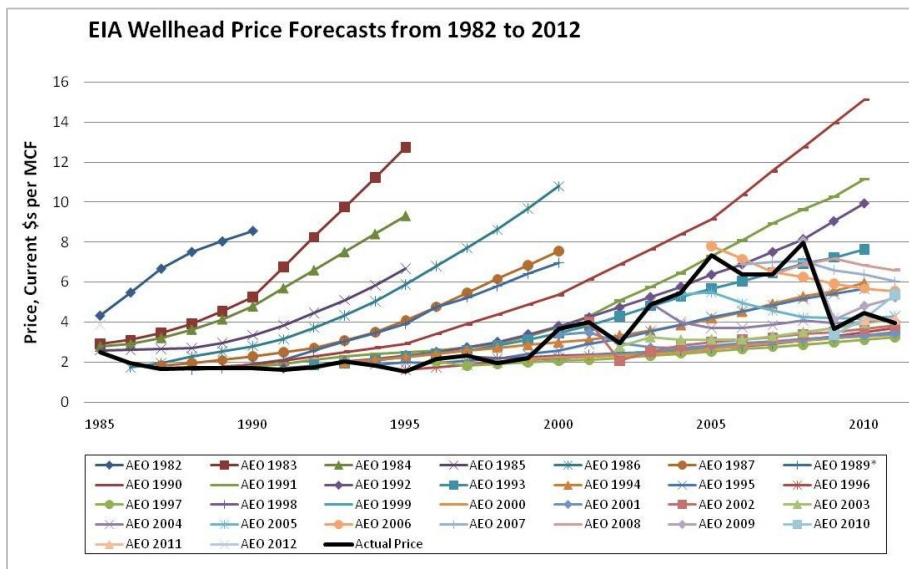

Figure C.5. Natural Gas Price Predictions Versus Actual Price.



National Coal Council – Reliable & Resilient: The Value of Our Existing Coal Fleet

3. Environmental Regulation

A number of new and emerging environmental regulations for the existing coal fleet will reduce operating flexibility and will require the implementation of very expensive compliance strategies. Taken together, these regulations are a major driver of decisions to retire approximately 20% of the existing coal fleet by 2020.⁶⁶ Future behavior is speculative; but since only a portion of the expected regulations have been promulgated, it is reasonable to conclude that the amount of retiring capacity will increase, absent the development of much more cost-effective compliance technologies.

a. Non-CO₂ Regulations

Since 2011, EPA has promulgated a series of new regulations impacting the electric power sector. Perhaps most significant are the Cross State Air Pollution Rule (CSAPR) and MATS. Additionally, states have implemented new limitations based on improving visibility in Class I areas (National Parks, Wilderness Areas). Rules also have been proposed, but have not yet been promulgated, to revise effluent guidelines for certain wastewater streams from power plants, to revise regulations for cooling water intake structures (pursuant to Section 316(b) of the Clean Water Act) and to revise coal combustion residuals (CCR) regulation under the Resource Conservation and Recovery Act (RCRA). EPA is also developing new rules, including a new ozone transport rule, and revisions to National Ambient Air Quality Standards (NAAQS) that could ultimately require revisions to State Implementation Plans to reduce emissions of SO₂ and NO_x from power plants. Strategies to comply with these new requirements will be expensive and will increase the operating costs and potentially impact the performance of the existing coal generation fleet.

b. CO₂ Limitations

In January 2014, EPA proposed NSPS for CO₂ emissions from new fossil fuel-based power plants. The limitation that would apply to coal-fueled power plants was 1,100 lb-CO₂/MWh (gross), a rate that would effectively require use of “partial” CCS. EPA has committed to proposing guidelines under the authority of Clean Air Act Section 111(d) for state regulation of CO₂ emissions from existing coal-fueled power plants. This regulatory package was sent to the Office of Management and Budget (OMB) for the pre-proposal interagency review on March 31, 2014.⁶⁷ These regulatory guidelines are scheduled to be proposed in June 2014 and promulgated in June 2015.⁶⁸

“The electric industry is becoming more complex due to political and societal drivers propelling new policies, such as a carbon-reduced resource portfolio.”

“The uncertainty increases with the potential for carbon emission limitations.... It is evident that continued policies aimed at limiting carbon emissions will impact the coal generation fleet in MISO, increasing the potential for resource deficiencies and corresponding reliability impacts.”

“Reliability factors other than capacity and energy requirements can be more difficult to address; for example, the ability of the bulk power system to withstand disturbances and remain in compliance with NERC Reliability Standards. These and other less obvious reliability concerns are further exacerbated by the continued retirement of steam-driven generators.”

“Early retirement of multiple units in the short run can stress the bulk power system....”

[2013 Long-Term Reliability Assessment, NERC, Dec 2013](#)

National Coal Council – Reliable & Resilient: The Value of Our Existing Coal Fleet

In addition to federal regulations, some states have regulatory programs that require reductions in CO₂ emissions from power plants. California has adopted a “Cap and Trade” system that includes power plants, as well as other source categories. Nine northeastern states have a collaborative program that applies only to power plants (the Regional Greenhouse Gas Initiative, or RGGI).

Separate from the near-term NSPS goals, the Administration has stated a long-term goal of reducing U.S. GHG emissions by 83% below 2005 emission rates by 2050.⁶⁹ Meeting such a goal will be difficult in the absence of CCS technology. The Intergovernmental Panel on Climate Change (IPCC) recently issued its Fifth Assessment Report, comprised of a series of working group reports addressing knowledge related to climate change. Contributors to the report modeled mitigation efforts necessary to meet various atmospheric CO₂ concentration targets, using a range of models. They found that, “many models cannot reach 450 ppm CO₂eq concentration by 2100 in the absence of CCS.” For those models that could reach the mitigation goal without the availability of CCS technology, the cost of doing so was 138% greater (more than double) without CCS technology than with CCS technology.⁷⁰

c. Other Related Regulations

The District of Columbia and 29 states have adopted Renewable Portfolio Standards (RPS), rules that require a certain percentage of a state’s power generation to derive from renewable energy (wind, solar, biomass, etc.). An additional eight states have set renewable portfolio goals, rather than enforceable standards.⁷¹ Similarly, 20 states have adopted Energy Efficiency Resource Standards (EERS) that take different forms, but generally require electric utilities to encourage end use efficiency systems (more efficient appliances and electrical devices, building insulation, etc.). These regulations introduce additional pressures to operate the existing coal generating fleet less or in a less efficient manner (due to cycling, minimum load, etc.).

d. Cumulative Impacts

All of the regulations now under consideration by EPA have not yet been promulgated, so their cumulative impact is unknown at this time. The EIA reports that 10 GW of coal capacity retired in 2012, and projects another 50 GW to retire by 2020, based on a combination of market forces and regulations which have been adopted through 2013.⁷² The potential significance of future CO₂ regulations on the existing fleet can be gleaned from the EIA’s assessment of GHG scenarios in the Annual Energy Outlook 2013 (AEO2013). For carbon fees (or taxes) ranging from \$10 per tonne CO₂ to \$25 per tonne CO₂ in 2014 (increasing at 5% per year above inflation), U.S. coal-fueled power generation would decrease between 35% and 98% in 2040, compared to generation in 2010.⁷³

4. New Source Review – Major Modifications

Under EPA’s NSR program, major new sources, and major modifications of existing sources, must obtain preconstruction permits that contain a requirement to apply state-of-the-art air pollution control technology (among other requirements). As observed by the National Research Council in a report prepared for EPA, “NSR’s treatment of modifications has been particularly controversial.”⁷⁴ In general a physical change (that is not considered to be “routine maintenance, repair or replacement” under the Agency’s rules), or a change in the method of operation, at a

National Coal Council – Reliable & Resilient: The Value of Our Existing Coal Fleet

major source that causes a significant net increase in emissions will trigger NSR. Much of the controversy regarding NSR lies in determining whether the change is non-routine maintenance, repair and replacement (or subject to certain other exclusions), and whether the change causes an increase in emissions. EPA has promulgated rules and definitions⁷⁵ that guide the source owner and the permitting authority in making determinations regarding major modifications. Unfortunately, these rules have been so controversial, at least since the late 1990s, that the very uncertainty created by them works as a powerful disincentive for utilities to undertake projects that might trigger NSR, or to conduct the research necessary to develop additional efficiency innovations. Moreover, the requirement for a modified facility to obtain a permit before any construction activity may commence and to apply the “best available control technology” (BACT), among other requirements, serve as a strong economic disincentive to making such changes at an existing power plant.

Beginning in 1999, EPA launched a major enforcement initiative against electric utilities for projects at existing coal-fired power plants, which EPA believed to have violated the Agency’s NSR regulations. EPA estimated that by 2005, as a result of the ensuing litigation, the utility industry had committed to spend over \$5 billion on capital equipment to reduce emissions.⁷⁶ That enforcement initiative continues to the present.

The intricacies of NSR regulation are beyond the scope of this report, but the larger concepts are important to understand because they impact the development and potential use of some of the technologies being considered in this report. Specifically, under NSR as interpreted by EPA’s enforcement arm since the start of the enforcement initiative in the late 1990s, many of the technologies considered in this report would not be considered routine maintenance, repair, and replacement.

Intuitively, one might think that projects that improve efficiency, such as those considered in this report, would never trigger NSR even if they are considered “physical changes,” because they decrease emissions per unit of power produced. Unfortunately, that is not necessarily the case under NSR, because of the way the NSR rules define “emissions increase.”

As the rules currently stand and are enforced by EPA, such projects would trigger NSR if they result in an increase in emissions of any NSR-regulated pollutant (which includes “conventional” pollutants, such as SO₂, NO_x and particulate matter (PM), as well as greenhouse gases) on an annual basis. Thus, if the unit at issue is utilized more after the project than before (and that increased utilization is caused by the project, for example because the increased efficiency is so substantial that it makes the unit more attractive to run), the project could be said to result in an NSR emissions increase. The delay and cost associated with obtaining an NSR permit before the project may commence and with installing “BACT” would eliminate the project from consideration in the vast majority of cases.

EPA has confirmed the problem described above. The Agency has stated, for example, that “As applied to existing power plants and refineries, EPA concludes that the NSR program has impeded or resulted in the cancellation of projects which would maintain and improve reliability, efficiency and safety of existing energy capacity. Such discouragement results in lost capacity, as well as lost opportunities to improve energy efficiency and reduce air pollution.”⁷⁷ EPA explained that a major reason for these impacts was that “energy efficiency improvements are often associated

National Coal Council – Reliable & Resilient: The Value of Our Existing Coal Fleet

with increases in utilization, because the more efficient generating units are dispatched more often. Efficiency improvements can also result in an increase in capacity or availability. In such cases, there can be local emissions increases that trigger NSR if the projects are not routine maintenance.”⁷⁸

Assuming that overall electricity demand is unchanged, increased use of an efficient unit will lead to less use of another less efficient unit. In general, it is likely that the displaced generation will be from a less efficient coal unit so regional emissions could decline in the exchange. Hence, current rules could result in higher national emissions and continued degradation of efficiency within the existing fleet. Of course, a power plant owner could accept the additional requirements that come with NSR and make the efficiency improvement, but as stated by EPA: *“the costs associated with NSR, particularly the costs to retrofit pollution controls, can render these projects uneconomical. Thus, the EPA finds that NSR discourages some types of energy efficiency improvements when the benefit to the company of performing such improvements is outweighed by the costs to retrofit pollution controls or to take measures necessary to avoid a significant net emissions increase.”*⁷⁹

This is not a theoretical problem. At the start of the NSR enforcement initiative, EPA considered a “dense pack” project (a turbine upgrade technology marketed by GE) at Detroit Edison’s Monroe Plant.⁸⁰ In that case, Detroit Edison argued that the efficiency improvement was not substantial enough to change the unit’s loading order and thus potentially result in increased utilization of the unit. In particular, Detroit Edison noted that the units at issue were “already at the top of the loading order and had a capacity factor of approximately 85% for 1998.”⁸¹ Thus, the company concluded, any “increase in use would be the result of demand and unforeseen outages, which could and would have occurred regardless of whether or not Detroit Edison proceeds with the Dense Pack project.”⁸²

While it did not reject Detroit Edison’s claim outright (stating instead that the initial determination on the issue is the State agency’s), EPA indicated that it “disagree[d] that the dispatch position of the Monroe plant necessarily means that the Dense Pack project would not result in increased use, and hence, increased emissions.”⁸³

*Given the information provided by the company showing that there is some fluctuation in annual use and that Units 1 and 4 are not operated at their maximum physical capacity, the fact that Monroe is at the top of the loading order is insufficient to demonstrate that the significant increase in efficiency associated with the Dense Pack project, and the corresponding decrease in the cost of producing electricity, would not result in increased use and emissions.*⁸⁴

During the enforcement initiative that ensued in the following 13 years, EPA and environmental groups have sued several companies for efficiency improvement projects similar to Detroit Edison’s, as well as for less extensive turbine repair or replacement projects—e.g., turbine overhauls. A list of these cases and the specific claims at issue are included in Appendix A. This list is limited to turbine upgrades or replacements – the list would be much longer if improved materials of construction and improved designs of heat transfer surfaces were included.

National Coal Council – Reliable & Resilient: The Value of Our Existing Coal Fleet

In short, the fundamental barriers to improving power plant efficiency and reliability cited by EPA in its 2002 report remain in today’s NSR rules. The uncertainties created by the NSR rules, their enforcement by EPA and certain environmental groups against some of the very types of efficiency improvement projects considered in this report, and the very substantial—even prohibitive—cost of NSR create strong disincentives to the widespread deployment of such measures.

5. Aging of Fleet

Figure C.6 shows the rapid growth of coal-fired power generation in the U.S. between 1950 and 1980, and the limited additional growth thereafter. Although there is no fixed general endpoint for the useful life of a coal-fired power plant, as a unit ages, large capital investments tend to become less attractive due to the unit’s remaining life. For investments with relatively rapid payback, typical of some efficiency and flexibility improvements, age is not a major issue. But for CCS retrofits and other large capital investments that do little to improve or prolong the existing power block, the remaining useful life of a unit can be an important factor influencing utilities’ decisions, and in regulated markets, utility commission approvals.^x Figure C.7 maps current coal-fired capacity by state, and Figure C.8 shows the capacity of units that will be less than 40 years old in 2025.⁸⁵ The earliest date by which 2nd Generation CCS technologies are projected to be available and economically competitive under the current RD&D schedule, is 2030.

Figure C.6. U.S. Coal-fueled Generating Capacity Additions.

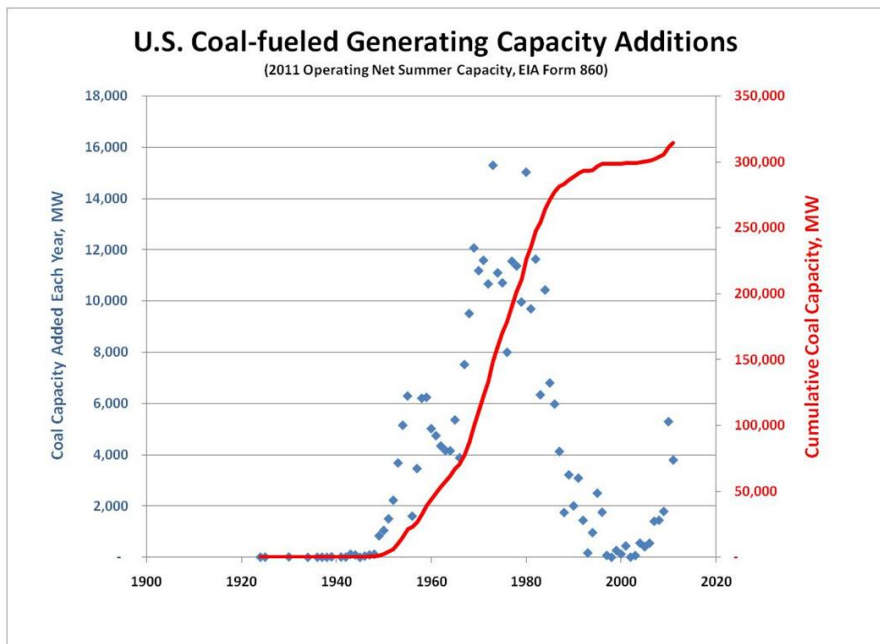

^x An examination of the expected technological and economic life of generating units in the existing coal fleet and the influence of those factors on decisions regarding capital investments in an existing generating unit would be a useful subject for future analysis.

National Coal Council – Reliable & Resilient: The Value of Our Existing Coal Fleet

Figure C.7. Coal Generating Capacity, by State (based on EIA-Fm860 data).

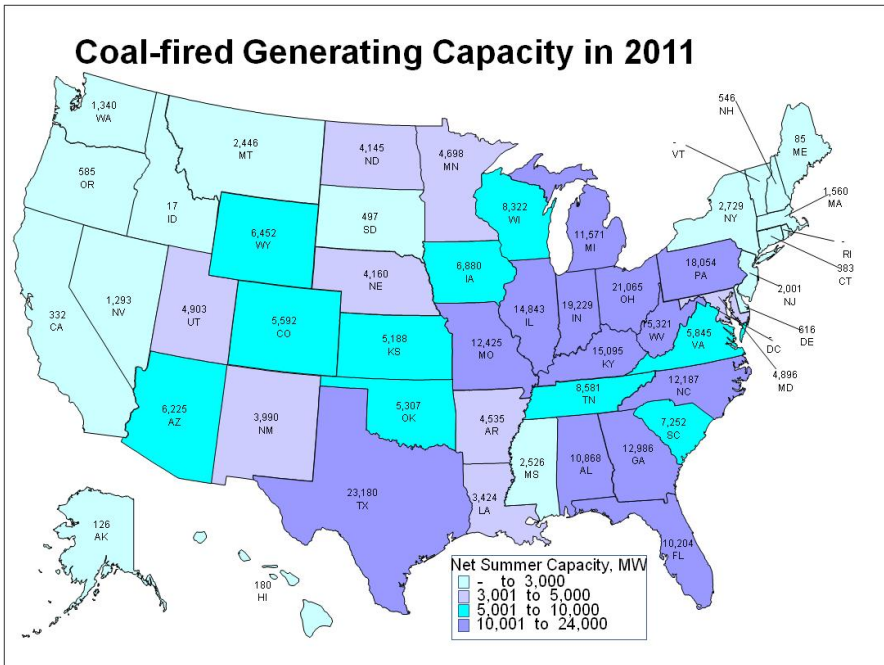
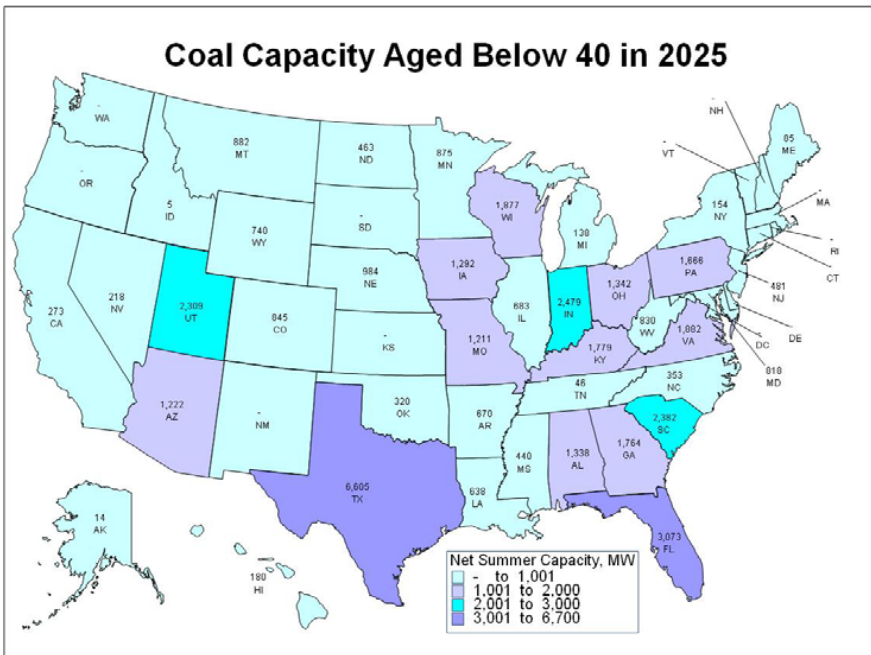

Figure C.8. Projected Coal Capacity in 2025 (based on EIA-Fm860 data).



National Coal Council – Reliable & Resilient: The Value of Our Existing Coal Fleet

6. Reduced Funds for R&D (Industry & Government)

The technology scope of DOE’s coal RD&D program has remained relatively constant since 2004, focusing primarily on advanced, more efficient, power systems and CCS. Funding has varied from year to year, with external R&D^{xi} ranging from about \$300 million to \$400 million per year for 2004-2014. Federal funds for cost-shared commercial-scale demonstration projects ranged from \$50 million to \$290 million per year for 2004-2009, and an additional \$3.4 billion was provided for demonstration projects under the American Recovery and Reinvestment Act (ARRA) of 2009. No additional demonstration project funding has been appropriated since 2009. It should be noted that \$370 million of these appropriated funds were lost through budget rescissions, and \$145 million of ARRA funding was returned to the Treasury Department because of cancellation of a demonstration project. Figure C.9 shows the combination of R&D, demonstration, and fund rescission, by year, for FY04-FY14, and the Administration’s budget request for FY15. If all of these sources and losses are combined, including the ARRA funds, the average federal appropriation for coal RD&D for 2004-2014 was \$675 million per year.

In contrast, the Administration’s coal RD&D budget request for FY 2015 is \$277 million, of which \$243 million is for external (cost shared) RD&D (the remainder is for National Energy Technology Laboratory (NETL) salaries and other aspects of NETL in-house R&D). This represents a decrease of approximately 64% compared to the average appropriations for the previous 11 years. \$243 million represents 0.9% of the Administration’s total budget request for DOE in FY2015.

Figure C.9. DOE RD&D Budget for Coal Use Technologies.

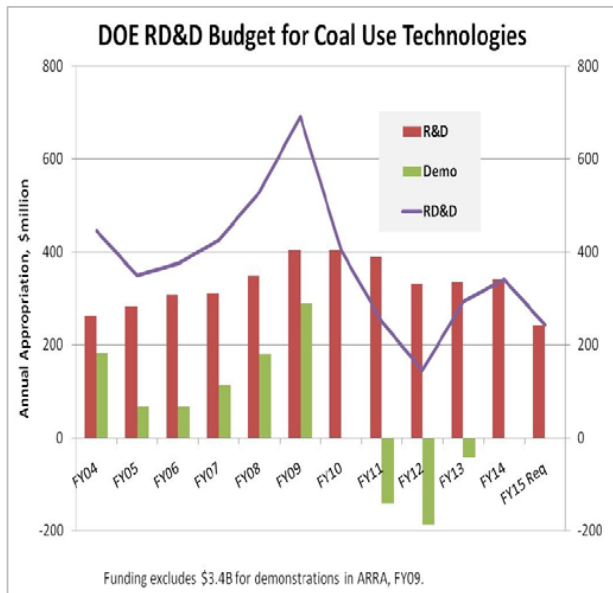

^{xi} External R&D is defined as cost-shared collaborative activities with industry, and is in contrast to in-house R&D funding for research performed at NETL, typically about \$35 million per year. The distinction is made because DOE’s accounting protocol for these funds changed in FY2009.

National Coal Council – Reliable & Resilient: The Value of Our Existing Coal Fleet

Overall, the Administration’s FY2015 budget request for discretionary activities by DOE increased by 2.7% above FY2014 appropriations, to \$27.9 billion. The request for Energy Efficiency and Renewable Energy (EERE) increased by 22% to \$2.3 billion.⁸⁶ In 2013, coal generated 1,586 million MWH of electricity; non-hydro renewable energy generated 253 million MWH of electricity.⁸⁷

7. Findings and Recommendations

a. Findings

- While U.S. demand for electric power will continue to grow in the long term, the near-term more modest projected rates of growth reinforce the importance of advancing policies and technologies that preserve existing coal fleet investments.
- Natural gas prices continue to be volatile, reinforcing an historical trend. Increased reliance on natural gas for power generation will impact resource supply and price stability.
- Increasingly stringent environmental regulations will reduce operating flexibility, increase capital investment expenses and potentially impact plant performance for U.S. power generators.
- New Source Review regulations impact generators’ decisions and ability to enhance plant efficiency, reduce emissions and improve overall operations/capacity. The delay and cost associated with obtaining an NSR permit tend to eliminate efficiency enhancement projects as viable options.
- Many of the challenges facing the existing coal fleet are technology based, and would benefit from DOE-led collaborative RD&D with industry. Funding requirements, particularly for demonstration projects are significant.
- The IPCC concluded that reaching climate change goals without CCS will more than double the cost of mitigation.

b. Recommendations

- DOE should work with the EPA to eliminate New Source Review-related barriers that disincentivize generators to pursue efficiency improvements that would otherwise reduce emissions, increase capacity and enhance plant operations.
- DOE should seek input from industry research associations, such as the Electric Power Research Institute and the Coal Utilization Research Council regarding priority research needs and the appropriate balance between research, development and demonstration of technologies relevant to the existing coal fleet.

D. Technology Responses to Maximize Future Benefits to Society

1. General Introduction

Changing circumstances are challenging the ability of the existing coal fleet to provide benefits to society. In the past, similar challenges have been met with improved technologies. Past challenges to coal generation, such as the need to reduce emissions of sulfur dioxide, nitrogen oxides, and mercury, were met through collaborative efforts between the public sector and the private sector to develop new technologies.

The terms “Flue Gas Desulfurization”, “Selective Catalytic Reduction”, and “Activated Carbon Injection” were not part of the nation’s lexicon in 1970. Today, these systems, developed through industry/government collaboration, are standard equipment on new coal-fired power plants and have been widely deployed on existing units as well. Additionally, for every dollar of federal funds invested in coal RD&D, thirteen dollars of benefits accrued to the nation.⁸⁸ Moreover, RD&D in advanced coal technologies can produce products for sale abroad, enhancing U.S. manufacturing and improving the nation’s balance of trade.

Three families of technologies will be discussed in the remainder of this section:

- Measures to improve the flexibility and reliability of the existing coal fleet, particularly with respect to operating in non-base load modes.
- Measures to improve the efficiency of existing coal-fired power plants.
- Emission reduction technologies, both for traditional pollutants and CCS technologies for reducing CO₂ emissions from existing coal-fired power plants.

2. The Path to Improving the Flexibility & Maintaining the Reliability of the Existing Fleet

a. Background and Introduction

Most of the larger generating units in the existing coal-fired power plant fleet were designed to run as base load units. However, as these units continue to age, as relatively low-priced NGCC power enters the network and as renewable portfolio standards and renewable energy certificates lead to greater market penetration of renewable energy-based generation, these coal units are likely to be increasingly dispatched in a cycling mode, and incur more frequent startups and shutdowns. Even more efficient units such as supercritical units which were designed and operated historically as base load are now experiencing varying load and even reserve shutdown due to economic dispatch. Some of these very large units (up to 1300 megawatt equivalent (MWe) single units) had not experienced such dispatch changes until the past few years. As discussed below, this need for more flexible operation will require a range of actions by the power sector if these units are to continue to function with the reliability required by a modern electricity network.

In addition to the changing duty cycles, the fleet will need to adjust to comply with new environmental regulations. Moreover, for those units already configured with a full complement of environmental controls, changes may be necessary to maintain or enhance their level of performance in the non-steady state conditions associated with partial load operation.

National Coal Council – Reliable & Resilient: The Value of Our Existing Coal Fleet

b. Analysis and Discussion

Characteristics of the new mission for the existing coal units⁸⁹ include:

- Increased load-following operation
- Greater unit turndown during low demand
- Frequent unit starts (hot, warm and cold)
- Increased load and thermal ramp rates
- Frequent reserve shutdown
- Meeting more stringent emissions requirements

All of the above changes in duty cycle tend to reduce efficiency.

Regionally, many units vary from base load at some times of the year to intermittent or rapidly changing load patterns. Intermittent generation requirements on the system can contribute to the changing role of coal. Seasonal variation in wind and solar production can lead to higher turndown and/or reserve shutdown of balancing assets, including coal.⁹⁰ Variations in the output of these intermittent sources within a typical day can be rapid, and lead to load-following of coal units, frequent unit starts and, most importantly, increased frequency and rates of load ramping. The tendency for peak hourly wind generation to be out of phase with hourly trends in demand forces more coal units to run at minimum loads or shut down during the night, and ramp up and down to balance load.⁹¹

In addition to the inverse correlation between wind output and system demand often seen on an hourly basis for each day, there is a similar trend observed on a monthly basis throughout a typical year. These two factors can combine to result in a wide range of coal balancing load required between the extremes of renewable generation levels.

Analysis of NERC Generating Availability Data System (NERC-GADS) data reported by coal units in the 2005-2009 timeframe indicates an increase in reserve shutdown hours^{xii} in 2009. This is observed across a range of unit sizes, in both supercritical and subcritical designs. This had produced a reduction in reported net capacity factor, particularly for older subcritical units which are experiencing increased turn-down, low load operation. These impacts may be primarily driven by an overall demand reduction (4% from 2008 to 2009 according to EIA) and a shift in dispatch to gas-fired assets (gas-fired combined-cycle production net capacity factor increased by 5% from 2008 to 2009). However, displacement of coal by intermittent generation is already a factor in certain regions, with a growth in overall renewable generation of 18% from 2005 to 2009 reported by EIA.

A study conducted by the National Renewable Energy Laboratory (NREL) on wind and solar integration in the western states predicted a wide range in the level of coal-fired balancing load required during the time period of 2017 assuming a 35% renewable asset portfolio.⁹² These

^{xii} Reserve shutdown hours are the total number of hours a unit was available for service but not electrically connected to the transmission system for economic reasons.

National Coal Council – Reliable & Resilient: The Value of Our Existing Coal Fleet

balancing units would experience frequent starts, high turndown, ramping and reserve shutdown hours.

Exacerbating the challenge of increased need for flexibly operating coal units over time is the fact that many of the more flexible existing coal units will be retired or reduce their level of output. For example, a number of smaller units (often < 300 MWe) with higher design margins allowing flexibility are being retired. These units often have fewer existing emission controls, less sophisticated instruments and controls (I&C) and, in the past, have often dispatched in load balancing mode. These are often older, less efficient units, and are not cost-effective to upgrade to meet current emission standards. Approximately 40GW of the 60GW of coal units that have announced their retirement, or are considered probable retirements, are less than 300 MWE capacity.⁹³

Increased cyclical and low-load activity also will impact the operation of air emissions control systems (e. g., SCR, FGD and mercury controls), as well as wastewater treatments. The clearest example of a constraint on unit flexibility may be the addition of SCRs. These systems are analogous to the catalytic converter used on an automobile. The catalyst typically requires a minimum temperature for proper operation. When the grid requirements or dispatch require only minimum load, that level of operation may be restricted by the SCR. Effective minimum load to ensure a temperature adequate to maintain SCR performance may be higher than the load at which the plant would otherwise be able to operate safely and sustainably without the SCR. Industry and suppliers are dealing with some of these issues, with catalyst formulation and best methods of operation, but additional public/private sector collaboration to address this challenge would be useful, and DOE has an excellent track record for collaborative RD&D to develop emission control technology.

Additionally, the performance of FGDs added for SO₂ control, and potentially for oxidized mercury capture, may have been designed and tested at full load, but not optimized for transient (cycling) operation. Even if the FGD can meet emission requirements during these transients it may do so with higher parasitic power loads (e.g., pumping, pressure drop). In addition the quality and character of wastewater and solid byproduct streams from FGD such as gypsum may change during flexible operation. The solids and ions captured change depending on the specific process configurations and additives such as bromine used for mercury capture as well as coal constituents such as chlorine, boron, thallium, etc., which must be treated in the wastewater treatment process or managed in solid coal combustion products.

In addition to air pollution control requirements, water use also varies and plant water management may be disrupted by cycling operation. For example, a wet flue gas desulfurization - wastewater treatment (WFGD-WWT) system has a large volume of water/slurry stored within it. With any change in load, the water/slurry requirements change. Thus when a unit load is dropped there is less demand for water and the system has too much. The system operation adjusts to this but then the load demand is increased and now the system is short of water.

These swings in water demand result in operational and process upsets that the WFGD-WWT systems were not designed to handle. An industry-funded Water Research Center is being used to test novel technologies that assure compliance with regulations, promote efficiency and assure reliability under variable duty cycles.

National Coal Council – Reliable & Resilient: The Value of Our Existing Coal Fleet

Finally, generating units that are turned down (operated at reduced power output) below their original design basis may also see a reduction of mass transfer across the absorber, resulting in high emission levels. Cycles of concentration in the wastewater may be disrupted. This requires understanding of water balances in a variety of combinations of different coal types, plant designs, plant operating modes and control equipment configurations. DOE process modeling and simulation as well as industry R&D in this area in the past has been helpful.

In order to manage emissions controls, new operating practices need to be monitored, and instruments and controls must be matched to the variable load conditions during startup, shutdown and transient operation. Very low quantities of some trace elements are present in flue gases and waste waters. Yet to manage these they must be monitored, often in large streams, with corrosive constituents or erosive particles making proper monitors and instruments critical to operation. **Crosscutting efforts on monitoring of these constituents help not only existing coal units but new fossil and biomass units as well.**

Economic operation of existing coal units experiencing increased cycling in the future may require adjustments to traditional asset management approaches. The proper planning for use of system assets (asset management) is not simple and simple cost models do not always factor in issues like damage mechanisms from the difference between a hot unit restart and a warm or cold restart. Thermal and mechanical stresses on materials are not well known for operating conditions that have not been previously experienced. These stresses can lead to lower reliability and higher costs. For example, a series of fast startups from cold start conditions can cause header cracking, and very fast ramp can cause short term overheating and burst boiler tubes. These conditions could result in a lengthy outage and lost generation, yet the cost of this cycling impact may not be fully factored into dispatch cost algorithms.

On a system-wide basis the most flexible assets have an advantage in load balancing and providing system resiliency. New equipment changes, modifications, retirements and load requirements may make older operational correlations inaccurate and result in not understanding the longer term impacts of flexible operation. Gaining this information from case studies and unit analysis from a variety of coal and unit types can help the generating units and grid operate reliably, keep customer costs low and lead to efficient asset management and lower emissions. Revised operational insights and best practice analysis will help the existing plants manage operations to meet grid support demands.

It is well recognized that coal quality and character can impact reliability, emissions and efficiency, and aid in assuring flexibility. New concepts supported by DOE RD&D, such as coal drying, have already been adopted in limited commercial applications, but have potential for expanded use for efficiency gains, emission reduction and improved cold weather operability (e.g., frozen coal/coal feed management). Other processes for coal cleaning, trace element removal, etc., can be useful in combination with different emission controls to provide efficient operation and better control of emissions with flexible operation.

All of the above measures address issues relevant to a generating unit when it is operating. There are also issues that relate to units which are not operating. When a unit is brought down in load and then taken off line it is not always clear if that shutdown will be brief or extended. The management of gas and liquid side environments to prevent damage changes if an outage is

National Coal Council – Reliable & Resilient: The Value of Our Existing Coal Fleet

short or longer term, and gaining insights into best practices here will help the reliability of the fleet. With more units coming off line seasonally for extended layup it is now more common to consider measures to prevent materials degradation. A simple example is the addition of filming amines on the steam side in short term layup (e.g., over a weekend); yet if the layup is for a month the amines would be ineffective and more elaborate shutdown, inert blanketing and storage may be required. Additional measures may also be needed for worker safety, for purge and startup and it may be appropriate to modify system controls, logic and hardware to allow automated and routine longer term layup if this type of operation is anticipated in the future. The methods and costs of various layup options is another area of active R&D by industry and an ongoing need.

However, improved or upgraded instrumentation, sensors and software are ineffective if plant operators and maintenance staff do not understand their use. Ideas to improve flexibility and reduce impacts on the plant can be relatively simple, including things like control system modifications as new equipment is added or operation is adjusted. Training for these changing operating conditions is needed and resources to do training at multiple plant sites are not always available. Advanced simulation, remote O&M fleet wide monitoring and case study illustrations can be useful in training operating staff. Maintenance and repair training in proper welding techniques for aged or novel materials compared to original specification needs to be available. Training and operational aids are a research need.

Benefits from enabling existing coal-fired power plants to function reliably in the emerging marketplace should provide significant benefits to society. Coal units provide increased reliability and system resiliency during peak load periods as illustrated in the winters of 2012-13 and 2013-14. Regional constraints on natural gas transmission, coupled with high demand for heating and bottlenecks on gas supply particularly in the Northeastern U.S., have limited existing natural gas generation and caused short term price volatility and strained power generation capacity. Some reported short term prices were well over \$100/MMBtu for regional natural gas supply.⁹⁴

Coal has the unique advantage among central generation sources of an on-site coal pile providing weeks or even months of fuel supply at the point of generation, contributing to grid support reliability, resiliency and reduced regional fuel supply issues.

National Coal Council – Reliable & Resilient: The Value of Our Existing Coal Fleet

c. Findings

Load following and cycling of existing coal units is required now and will be required more and more in the future to provide resiliency for the grid. Increased unit cycling, with more frequent startups and shutdowns, and more operation at partial load present a number of challenges to the reliability, efficiency, environmental emissions and economical operation of the existing coal fleet.

- Fundamental understanding of advanced alloys, systems of materials and repairs can improve the reliability and resiliency of the fleet. More advanced and adaptable materials and improved welding, joining and repair methods (for thinner, stronger, more corrosion resistant, more flexible alloys and composites) can be used both for repair and for upgrades to existing plant. This can provide improved flexibility, reliability and more efficient operation.
- Improved instrumentation and control allows more flexibility, especially of recently installed more complex pollution control systems that have had unexpected operational issues (e.g., limits on operation, cross-pollutant impacts).
- Nondestructive evaluation methods and computational capabilities are inadequate for the more complex conditions and additional equipment found in today's operating plants. Improvements can help predict and help prevent failures and help operate and maintain equipment and retain flexibility.
- DOE has ongoing work on process control for next generation plants including first principles dynamic modeling, system and plant level simulation, algorithm development for sensor placement and addressing the complexity of advanced systems. This work could well be adapted to the more complex control requirements and new equipment needs from cycling and transient operation for the existing fleet.
- Better understanding of pollution control systems operating under cycling conditions is needed. During low load and at minimum load several systems can experience air, liquid and solid impacts such as the following: SCR can have issues with minimum load operation due to low temperatures making catalyst less effective for NOx reduction; FGD systems can have oxidation issues due to high excess oxygen in the flue gas that impact the form of captured selenium which makes water treatment for selenium difficult; and particulate emissions during startup and stabilization can change resistivity and chemical character of the particulate making particulate control difficult. The impact of newer additives used to enhance environmental systems, such as bromine added for mercury oxidation, can exacerbate corrosion issues and introduce new contaminants to wastewater streams. Additional research is also needed regarding cooling water consumption, and treatment of cooling water blowdown. The full extent of emission control needs is unknown because several significant regulations are still pending or in litigation.

National Coal Council – Reliable & Resilient: The Value of Our Existing Coal Fleet

d. Recommendations

- DOE should lead a collaborative effort with industry to develop improved assessment tools in several areas, including: damage mechanisms, costs and reliability changes associated with cycling and fuel changes; remaining life assessment for cycled units; and asset management tools.
- DOE should lead collaborative efforts in the areas of materials development (higher strength alloys allowing thinner components), fabrication (powdered metallurgy), welding techniques and evaluation of remaining life.
- DOE should lead collaborative efforts to develop improved sensors and control systems to automate flexible operation, detect maintenance issues associated with flexible operation, evaluate extreme environments and measure trace concentrations of toxic pollutants. Improved non-destructive evaluation techniques to test components should also be developed.
- DOE should lead collaborative efforts to develop improved “best practices” approaches to operating coal-fired power plants under cycling conditions and ramping conditions, including steam pressure management and maintaining proper water chemistry. Workforce training is needed in these new techniques.
- DOE should lead collaborative R&D regarding the impact of cycling and use of off-specification coals on environmental control systems, including cooling systems, SCRs operating at low load (improved catalysts), treatment of FGD effluent, wastewater treatment, landfill operation and leachate collection/treatment and HAPs controls.
- DOE should lead a collaborative effort with industry to investigate the potential for coal pre-treatment to improve operating flexibility and efficiency, as well as to reduce emissions.

National Coal Council – Reliable & Resilient: The Value of Our Existing Coal Fleet

3. Improving the Efficiency of Power Generation From the Existing Coal Fleet

a. Background and Introduction

Improving the efficiency of existing power plants is critical to maintaining the value of the existing coal fleet.

The operating paradigm of coal-fired plants has changed in the last few decades. Units designed for base load operation now routinely “cycle” between very low and high load. Boiler and environmental control system design was likely optimized for fuel properties that are constant but now are highly variable. Finally, the past practice of removing units from service for maintenance at 1-2 year intervals has been extended to 3 year or longer periods for many generating units. Each of these trends compromises plant generating efficiency.

Improving thermal efficiency can provide two important benefits: the reduction of fuel consumption, which lowers operating costs; and the reduction of emissions, including CO₂ emissions.^{xiii} Thermal efficiency improvements generally require an investment in process equipment, or in operation and maintenance (O&M), or more likely both. The economic incentive to improve efficiency at a power plant thus has practical limits. Most notably, the efficacy and payoff of any given efficiency improving measure at a power plant is site-specific. The improvements and payback described in this section are exemplary only, are not additive and depend on many factors. The initial design and condition of a plant, age, coal rank, environmental requirements and maintenance practices determine the payoff that can be derived. Benefits may be temporary as equipment wear asserts its toll.

Potential efficiency improvements at existing coal-fired power plants should be considered in the context of other future adjustments at these units. For example, operating at lower load will usually result in a higher heat rate, and lower load operation tends to occur with older units and units in systems heavily populated with intermittent renewable energy power plants.

Finally, regulatory considerations can complicate decisions to pursue energy efficiency projects. As discussed in Section C, efficiency improvements that reduce the variable cost of electricity generation can lead to increased use of a unit, and under certain conditions result in the changes being deemed a “major modification” for purposes of applying NSR regulations. In general, such a designation would entail significant new emission reduction requirements that would not only be costly, but that could offset and in some cases completely negate efficiency gains by increasing parasitic power demand to operate air pollution control equipment. For these reasons, such efficiency improving projects historically have not been implemented.

Appreciating efficiency improving opportunities addressed in different reports requires an understanding of terminology and conventions, including the following:

^{xiii} For a given unit and fuel, CO₂ emissions are directly proportional to heat rate, with a small adjustment for CO₂ release from systems using limestone FGD.

National Coal Council – Reliable & Resilient: The Value of Our Existing Coal Fleet

- Efficiency is the ratio of useful output energy divided by input energy. Efficiency is usually stated in terms of a percentage. The average efficiency of the U.S. coal fleet in 2012 was 33%.
- Heat Rate is the inverse of efficiency, i.e., input energy divided by useful output energy. In the U.S., heat rate is usually stated in British thermal units of input energy divided by kilowatt-hours of output energy (Btu/kWh). The average heat rate of the U.S. coal fleet in 2012 was 10,300 Btu/kWh (net). An increase in plant efficiency of one percentage point – from 33% to 34% – will reduce plant heat rate by approximately 300 Btu/kWh.
- Conventions Vary. The metrics by which both efficiency and heat rate are determined vary both between and within North America, Europe and China and Pacific Rim countries. Consistency and accuracy are critical. For example, heat rate can be stated in terms of “gross” power output (including the electricity consumed within the power plant for motors driving pumps, fans, pulverizers, etc.), or in terms of “net” power output (the electricity supplied to the grid). A pulverized coal power plant may consume 8% of its generation on-site, so a unit with a net heat rate of 10,300 Btu/kWh would operate at a gross heat rate of 9540 Btu/kWh (assuming 8% internal power consumption). Measurement conventions for input energy also vary. In North America, energy input is usually expressed based on a fuel’s higher heating value (HHV), which ignores certain energy losses associated with water in the products of combustion. In contrast, Europe uses the fuel’s lower heating value (LHV), which accounts for this unrecovered energy. The impact of this difference in conventions varies with the moisture content of the fuel. For a typical bituminous coal, the difference in reported efficiency is about 2% (i.e., 33% efficiency in the U.S. is equivalent to 35% in the U.K.). For higher moisture coals (subbituminous, lignite) the difference can be 3-5%.⁹⁵

The use of different efficiency metrics can be confusing. Some reports cite an efficiency improvement in terms of a specific component (e.g., 3% improvement in steam turbine efficiency) whereas others relate to the entire power plant (e.g., a 3% improvement in plant efficiency). It is critical – for DOE, the utility industry and EPA – to use the same basis for any comparisons. This report generally expresses performance improvements both in terms of a %-efficiency value and a heat rate value.

The remainder of Section D.3 describes potential efficiency improvements relevant to the existing coal fleet, summarizes key findings and recommends future actions by industry and the DOE to improve the efficiency of the existing coal fleet.

b. Analysis and Discussion

It is convenient to organize the discussion of efficiency improving opportunities around functionally similar categories within the power plant. Figure D.3.1 graphically depicts the major subsystems in a coal-fired power plant. Seven categories of plant activities or operational attributes are used in this report: (a) fuel type and fuel processing, (b) boiler and steam conditions, (c) steam path for energy extraction (e.g., steam turbine and ancillary components), (d) process controls, (e) options for low temperature heat recovery, (f) auxiliary power consumption and thermal losses, and (g) the cooling system. Each of these categories of design or operation will be examined as a means to improve thermal efficiency of generation. In

National Coal Council – Reliable & Resilient: The Value of Our Existing Coal Fleet

addition to this traditional view of efficiency improving options, this section will close with a brief discussion of possible approaches to changing the fundamental thermodynamics of an existing power plant via addition of “topping” or “bottoming” cycles.

Figure D.3.1. Power Plant Efficiency.

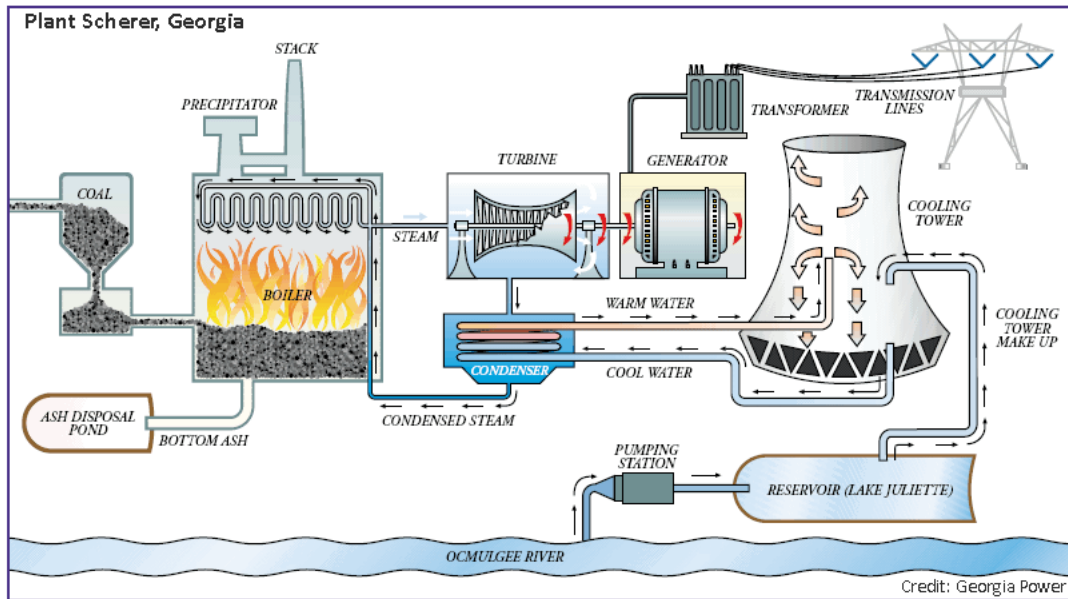

i. Fuel Type and Fuel Processing

Altering the source of coal or fuel mix can improve thermal efficiency. Fuels with lower moisture content have lower latent heat losses. Additionally, lower coal sulfur content reduces sulfur trioxide (SO_3) in flue gases. Flue gases must be maintained above the condensation temperature of SO_3 to avoid corrosion and plugging problems. Hence, lower sulfur coal may enable improved recovery of low quality heat.

There are three basic alternatives to changing coal characteristics: switch coals, dry the coal or process the coal.

Coal Switching. Coal properties determine both gross and net efficiency due to impacts on boiler performance and compatibility with environmental systems. Most coal switching in the last decade has substituted subbituminous for bituminous coal, seeking least cost SO_2 and NO_x compliance. Reversing these changes – if enabled by environmental control system design – could elevate efficiency due to the lower moisture content of higher rank coal. For example, a large (500 MW) generating unit that fires a bituminous coal, such as North Appalachian, and switched to Powder River Basin (PRB) subbituminous coal would incur a boiler thermal efficiency penalty of 4.2 percentage points (e.g., a boiler thermal efficiency of 89.2% would decrease to 85.0%, due to higher fuel moisture content). The auxiliary power consumption of pulverizers, gas fans and sootblowers could increase, in this example case, by 5.9%. As a result of the decrease in boiler efficiency and the increase in auxiliary power requirement, the net plant heat rate would

National Coal Council – Reliable & Resilient: The Value of Our Existing Coal Fleet

decrease by 5%, or about 500 Btu/kWh.⁹⁶ The thermal efficiency of generation would increase by about 1.6%. It is important to emphasize fuel choice is dictated by numerous variables (e.g., price, availability, boiler design and environmental controls) so changing coal rank may not be practical at many units.

Coal Drying. Lowering moisture from coal increases boiler thermal efficiency and thus plant generating thermal efficiency, if the moisture can be reduced using waste heat. Figure D.3.2 depicts the role of fuel moisture on total plant generating thermal efficiency, the latter calculated on both a HHV and LHV basis. Coal drying with waste heat is a commercially available option, but one that not every plant can effectively deploy. Drying coal with waste heat has been commercially deployed on North Dakota lignite to increase boiler thermal efficiency. Great River Energy utilized coal drying to reduce the moisture content of North Dakota lignite from 39% to 29%, increasing plant net generating thermal efficiency by 4% (lowering heat rate by about 1,200 Btu/kWh).⁹⁷ Less improvement would be expected for drying higher coal ranks (bituminous and subbituminous coals) because they tend to be much lower in moisture content than lignite.

Coal Processing. Altering the composition of coal – going beyond removing moisture – is defined as fuel processing or beneficiation. Payoff can be significant. Whereas conventional (physical) coal cleaning uses density as a basis for removing inorganic material, coal processing or beneficiation uses chemical treatment to reduce inorganic content. These processes focus on trace elements that can compromise material longevity and contribute to controlling regulated hazardous pollutants. For example, work conducted in the 1990s used binary and ternary supercritical fluids, and compounds such as perchloroethylene to remove sulfur and inorganic materials but was abandoned as flue gas desulfurization technology evolved.⁹⁸ Revisiting chemical coal treatment may provide significant payoff in improved efficiency, generation reliability and multi-pollutant control.

Additionally, coal beneficiation – adding compounds to coal during coal processing – shows promise. For example, PSEG is experimenting with an ammonium hydroxide-based beneficiation process that displaces both water and inorganic material. In a pilot test processing a “batch” of coal samples, coal moisture decreased from almost 31% to less than 7%. As a consequence, heating value increased from 7,859 Btu/lb to 11,363 Btu/lb.⁹⁹

Benefits of physically cleaned coal extend beyond efficiency improvement due to reduced moisture content. For example, removing inorganic material can reduce boiler slagging and fouling, improving heat transfer in the boiler and elevating efficiency. Lower sulfur fuel can reduce the auxiliary power demand for conventional FGD, increasing net unit power output.

Figure D.3.2. Coal Moisture Impact on Efficiency.

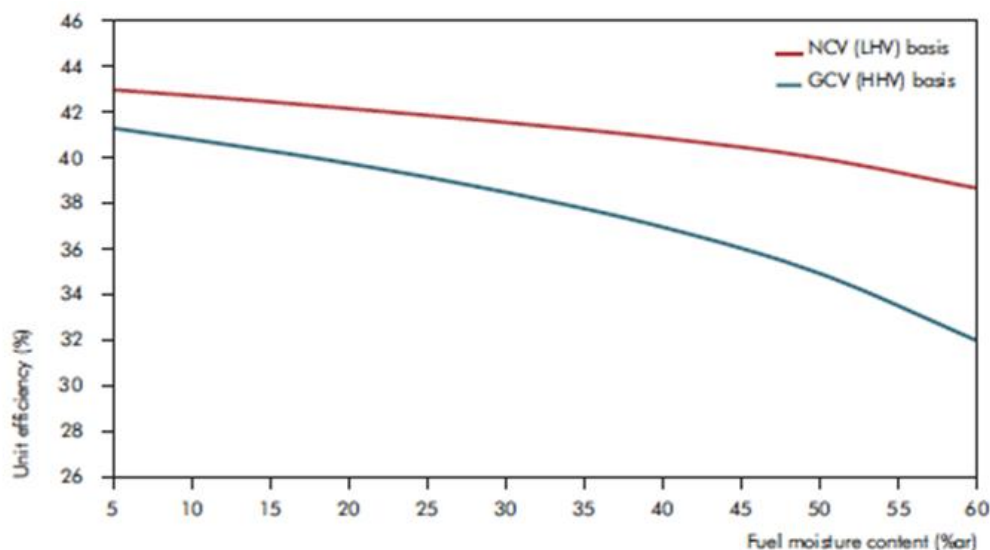

Figure courtesy of E.ON.

ii. Boiler and Steam Conditions

Several means are available to either restore boiler performance to original design levels, or improve on the original design based on unit-specific experience and improved materials.

Maximize Utilization of Existing Surface, or Add Surface. The utilization of existing boiler heat transfer surface area can sometimes be improved, depending on the existing state. Repairing or replacing failed or excessively fouled surfaces may improve boiler thermal efficiency and plant generating efficiency – although in many cases such improvements simply restore efficiency to original design values. Improving or restoring unit generating efficiency by up to 0.16-0.33 percentage points (lowering unit heat rate by up to about 50-100 Btu/kWh) is possible in exchange for capital costs of \$4-5M for a 500 MW plant.¹⁰⁰ For some units, heat transfer surface - such as the economizer section - can be increased, capturing more heat to preheat boiler feedwater. Some of these changes could enable greater flexibility in low load operation, such as extending the low load range for a unit’s selective catalytic reduction system. For example, upgraded economizers could reduce gas exit temperature by up to 20-40° F, increasing boiler thermal efficiency sufficiently to lower plant heat rate by up to 0.5-1% (i.e., increase generating efficiency by up to 0.16-0.33 percentage points).¹⁰¹

Advances in materials-of-construction – based on metallurgy and coating presently experimental and not yet commercially proven – could increase payoff. New materials can improve heat transfer, reduce accumulation of inorganic material and fouling, and lower pressure drop. One topic of interest is an evolving class of material coatings referred to as “nano-coatings” that minimize accumulation of deposits and thus resistance to heat removal from the tubes. In concept, the entire steam raising sections of a boiler can be replaced with advanced materials improving boiler efficiency and thus the thermal efficiency of generation.

National Coal Council – Reliable & Resilient: The Value of Our Existing Coal Fleet

Intelligent Sootblowing. Maintaining clean gas-side tube surfaces maximizes heat transfer for an operating cost mostly comprised of steam power to drive sootblowers. Activating sootblowers only when needed based on monitoring boiler performance is designated “intelligent” sootblowing and maintains clean tube surfaces with minimal power. On older boilers, gross heat rate reductions of up to 30-90 Btu/kWh (improvements in thermal efficiency of up to 0.1-0.3 percentage points) have been observed; improvements in thermal efficiency of up to 0.5 percentage points (heat rate reduction of up to 150 Btu/kWh) have been recorded for units firing PRB and lignite where slagging and fouling had reduced thermal efficiency. Typical efficiency improvements of up to 0.2 percentage points (heat rate reduction of up to 60 Btu/kWh) are anticipated. The capital cost for intelligent sootblowing is typically \$0.5M for a 500 MW plant.¹⁰² For example, the 780 MW Jeffrey Energy Center, firing subbituminous coal, installed intelligent sootblowing in conjunction with monitoring key areas of the furnace, such as measuring the accumulation of ash with strain gauges, and the thermal effectiveness of each heat exchanger in the boiler. Gross heat rate was lowered by about 90 Btu/kWh, increasing the thermal efficiency of generation by 0.3 percentage points.¹⁰³

In summary, extracting more heat from combustion gases could elevate by 0.5% the boiler efficiency (e.g., 88.0 to 88.5%) for each 10° F reduction in gas temperature. Increasing boiler temperature by this magnitude, where practical, will lower heat rate by 50 Btu/kWh, increasing thermal efficiency of generation by 0.17 percentage points. Almost all impacts on downstream equipment are beneficial, except for SCR NO_x control operation and increased potential for SO₃-derived deposits.

iii. Steam Turbine and Condenser

Changes to the steam turbine offer potential for significant improvement in power plant efficiency. These changes, which have been already implemented on many units, can include a complete replacement of rotors and inner casings, or upgrade of high-payoff components. For example, selected elements of the high-, intermediate- and low-pressure stages of a steam turbine can be replaced or refitted. Table D.3.1 summarizes the range in cost incurred and payoff derived for a menu of improvement options that are commercially available. As reported in Table D.3.1, for some units steam turbine efficiency gains can be achieved by installing improved or new control valves or seals, and the use of innovations such as partial arc admission for steam control valves, the latter enabling unit turndown with reduced loss of efficiency.

National Coal Council – Reliable & Resilient: The Value of Our Existing Coal Fleet

Table D.3.1. Summary of Cost, Heat Rate Payoff, and Capacity Payoff for Steam Turbine Improvement Options – For Circumstances Where a Technology is Practical.

Action	Capital Cost (\$M)	Heat Rate Payoff (Btu/kWh)	Capacity Payoff (%)
Steam Turbine General			
H ₂ Purity	0.25	10	0.10
Partial Arc Admission	1	50	0
Control Valves		4	
High Pressure Turbine			
Steam Seal Upgrade	1	50	0.75
Steam Path Upgrade	6	95-135	1.5
Intermediate Pressure Turbine			
Steam Seal Upgrade	1	20	0.20
Steam Path Upgrade	5	50-100	0.70
Low Pressure Turbine			
LP Steam Seal Upgrade	0.75	120	0.30
LP Steam Path Upgrade	5	65-225	0.65

Table D.3.1 shows replacing any of the high-, intermediate- or low-pressure components of the steam turbine will require a capital cost from \$1M for seals, \$5-6M for steam path changes, and from \$5 to \$8.5M for a rotor replacement. Gains in gross unit heat rate, for situations where these measures are practical, range from 30-40 Btu/kWh to several hundred Btu/kWh – representing an increase in generating efficiency of up to 0.10-0.67 percentage points. The large gains are possible only for units that are severely degraded. Retaining the turbine components but replacing ancillary components such as the steam valves, seals, and deploying partial arc admission provides a 5-50 Btu/kWh heat rate decrease – representing an increase in generating efficiency of up to 0.17 percentage points - for typically about \$1M capital cost.

The benefits listed in Table D.3.1 are believed typical, but the magnitude of any improvement and the cost to deploy vary significantly between different units. The specific payoff and cost vary from site to site. Advanced modeling with computational fluid dynamics (CFD) techniques is anticipated to identify improved designs and will increase these benefits.

The steam turbine condenser – cooled by either “once-through” means, or mechanical or natural draft towers – can be viewed as a complement to the steam turbine. (The specific role of cooling

National Coal Council – Reliable & Resilient: The Value of Our Existing Coal Fleet

towers is addressed in a subsequent section.) The condenser when properly cooled creates a partial vacuum that presents a “negative backpressure” to enhance turbine output. Hence, reduced condenser performance due to corroded surfaces or leakage reduces the condenser vacuum and turbine output (and plant efficiency). For example, allowing back pressure to increase from 40 to 60 mbar can increase the required heat consumption to provide the same power output by about 2.5%.¹⁰⁴

Figure D.3.3 depicts the role of condenser fouling on relative heat rate: poor cleaning of surfaces, resulting in a cleanliness factor of 75%, increases gross unit heat rate by 0.6 percentage points, or about 60 Btu/kWh, equivalent to a decrease in generating efficiency of 0.20 percentage points. Improved condenser maintenance can increase O&M costs by \$30-70K annually for a 500 MW unit, but elevate thermal efficiency by up to 0.10-0.25 percentage points, thus lowering gross unit heat rate by up to 30-70 Btu/kWh.¹⁰⁵

Figure D.3.3. Condenser Fouling and Turbine Heat Rate.

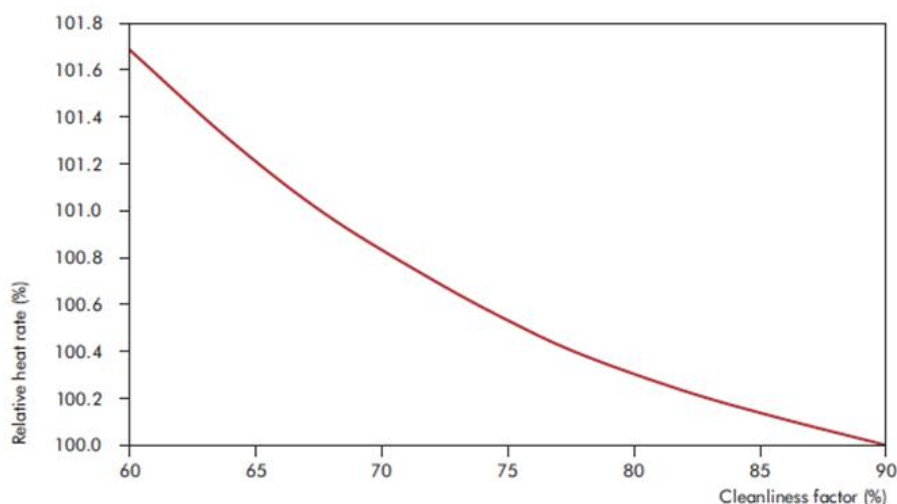

Source: © Australian Government Department of the Environment, reprinted with permission under a Creative Commons Attribution 3.0 Australia license (<http://creativecommons.org/licenses/by/3.0/au/deed.en>)

Periodically, condensers are “retubed” as tubes that are badly corroded and beyond repair are replaced with new material. This action is economic only for units high in capacity factor and with significant remaining lifetime, enabling recovery of investment.

Similar to the case with boiler heat exchangers, presently experimental advanced metallurgy and coatings could, with successful R&D, lead to improved condenser performance. These next-generation condensers could reduce corrosion and fouling, and enable expeditious and effective cleaning, thereby improving plant efficiency.

National Coal Council – Reliable & Resilient: The Value of Our Existing Coal Fleet

iv. Process Instrumentation and Controls

Both enhanced monitoring of plant condition – using advanced sensors and instrumentation as well as diagnostic software – offers significant payoff in plant efficiency.

The list of components and processes that can be monitored by advanced sensors and software is wide-ranging, and cuts across many aspects of plant operation. For example, the operation of fans, pulverizers, boiler feed pumps, steam turbine components, and the condition of the steam path, gas flow in ductwork and gas composition provide data that can be processed in real-time. Deploying neural network and other intelligent software to diagnose and control operation of these components – activating changes at the best time with respect to fuel utilization, boiler excess air and auxiliary power demand – favorably affects boiler thermal efficiency and plant auxiliary power consumption. Software products of this type are commercially available, but additional refinements could elevate benefits and payback.

The benefits vary widely, depending on the state of existing equipment, most importantly the digital signal processing capabilities. Heat rate improvements up to 150 Btu/kWh are possible.¹⁰⁶ The existing control system must be equipped with digital capabilities to maximize results, and in some cases the legacy control system must be upgraded. The capital charge for advanced process instrumentation and control systems – presuming an upgrade to digital controls is not required – typically ranges from \$0.50M to \$0.75M for a wide range of generating unit sizes.

Next-generation instrumentation and controls are being developed to both improve monitoring capability and address diagnostics. Specifically, developing Advanced Pattern Recognition software employs statistical methods to assist in the early identification and assessment of performance shortfalls. An array of sensors located throughout all major components of the power station – fuel preparation, the boiler, environmental controls, heat rejection equipment and the steam turbine – will report the status of key components in real time. Using this data and pattern recognition ability will further elevate insight to achieve high thermal efficiency.

The benefits of improved instrumentation and controls can be significant, with estimates showing a 5-to-1 payback in development costs in specific cases.¹⁰⁷

v. Low Temperature Heat Recovery

Several means to capture low quality heat can be explored to exploit further benefits, including:

Air Heater Performance. Air heaters are typically designed to lower average gas exit temperatures to within 5-10 °F of the SO₃ acid dewpoint. For most coals this temperature is between 280-320 °F. In practice a higher margin between the gas discharge temperature and the SO₃ dewpoint is typically observed to prevent localized corrosive damage to metal surfaces such as ductwork. In recent years, alkali-based sorbents have been used to remove SO₃, reducing acid gas emissions while minimizing the damaging role of SO₃. Injection of these alkaline compounds is not without risk; in some cases the solid sulfates produced will accumulate in the air heater, plugging gas passages (which harms efficiency). In some air heaters, it may be possible to increase heat exchanger surface area, assuming that there is sufficient fan power to overcome the additional pressure drop across the heat exchanger, and that SO₃ condensation is not a problem. Correction of leakage at air heater seals presents an additional opportunity to reduce heat losses.

National Coal Council – Reliable & Resilient: The Value of Our Existing Coal Fleet

Providing additional heat input to the boiler may introduce safety issues by creating an unstable condition in the pulverizers, perhaps resulting in spontaneous combustion of some low rank coals, but this issue is believed to be manageable.

Feedwater Preheating. Boiler feedwater is typically preheated with partially expanded steam from the steam turbine. Increasing the number of feedwater heating steps – typically 5-7 for state-of-art units – is feasible and uses readily available components and technology. The barriers to widespread implementation are cost for additional heat exchangers and increasing the capability of boiler feedwater pumps to overcome the additional resistance to flow. The effectiveness of feedwater heaters is impacted by both internal and external (water side and steam side) corrosion and deposits, and internal passages can become plugged and non-operative. Another means to increase feedwater heating is expanding the economizer section (which also preheats feedwater), as described in the previous section.

Supplemental Low Temperature Gas-Side Heat Recovery. Gas exiting the particulate collector prior to the FGD process contains low quality heat that with the right materials can be recovered. Heat exchanger design must account for corrosion and fouling. Near-term options are limited by heat exchanger cost and materials of construction. The history with low temperature heat recovery in the late 1970s and 1980s is not encouraging – gas/gas heat exchangers were deployed on units equipped with flue gas desulfurization to eliminate the heat rate penalty for flue gas reheat. These so-called gas reheaters were plagued with corrosion and high gas pressure drop. Most were removed in the mid-1990s as wet stacks were designed and installed to manage plume dispersion of wet flue gas. However if these problems could be overcome, the use of low temperature heat recovery for boiler feedwater preheat could increase plant generating thermal efficiency by up to 1%, thus lowering gross unit heat rate by up to about 300 Btu/kWh.¹⁰⁸

Technologies that cool flue gas and facilitate SO₃ condensation on fly ash, rather than on tube surfaces, can enable recovery of waste heat before the particulate control device.¹⁰⁹ These systems have been demonstrated in Japan with success over the last ten years. Some are constructed of simple carbon steel and could be retrofitted in an existing unit, particularly if a unit is undergoing a hot to cold side particulate control device conversion.

vi. Auxiliary Power Consumption

The net plant thermal efficiency is directly affected by the consumption of auxiliary power for ancillary components. Several means are available by which to minimize auxiliary power losses. Variable speed drives (VSD) can minimize power consumption at lower load, and can be applied to large power consuming motors for induced draft and forced draft gas fans, circulating water pumps, coal pulverizers, flue gas desulfurization alkali slurry pumps, cooling tower fans and other major power consuming motors. These motors and drives can consume almost all of the typically 8% of gross plant load devoted to auxiliary power.¹¹⁰

Variable frequency drives are commercially available. For existing units that are shifted from base load to cycling duty these systems may have increased value in reducing the associated heat rate degradation. The capital cost for such equipment is \$9-11M for a 500 MW plant, with the range of net thermal efficiency increasing by up to 0.05-0.50 percentage points (e.g., lowering heat rate

National Coal Council – Reliable & Resilient: The Value of Our Existing Coal Fleet

as much as 15-150 Btu/kWh). The wide range in improvement is due to the variable baseline, defined by the drive motors the plant was equipped with.¹¹¹

Other methods can reduce auxiliary power losses but the applicability can be limited and payoff uncertain. Specifically, advanced CFD techniques can be applied to streamline the entire combustion air and combustion product gas flow path, reducing power consumption by fans by as much as 15% - 25% (depending on the unit).¹¹² Reducing air infiltration into the boiler ductwork where applicable can increase gas temperature aiding heat recovery and improve boiler efficiency by up to 0.15 percentage points (lowering gross plant heat rate by as much as 15 Btu/kWh), and reduce fan power consumption. These measures to reduce auxiliary power are commercial but the modest payoff – typically increasing the thermal generation efficiency by no more than 0.05 percentage points – has limited application.

vii. Cooling System

Recirculating cooling systems (cooling towers) are most efficient when there is optimal distribution of cooling water flow across the tower “pack” – the sections that promote evaporative cooling. Improving the distribution of water improves performance. Replacing or augmenting the “pack” with improved materials to promote evaporative cooling increases cooling tower performance, increasing thermal efficiency of generation by up to 0.26 percentage points (reduction in gross heat rate of up to 70 Btu/kWh). These benefits are mostly applicable in summer months. The cost can range from \$1.5 to 5 M for a 500 MW plant. In theory, augmenting cooling with a supplementary “helper” tower can also improve performance, if space on-site is available.

The potential increase in thermal efficiency from a “helper” tower is site-specific and requires a detailed site study. The other approach to heat rejection at a power plant is “once-through” cooling, which withdraws water from a water body, uses it for cooling in the condenser and returns it to the water body at an elevated temperature. Actions to increase heat transfer by maintaining clean condenser surfaces are of greatest interest for this type of cooling system.

Options to improve cooling are uncertain due to pending regulations impacting once-through cooling at existing power plants (i.e., Clean Water Act section 316(b) rules). In most cases, the use of once-through cooling removes more heat from the condenser compared to cooling towers, particularly if a relatively low temperature source of cooling water is obtained, such as from a large river or lake. If Section 316(b) rules prohibit using once-through cooling and require converting to cooling towers, the reduced condenser heat removal will lower generating efficiency.

viii. Changing Plant Thermodynamics

The efficiency-increasing measures addressed in this report so far target conventional plant design - the industry “workhorse” deployed to date. These concepts have been applied at one or more plants, with variable payoff. These measures serve to refine and optimize plant operation, but the performance does not significantly change because the thermodynamics of plant design remain essentially the same.

More radical steps can be explored to extend the thermodynamic limits to gain efficiency. These actions enable the single Rankine cycle that typifies a conventional plant to either exploit higher

National Coal Council – Reliable & Resilient: The Value of Our Existing Coal Fleet

temperature heat addition, or to reject heat at lower temperatures. To accomplish this the thermodynamic cycle would be changed by adding a separate “topping” step or a “bottoming” step to the conventional Rankine cycle.

Other more radical changes to the thermodynamic cycle have been used in the past. Specifically, an existing Rankine cycle can be coupled with a “bottoming” step using the Brayton cycle. This well-known “combined cycle” approach is broadly deployed for natural gas-firing and is a state-of-art concept for advanced coal-based generation. However, retrofitting such a combined cycle to an existing unit can be of limited value. The retrofit of combined cycle has been successfully implemented on a generating unit at the Wabash River station, but provided limited payback. Consequently, this discussion focuses on elevating the temperature of Rankine cycle heat addition and improving heat rejection.

It should be noted that retrofit constraints could prohibit changes to the thermodynamic cycle. These constraints include limited space for the additional heat exchangers, modifications to the gas and steam path, and the need for refined process instrumentation and controls. It is likely that retrofitting high temperature heat exchangers on an existing boiler will require “dissimilar” metal junctions. Technical challenges related to dissimilar metal welds and other factors must be addressed.

Topping Cycle Addition. A topping cycle can be added, either increasing the temperature of heat added to the Rankine cycle, or alternatively as a separate closed loop Brayton cycle. Exploiting the Rankine cycle is likely the closer to near-term availability of the two options.

A Rankine topping cycle would first provide a means to capture high temperature boiler heat, and then extract useful work with a second, separate steam turbine. (See Figure D.3.4.) This action – effectively empowering a subcritical steam boiler to provide supercritical or ultra-supercritical steam conditions – elevate the generation efficiency by up to 2-4 percentage points, thereby lowering gross heat rate by as much as 600-1,200 Btu/kWh.¹¹³ The hardware to deploy such a system using steam as the working media could be developed within 10 years. Other working media with potentially more favorable thermodynamic properties, such as ammonia or supercritical CO₂, could be applied to further improve efficiency, but this effort would likely require more than 10 years of development, to assure material and media compatibility.

Figure D.3.4 depicts one means to deploy a Rankine-based topping cycle. In the conventional layout, the boiler generates steam for expansion in the high pressure (H-P) turbine, which exhausts the expanded steam to the boiler for reheat, that is in turn expanded in the intermediate pressure (I-P) turbine. The expanded steam from the intermediate-stage turbine enters the low pressure (L-P) turbine which operates in the conventional manner. A topping cycle would entail retrofitting heat exchangers constructed of material that can deliver supercritical or ultra-supercritical steam pressure and temperature, to be expanded in a supercritical (SC) steam turbine designed for these conditions.

Figure D.3.4. Schematic of Topping Cycle for Conventional Rankine Power Station.

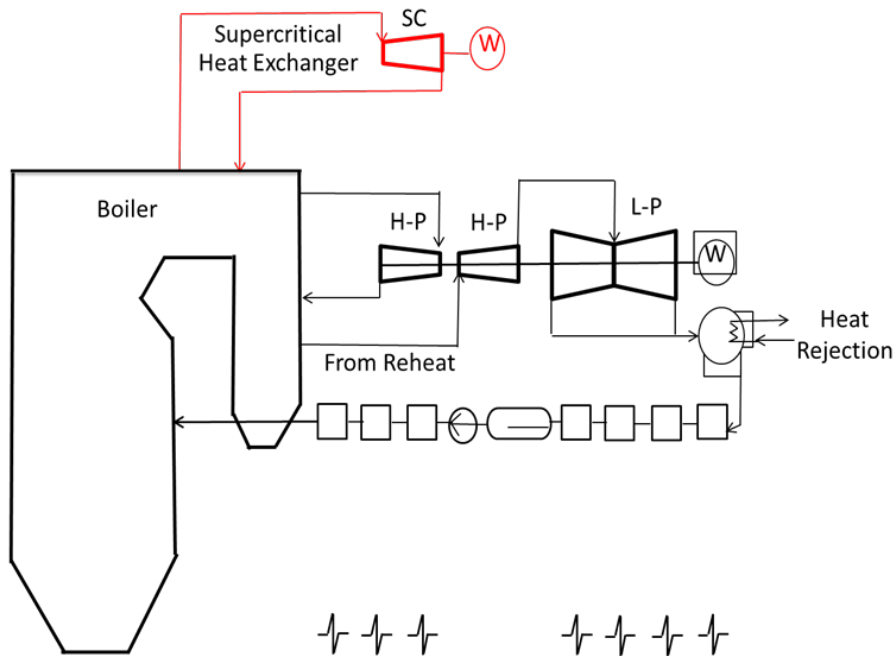

A Rankine topping cycle that could employ advanced ultra-supercritical (AUSC) steam conditions – up to 1,120° F steam temperature – could be developed in a ten-year effort. A longer term pathway – perhaps 15 years – could deliver steam temperatures up to 1400° F, further increasing efficiency.

A second topping cycle option is the closed Brayton cycle using CO₂ as a working fluid. The closed Brayton cycle – used in nuclear power generation – will require a longer development period compared to a Rankine topping cycle. This topping cycle theoretically could be retrofit into a conventional plant in a manner similar to the topping Rankine cycle in Figure D.3.4, except that a second cooling system would be required. Similar to the topping Rankine cycle, an additional heat exchanger is retrofit into the boiler to generate a high pressure and temperature working media – perhaps supercritical CO₂ (due to attractive thermodynamic properties). The high pressure, high temperature CO₂ expands in a closed cycle turbine, enabled by cooling from a second cooling system (wet or dry tower or heat exchanger). Depending on the working media and the details of the cycle, the increase in efficiency could exceed that of a Rankine-based topping cycle. This option is believed to be competitive with elevating the Rankine cycle temperature addition in cost and performance. The benefits could be significant and as such this options merits development.

As noted in the beginning of this section, retrofit barriers to extension of the thermodynamic cycle could be significant. These barriers would have to be explored in design studies to identify solutions.

National Coal Council – Reliable & Resilient: The Value of Our Existing Coal Fleet

Bottoming Cycles. Rankine bottoming cycles can improve heat rejection and thus increase thermal efficiency. The concept of using a bottoming cycle is not new, and has been successfully applied in small industrial processes as a means to utilize waste heat.¹¹⁴ A Rankine bottoming cycle would replace the conventional steam condenser with an alternative heat exchanger that operated in a closed cycle cooling system. An alternative working media such as an organic fluid, ammonia (NH₃), or CO₂ could be used that can be more effective than steam. A bottoming cycle option that would employ an organic solvent is possible in the longer term, and could improve thermal efficiency by 1 percentage point or less, lowering gross plant heat rate by as much as 300 Btu/kWh, but perhaps more importantly eliminate the use of water for cooling.

ix. Cumulative Benefits of Multiple Actions

Many of the preceding actions can be applied contemporaneously to derive multiple benefits, assuming that the conditions at the target unit are favorable to the changes. In some cases the benefits are cumulative – such as those derived from minimizing auxiliary power, fuel drying, and improving heat rejection. Other actions that increase heat removal from the boiler – economizer modifications, improved air heater performance and low temperature heat recovery – do not provide cumulative benefits. All efficiency improving measures are unit and site-specific and will not always be technically and/or economically feasible.

Regardless, near-term efficiency gains can accrue from several actions at a unit. As an example, consider a nominal 500 MW unit that is fully equipped with state-of-art environmental controls, and located in a Midwestern state where the penetration of wind power is significant, thus forcing the unit to lower capacity factors and “deeper” levels of cycling. As a result, the operating time spent at low load where economizer temperatures are below the minimum required for effective SCR operation is significant, leading to higher NO_x emissions.

Several near-term actions could improve low load performance and increase heat recovery at this hypothetical unit. First, a split economizer could be deployed, capturing additional heat following the SCR process. This additional heat is used for boiler feedwater preheat. Next, a revised air heater is utilized enabling extremely low air heater temperatures – to perhaps 240° F. Key to achieving this level of heat recovery is the near elimination of SO₃ by alkali injection, and designing heat absorbing materials to avoid accumulating deposits. It should be noted that it has not yet been demonstrated that an air heater exit gas temperature as low as 240° F can be practically achieved, but future efforts may show this outcome is feasible. An additional efficiency-improving step in this example is deploying fuel drying to lower moisture from coal – in this case a low sulfur eastern fuel – to further increase boiler efficiency. Finally, installing a new condenser constructed from state-of-art materials that resist fouling will improve heat rejection and efficiency.

A detailed analysis would be required to assess the benefits of this set of measures, as well as its compatibility with new source review regulations. It is possible that a thermal efficiency improvement of up to 3-4 percentage points could be derived, if these actions can be proven to work together and do not compromise plant reliability.

National Coal Council – Reliable & Resilient: The Value of Our Existing Coal Fleet

x. Important Caveats

Projects to improve the efficiency of existing coal-fired power plants are considered in the context of site-specific technical and economic considerations. Although the individual technologies can be described in general terms, their likely degree of deployment in the coal fleet cannot be. Conditions excluding a potentially applicable technology might include:

- The hardware present at a unit. For example, an option designed for a Ljungstrom air preheater may not apply to a unit using a tubular air preheater.
- The measure may have already been employed.
- The measure may present operational or reliability issues that outweigh its value in efficiency gains.
- The cost of the change may exceed its value in efficiency improvement.
- The change may raise NSR “major modification” issues.
- Efficiency improvements from some types of measures will degrade over time.

There are also factors at play which could lead to decreased efficiency at existing coal-fired power plants. These include:

- Operation at reduced load, which generally increases a unit’s heat rate. Reduced load might result from expanded renewable energy or natural gas-based generation, or higher variable costs at an aging unit. For example, changing a subcritical unit from full load to 50% load can increase heat rate by 900 Btu/kWh, imposing a penalty in thermal generation efficiency of 3% for the period of operation at 50% load.¹¹⁵
- Variable load operation. Startups and periods of transitional operation increase heat rate, so more variable unit operation tends to lead to higher overall heat rate.
- Adding environmental controls. Parasitic power requirements for a wet scrubber can reduce net output and increase net heat rate by 2-3%, lowering net thermal efficiency of generation by 0.65-1.0 percentage point. Converting the cooling system from once-through to recirculating cooling (cooling towers) can reduce thermal efficiency of generation by 0.5 percentage points (increase heat rates by 1.5%).¹¹⁶
- Switching from bituminous coal to a high moisture subbituminous coal could increase heat rates significantly, both due to the moisture and due to higher power requirements for pulverizers.

National Coal Council – Reliable & Resilient: The Value of Our Existing Coal Fleet

c. Findings

- A number of efficiency improving measures are commercially available for use with the existing fleet. The benefits and cost are highly variable and depend on the specifics of any one site. Many of these measures have been already applied on units in the existing inventory. Additional work is necessary to determine how to increase the penetration of these measures across the generating fleet, and the magnitude of the benefits.
- Of the options commercially available, two significant opportunities to increase efficiency include steam turbine upgrades (such as rotor replacements), and measures to reduce the moisture of lower rank coals using waste heat, although, again, it must be emphasized that the magnitude and availability of these opportunities are highly site-specific. Continued work to refine turbine blade design, and the use of advanced materials could lead to further opportunities. Additional benefits, as yet unquantified, are believed to be achievable in the next ten years.
- Significant opportunities to increase efficiency are also available by improving heat rejection through the condenser, as aided by design changes to cooling towers and once-through cooling systems. Improved materials may reduce fouling of condenser surfaces and improve performance, while improved cooling tower designs and materials may increase heat rejection.
- There are areas where additional incremental RD&D is appropriate, such as revisiting the benefits of chemical coal cleaning, developing improved materials, coatings for boiler tubes and next-generation sensors and controls that incorporate diagnostic capabilities. Better monitoring and control can potentially benefit both part load and full load heat rates.
- Low temperature heat recovery shows promise, but needs work. Corrosion issues in concept can be reduced by alkali injection, but heat exchangers that resist corrosion/fouling and present low gas pressure drop must be developed. Such heat exchangers may be enabled by new coatings (nano-coatings; super hydrophobic coatings) to improve heat transfer properties. Alternatively, it may be possible to utilize simple carbon steel in heat exchangers that resist corrosion through the interaction of ash and SO₃. These low temperature heat recovery concepts provide an added benefit of reducing trace metals and SO₃ in air emissions by improving the performance of particulate controls via lower flue gas temperatures.
- Enhancing the conventional Rankine Thermodynamic cycle by adding topping or bottoming cycles, or using different working fluids than water, show promise for significant efficiency improvements. These options require significant cost and major changes to the generating unit and control systems. Rankine bottoming cycles using organic fluids have been deployed with success on small industrial processes as a means to utilize waste heat. The retrofitting of bottoming or topping cycles (with one exception) has not been deployed to date, and would require RD&D to become commercially viable.
- Achieving the most significant improvements in efficiency may be deterred by concern that the required equipment modifications and improvements will be characterized a “major modification” under New Source Review regulations, and result in additional environmental requirements that would be costly and reduce the efficiency gains.

National Coal Council – Reliable & Resilient: The Value of Our Existing Coal Fleet

d. Recommendations

- The private sector should work to develop improved fuel drying heat exchangers for use with high moisture fuels, such as PRB subbituminous coal and lignite.
- The private sector should continue work to develop tube coatings to enhance heat transfer, use alkali injection to reduce SO₃ in flue gas and enable greater heat recovery from air heaters, develop non-metallic heat exchangers for recovering low temperature heat, and extend neural network technologies into next-generation sensors and software. An R&D campaign needs to be undertaken to demonstrate the effectiveness and reliability of deploying these actions into commercial plants.
- DOE should lead a collaborative effort with industry to design next-generation steam condensers, using state-of-art materials that resist fouling and corrosion; develop advanced, enhanced heat transfer materials and material coatings; develop improved cooling tower pack materials; and revisit chemical coal cleaning processes developed in the 1980s (in light of multiple benefits to efficiency, reliability, and emission control).
- DOE should lead a long-term (10 year) collaborative effort with industry to integrate topping and bottoming cycles with existing power plant designs in order to substantially increase the efficiency of existing power plants.
- DOE should work with EPA to find a way to deploy changes at existing coal-fired power plants that would result in higher fleet efficiency, including adding heat exchanger surface in the boiler, improving steam paths, providing better heat rejection, and in the long-term the use of topping and bottoming cycles, without imposing new emission reduction requirements due to the change.

4. Emission Reductions from the Existing Fleet

a. Addressing Conventional Pollutants

i. Background and Introduction

For purposes of this report, the term “Conventional Pollutants” refers to all regulated air, water and solid waste products from an existing coal-fueled power plant, other than CO₂.

With respect to conventional pollutants, this report will focus on the impact of recent regulations, or pending regulations that require emission controls that differ from previous regulations. For example, new systems to mitigate mercury emissions into the atmosphere may result in trace materials being introduced into the flue gas of an existing coal-fueled power plant, and into other emission control systems, where the trace materials could become a wastewater issue.

Some of the new regulations require compliance in a very short time frame. For example, the compliance deadline for MATS is generally 2016. For these rules, there is insufficient time to launch an R&D program to address compliance issues. Other rules are still pending and may provide the needed time for useful RD&D. In short, the following discussion is not a general analysis of all pollution control measures applicable to the existing fleet. Rather, it focuses on relatively recent regulatory developments, for which RD&D may result in more effective or more cost-effective mitigation technologies.

The National Carbon Capture Center

The National Carbon Capture Center (NCCC) is a key component of the DOE’s strategy in promoting U.S. economic, environmental and energy security through reliable, clean and affordable power produced from coal. The NCCC is a cost-effective, flexible test center for evaluating the critical components of advanced CO₂ capture and power generation technologies which are crucial for maintaining coal as a viable fuel source. The center was established in 2009. Offering a world-class neutral test facility, providing access to real flue gas and syngas streams, with utilities, steam and instrumentation provided, and employing a highly specialized staff, the NCCC accelerates the commercialization of advanced technologies to enable coal-based power plants to achieve near-zero emissions. In undertaking its mission, the NCCC is involved in a range of activities to develop the most promising technologies for future commercial deployment, thereby maximizing the value derived from project funds.



The existing coal fleet will require new and improved technologies to meet ever changing environmental requirements for non-carbon emissions. The NCCC concept – providing an accessible (and reusable) test bed for technologies that are ready for evaluation in a genuine power plant operating environment – is an excellent and cost effective approach to ensure that emerging technologies are evaluated, refined and commercialized as rapidly as possible.

ii. Analysis and Discussion

Air Emissions

Many of the emission control technologies being installed today on the existing coal fleet were accelerated in their development process by DOE supported RD&D programs. This is certainly true for SO_x, NO_x, particulate control and more recently mercury and HAPs control. Both R&D, pilot plant tests and first of a kind demonstration programs were supported by DOE and enabled by prior clean coal programs, including the Power Plant Improvement Initiative and Clean Coal Power Initiative. Since the DOE Innovation for Existing Plants program concluded and work on mercury large scale field tests was completed, new RD&D issues have surfaced as technology is being applied.

The key culprit is the continual addition of disparate emission requirements on existing plants, and the subsequent interactions of new emission controls. Operating problems have become more acute – the need for flexible operation and “deep” turndown. Control technologies

National Coal Council – Reliable & Resilient: The Value of Our Existing Coal Fleet

developed some years ago have experienced unanticipated problems, such as cross media impacts on wastewater streams or solids. Process reactors for the selective catalytic reduction of NO_x incur buildups of compounds like ammonium bisulfate when operated near the minimum operating temperature, as required for NO_x control at low load. The resulting limits on operation were discussed earlier. Understanding the materials of construction issues is an example of new R&D that is a consequence of proposed emissions control additives. This requires sophisticated measurement, monitoring and control as well as specific water treatment and enhanced materials use. DOE R&D that is ongoing on materials, instrumentation and controls, and sensors as well as work now re-starting on water management can benefit the management of conventional air emissions.

Water Emissions

With new requirements for individual wastewater treatment proposed by regulators, existing plants may require separate water treatment of many disparate streams rather than treatment of single combined streams like ash pond effluent. Regulation of new constituents (e.g., wash waters from new environmental equipment, cooling tower blowdown experiencing higher concentrations from increased cycles of concentration, etc.) may require multiple wastewater treatment options at a single plant with different methods. DOE support, building on prior work in water and HAPs control, could be helpful.

Solid Waste Emissions

Solid waste streams (also termed coal combustion products and coal combustion residuals) are also changing as new devices and process integration are added to meet new regulatory requirements. Where fly ash may have been sold for cement or concrete additive, addition of solids can put the ash out of specification for such use. In addition, new water balances and WFGD use with new air emission controls may cause new issues for products like gypsum. The ultimate product from a zero discharge water unit, if that is used, is a salt that requires management as a solid.

EPA has proposed but not yet promulgated final rules for management of coal combustion residuals (CCRs). One challenge facing owners of coal generating facilities is ensuring containment of wastes in existing impoundments. It may be useful to explore the economic feasibility of reevaluating the potential to extract stored ash for beneficial use and converting these impoundments to dry storage.

In short, it all goes somewhere and the new integrated management aspects of air, water and solids all interact. Improved knowledge of these interactions is needed and would benefit from expanded DOE support.

National Coal Council – Reliable & Resilient: The Value of Our Existing Coal Fleet

iii. Findings

- New emission streams are being generated by the systems employed to capture traditional hazardous air pollutants. The contaminants can present challenges both to emission control and corrosion control of downstream equipment.
- Trace contaminants in solid waste streams can interfere with the ability to recycle collected materials for beneficial use.
- Given relatively short compliance periods, little time is available to develop new approaches to address these issues.

iv. Recommendations

- DOE should reestablish a program for Innovations for Existing Plants. Identification of specific technologies to be developed can be established via NETL-sponsored workshops to take input on the most pressing technology needs.
- DOE should consider the limited time period available before commercial systems are needed for compliance in determining the best funding approach for this effort.

b. Retrofitting CCS on the Existing Coal Fleet

i. Background and Introduction

On November 25, 2009, the White House announced that the President's climate goal for 2050 was an 83% reduction in U.S. GHG emissions, relative to 2005 levels.¹¹⁷ Fossil energy-based electricity generation contributed 31% of total U.S. GHG emissions in 2012 (23% from coal-fired units; 8% from natural gas-fired units).¹¹⁸ These numbers suggest a need for a large reduction in CO₂ emissions from fossil energy-based power generation over the coming decades. One possible pathway for such a reduction is the development and deployment of CCS technologies. The DOE has been pursuing a program of RD&D on CCS technologies for over a decade. Congress has appropriated \$5.7 billion for this program since FY2008.¹¹⁹ For comparison, consider federal funds directed toward other low-carbon programs. In FY2013 (only), Congress appropriated \$3.9 billion for energy efficiency and renewable energy incentive programs.¹²⁰ This total excludes Internal Revenue Service tax credits, such as the additional \$3.9 billion paid as a production tax credit to qualifying wind generators for 2013.¹²¹

This Section will address the status of CCS technology and identify areas where additional effort is needed. As the details of the CCS options have been discussed in previous NCC reports,¹²² that material will not be repeated here; highlights of key CCS options and a summary of demonstration projects are presented in the text. Appendix B provides additional information on the demonstration projects planned and in progress.

ii. Analysis and Discussion

The Scope of the Challenge

The challenge for CCS is broad. The variety of applications presented by three ranks of coal (bituminous, subbituminous and lignite) and four firing systems (pulverized coal, crushed coal with cyclones, fluid bed and integrated gasification/combined cycle) are numerous. The evolving

National Coal Council – Reliable & Resilient: The Value of Our Existing Coal Fleet

coal-firing technique of oxycombustion is also a candidate to use for retrofit or repower if plant owners need to apply CCS.^{xiv}

CO₂ separation techniques can employ chemical sorbents, membranes, physical sorbents and other techniques. CO₂ storage is envisioned in both deep saline reservoirs, as well as in oil bearing formations for EOR. Suitability of storage reservoirs within each of these categories can vary significantly in terms of location, porosity, permeability and other characteristics critical to the ability of the targeted storage space to permanently contain injected CO₂.

A program to commercialize CCS will not have to address every permutation of fuel, combustion technique, capture technique and storage approach. It is clear however that a successful CCS development program will require multiple commercial scale demonstrations. The requirements for a demonstration program to address the risks of evolving CCS are discussed below.

Mitigating Elements of Technology Risk

The evolution of CCS – by far the most complex environmental control process conceived and proposed to date – will present risk to host generating units.

Owners of evolving environmental control technology distinguish between a process being commercially offered as opposed to commercially proven. Typically, a technology is considered commercially offered if a supplier can design, construct and startup a control process. This product can be state-of-the-art, employ best design practices, but due to limited experience performance cannot be guaranteed.¹²³

In contrast, a control technology is considered commercially proven if a supplier has meaningful commercial experience, and the supplier can offer performance guarantees so that risk is commensurate with other aspects of power generation equipment. The evolution of a process from the state of commercially offered to commercially proven requires gaining meaningful experience at large scale, with a variety of coals, and meeting reliability targets. The evolutionary steps are addressed as follows:

Scale. A typical existing coal-fired power plant likely to consider retrofit of CCS will generate 400-800 MW – requiring treatment of combustion products at large scale. Evolving technologies are necessarily tested at small-scale, and – if passing threshold tests – evolve to slip-stream tests, small commercial unit tests, and eventually 300-400 MW commercial demonstrations. A step-by-step scale-up is required so lessons learned at pilot-plant and 50-100 MW scale can be extended to commercially competitive units.

Coal Variety. Experience should be available with three categories (or ranks) of coal in the U.S. – bituminous, subbituminous, and lignite – for a process to be commercially proven and suitable for national application. The influence of coal type ranges from the gas volume generated to the content of trace species. The trace species content has implications for material corrosion,

^{xiv} For example, FutureGen2 will repower an existing pulverized coal unit with oxycombustion and CCS.

National Coal Council – Reliable & Resilient: The Value of Our Existing Coal Fleet

performance of catalysts and reagent injected for pollutant removal, and composition of liquid and solid byproducts.

Reliability. The most damaging aspect of poor reliability is not failure to meet a specified environmental control target – but forcing the host unit to operate either at restricted load, or to shut down for maintenance and repairs. The cost penalty incurred is dominated by lost revenue from the plant, rather than labor or parts for repair or enhanced maintenance. Additionally, units failing to meet commitments to regional transmission organizations can face steep fines.

Meaningful Process Guarantees. The owner should be protected from most reasonable risks due to failure of a process to attain guaranteed environmental control targets, or compromised reliability. Power station owners can never be fully protected from process failure – the cost to a supplier to compensate an owner for lost revenue is too great to insure. However, suppliers can guarantee the numerous subsystems of process performance – gas pressure drop across an absorber, lifetime of a catalyst or the degree of utilization of reagent, and material longevity, as examples. Suppliers will not be able to guarantee these aspects of a process without extensive experience at the scale and variety of fuel types the market requires.

Lessons from Flue Gas Desulfurization

The experience in commercializing flue gas desulfurization is instructive in the evolution of CCS.

Technologies to remove SO₂ from the flue gas of conventional pulverized coal emerged in the early 1970s, and required three decades of testing at scale to evolve the technology so as to offer meaningful process guarantees.

Present-day flue gas desulfurization processes deliver up to 98% SO₂ removal, do not compromise plant reliability and minimally penalize plant thermal efficiency. This was not always the case. Early FGD equipment compromised plant reliability and frequently did not meet SO₂ removal requirements. The problem was so acute that the EPA for many years routinely tracked the SO₂ removal and reliability penalty imposed by FGD equipment.¹²⁴ For example, FGD-equipped plants in 1978 that fired high sulfur and medium sulfur content coal averaged reliability levels of 53 and 69%, respectively, well below acceptable levels.¹²⁵

Decades of evolving processes, refining process chemistry and using experience to improve equipment design essentially eliminated the reliability penalty.

The Need for Process Integration

Operating CCS will be disruptive to a coal-fired power plant. The present state of CCS capture processes require substantial power and compromise a unit's electrical output. The magnitude of power loss and heat rate compromise is demonstrated by the decision of owners of the W.A. Parish station, to add an 80 MW natural gas turbine to power the CO₂ compressors and solvent generators for a CCS demonstration unit, rather than absorb the generation loss. Moreover, the CO₂ capture and processing rate must be integrated with the pipeline delivery of CO₂ to its storage site and the storage injection process. All of these components must work together; otherwise one component limits the operation and reliability of whole system.

National Coal Council – Reliable & Resilient: The Value of Our Existing Coal Fleet

Many of the components that comprise a CO₂ capture process have been demonstrated in other duty, but to date as separate elements. As demonstrated with FGD evolution, a control technology can be affordable and reliable only with multiple applications that show how to integrate the components.¹²⁶

Controls, Load Following. A large number of individual components must operate in a synchronous manner through load swings, and not present limits to ramp-up or ramp-down rate, or induce performance shortfalls for environmental controls.

Effective Use of Low Quality Heat (Thermal Efficiency). The significant heat rate penalty that accompanies CCS could be mitigated by integrating the use of low quality heat in the plant.

Retrofit Specific Issues

There are several aspects of retrofit CCS applications that differ substantially from greenfield (new facility) applications. These include:

- The age and remaining life of the existing unit being retrofit
- Limitations on physical space at the existing facility, and the proximity of major components
- Limited sources of auxiliary power to operate the CCS system
- Proximity to CO₂ storage sites or pipelines

Ultimately, a decision to retrofit CCS will be complex and involve impacts on the overall generating system, dispatching economics, return on investment, the timing of the retrofit, future fuel price volatility and other factors. CCS retrofit projects that include replacing key components – described more broadly as repowering – could provide benefits that partially offset the cost of the CCS system, as currently expected for the Boundary Dam and FutureGen2 demonstration projects.

Cost of CCS

The capital cost of CSS retrofits is a barrier to their deployment. First-of-a-kind (FOAK) demonstration projects suggest that CCS retrofits of current technology would cost several thousand dollars per kilowatt of capacity. CCS cost reduction is a central goal of NETL's RD&D program. The goal for second generation technologies is to have a system capable of reducing capture costs from today's \$100-140/tonne CO₂ to \$40/tonne CO₂ captured that is "ready for demonstration in the 2020-2025 timeframe (with commercial deployment beginning 2025)."¹²⁷

Demonstrations and large pilot plants are progressing in various states for each of the three major CCS categories. The significant demonstrations that are operating or planned, are discussed below, including shortcomings and additional information required for commercial duty. Figure D.4.1 presents a timeline of the key demonstrations and experience anticipated to influence the commercial feasibility of CCS in the U.S. and North America.

Figure D.4.1. Timeline for CCS.

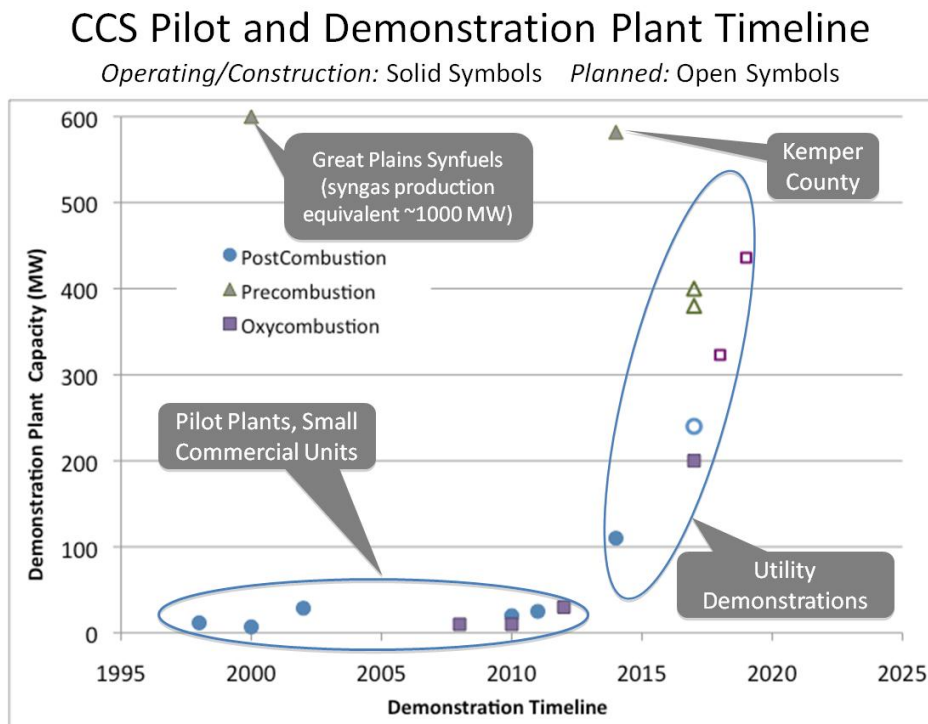

The time projected by NETL to develop affordable retrofit CCS technologies and the age of the existing fleet are in conflict. Assuming optimistic outcomes to RD&D, units being designed in 2025 will not begin operation before 2030, and multiple replications of 2nd Generation technology may be needed before costs achieve the stated goals. As shown in Figure C.8, only 43 GW of the 310 GW coal fleet will be less than 40 years of age in 2025. That capacity (units less than 40 years of age) shrinks to just 26 GW in 2030. Units repowered with CCS may have more “age tolerance” than simple retrofits, because in a repowering project, some of the major components at a power plant are replaced. Decisions on whether to retrofit capital intensive hardware, such as CCS systems, are based on multiple economic factors, some of which relate to the remaining useful life of potential retrofit candidates, and some of which are highly uncertain when projected 15 years into the future. These uncertainties include the capital cost of competing electricity generation technologies, new environmental requirements and the future price of natural gas. Nevertheless, mechanisms to accelerate the demonstration of much lower cost CCS systems should receive greater attention.

Process Descriptions

Numerous approaches are being pursued to remove or concentrate CO₂ from fossil fuel power generators. However, options with near-term payoff – meaning those past the laboratory stage and in duty at pilot-scale or small commercial units – are limited. These technologies can be organized into three major categories: (a) post-combustion, where CO₂ is removed from fossil-

National Coal Council – Reliable & Resilient: The Value of Our Existing Coal Fleet

fuel combustion products; (b) pre-combustion, where CO₂ is captured prior to combustion of the gasification-produced synthesis gas, and (c) oxycombustion, where combustion occurs in an oxygen rich atmosphere. Further details of the two processes considered prime candidates for retrofit – post-combustion and oxycombustion - are described in the NCC report addressing CCS¹²⁸, and also in Appendix B. Highlights are presented below.

Post-combustion Capture. Post-combustion capture is a CO₂ retrofit amenable capture alternative. CO₂ capture from combustion products can utilize a chemical reagent with a strong affinity for CO₂. Capture processes are based on chemical absorption, physical adsorption, gas permeation (membrane separation) or phase separation (e.g., cryogenic), with each approach offering advantages and disadvantages. Adsorption and absorption require CO₂ to be regenerated as a CO₂-rich stream. Processes using chemical absorption, including amine-based sorbents, appear closest to commercial feasibility, although others are feasible and being developed.

Dry regenerable sorbents may also prove attractive for retrofit CCS applications. These materials, which include dry sodium carbonate and amine-grafted zeolites, can physically absorb CO₂ and can regenerate a high purity CO₂ stream while consuming much less energy. Pilot-scale tests exploring the efficacy of various solid sorbents are being conducted, and will identify candidate sorbents and process conditions for large pilot and commercial testing.¹²⁹

Capture by gas permeation refers to membrane capture. This technology is interesting because CO₂ can be separated without the energy expensive regeneration step. However, much energy is required to pass the gas across the membrane due to the high pressure drop, membranes are susceptible to fouling and membranes will be very large for commercial applications. MTR currently has small-scale tests ongoing at locations across the U.S.

Phase separation is not as advanced as other methods of capture, but it is expected to reduce parasitic load due to the removal of energy expensive regeneration steps. Cryogenic CO₂ capture is one method currently in discussion, but it is far from commercial application. Trial tests have encountered heat exchanger fouling and plugging issues. However, at least one company, Sustainable Energy Solutions, believes it has the solution. Tests of this process will soon begin at the National Carbon Capture Center in Wilsonville, AL.

Oxycombustion. As the name implies, oxycombustion is based on firing coal with oxygen instead of air (which is 80% nitrogen). The result is a flue gas nearly exclusively comprised of CO₂ and water vapor. This CO₂-rich “flue gas” has a different emissivity and therefore different heat transfer properties than traditional power plants, and a relatively concentrated CO₂ stream would facilitate a CO₂ capture and storage system. The gas stream contains trace constituents of sulfur (SO₂ and SO₃), mercury and NO_x derived from the fuel that must be removed. Oxycombustion is applicable to both new generation and retrofit to existing units. The most notable example of oxycombustion retrofit to an existing unit is the FutureGen2 project.

Several variants of oxycombustion exist. One variant is characterized by the method of air separation, typically either cryogenic or membrane-based technologies. A second variant is defined by how combustion products (primarily CO₂) are recirculated within the boiler to control

National Coal Council – Reliable & Resilient: The Value of Our Existing Coal Fleet

heat transfer and operating temperature, assuring safe operating limits of available boiler materials. All of these oxycombustion variants appear feasible at this time.

The Status of CCS Technology

Post-combustion CCS projects. A summary of post-combustion pilot and demonstration projects relevant in early 2014 is presented in Appendix B (Tables Appendix B-1 and Appendix B-2). An abbreviated description follows.

The only project shown as complete in Table Appendix B-1 is the American Electric Power (AEP) Mountaineer project, a 20 MW pilot plant based on Alstom's chilled ammonia process. This pilot plant captured CO₂ from approximately 1.5% of the plant's total output and transported the CO₂ to onsite injection wells for deep saline aquifer storage. The system operated over a period of 20 months and was shut down, although monitoring of the injected CO₂ continues. AEP is monitoring the injected CO₂ plume at the sequestration sites, and Alstom is further testing the chilled ammonia process on a 40 MW-equivalent pilot plant fueled by natural gas, at a test center in Mongstad, Norway.

Four other coal-fired units shown in Table Appendix B-1 provide flue gas for CO₂ capture: for three the CO₂ is used for either commercial purposes or released. These plants are:

- AES/Warrior Run, with a 12 MW-equivalent slipstream from a 225 MW coal-fired plant with CO₂ supporting food processing at an adjacent site,
- AES/Shady Point, with a 7 MW-equivalent slipstream from a 175 MW coal-fired power plant, also for food processing, and
- Nirma/Searles Valley Minerals, with CO₂ from this 28 MW coal-fired plant used for on-site mineral processing.

Southern Company's Plant Barry is the only remaining pilot scale demonstration project (25 MW) at an operating power plant which includes capture, transport and sequestering of CO₂. Operation of Plant Barry's system started in June of 2011 (capture only), with sequestration in a saline reservoir initiated in August of 2012. Capture operations will continue through 2014, and monitoring of the sequestration site will continue through 2016.

Two North American post-combustion CCS projects are either in final construction stages, or are engaged in planning and financing efforts. Unit 3 of SaskPower's Boundary Dam station will utilize an amine-based process to remove CO₂ (and SO₂). This 110 MW unit will produce 1 million tons of CO₂ per year, most of which will be used for EOR at the Weyburn fields. The unit is expected to be operating in 2014. In addition, NRG Energy's W.A. Parish project, is conducting an engineering study for a 240 MW-equivalent demonstration project using Fluor's Econamine amine-based CO₂ control process. The Parish demonstration has not yet secured financing¹³⁰. The earliest the unit will operate is 2015 – pending financing.

Additional post-combustion CCS projects are underway outside North America. Differences in fuel composition, plant design and plant operating duty, may limit their applicability to North American units.

National Coal Council – Reliable & Resilient: The Value of Our Existing Coal Fleet

Four pilot plants presently operate outside North America. These are at:

- Wilhelmshaven, where E.ON operates a 3.5 MW equivalent pilot plant at this North Sea site,
- Brinidisi where ENEL operates a 48 MW pilot plant, capturing CO₂ since 2011 for use at the nearby Stogit oil field for EOR,
- Ferrybridge, where Scottish and Southern Energy operate a 5 MW pilot plant which commenced operation in 2012 and will operate through 2013, and
- EDF LeHarve, where Alstom and Dow Chemical are experimenting with state-of-the-art amines.

The captured CO₂ is not transported or sequestered. Further details are provided in Appendix B.

The status of post-combustion CCS is that:

- No power plant employing commercial scale post-combustion CCS exists;
- One such commercial scale project, Boundary Dam, is scheduled to begin operations later in 2014, but the actual cost of this system would probably be prohibitively expensive for general application; and
- One additional demonstration project (W.A. Parish) is on the horizon and, if built and operated, could provide valuable information on CCS after 2016.

Additional pilot scale activity is underway and could help NETL achieve its research goal of having a more affordable 2nd Generation CCS technology available for demonstration by 2020-2025, with commercial deployment a few years later.

Oxycombustion CCS Projects. Table Appendix B-3 summarizes projects involving oxycombustion and CCS systems. Two pilot plant test programs have been completed and a third is in progress to provide exploratory data at small scale, and the basis for generalizing design to larger capacities. The first is a Babcock & Wilcox 10 MW-equivalent pilot plant, which provided process data as a precursor to the FutureGen2.0 project. The test totaled less than 300 hours but results provide a first step for a demonstration plant. Testing included oxygen separation and production of a nearly pure CO₂ effluent.

The second is the Total (Lauq, France) 10 MW pilot plant – although firing natural gas – and operated at Total's Lacq Refinery from 2010 through 2013. Although not fueled by coal this unit is of interest as there is little relevant process information on oxycombustion systems. The 75,000 tons of CO₂ collected were injected into a depleted natural gas field.

A third pilot plant – jointly funded by DOE and Jupiter Oxygen – addresses a promising variant of oxycombustion. This 5 MW-equivalent pilot facility evaluated burners for firing coal with oxygen, operating periodically in test modes from 2006 through 2012.

Two oxycombustion pilot scale CCS projects are now operational and conducting all three steps of oxycombustion, CO₂ separation and reuse or sequestration. The 10 MW Vattenfall AB project in Schwarze Pumpe, Germany fires coal and is halfway through a decade long test. This test started in 2008 and includes oxycombustion, CO₂ capture and injecting 75,000 tons of CO₂ annually into a depleted gas field. A decade of operation reflects the time required to acquire data from

National Coal Council – Reliable & Resilient: The Value of Our Existing Coal Fleet

different fuels and operating conditions. CS Energy has operated a 30 MW equivalent pilot plant – at present the largest in the world – at the Callide Station since 2012. Two years of tests are planned and include sequestering CO₂ in a saline reservoir. Pending successful results a 150-200 MW unit will be built and tested for 3-4 years.

The only North American coal-based large-scale oxycombustion project is the DOE-funded FutureGen2.0 at Ameren’s Meredosia station. This demonstration project entails converting a 167 MWe (gross) conventional unit to oxycombustion. The plant is designed to fire fuel using oxycombustion; clean and compress 90% (1.3 M tons) of the CO₂ produced; and transport it 175 miles by pipeline for sequestration in a saline reservoir in Mattoon, Illinois. The project plans to commence operation by 2017.

Two additional commercial-scale oxycombustion projects - the White Rose and OXYCFB 300 - are being considered in the UK and Spain. White Rose is scheduled to make a final investment decision in 2015, if favorable to commence construction in 2016, and become operational in 2016.¹³¹ It is unclear whether the OXYCFB 300 project will move forward.¹³²

In summary, oxycombustion CCS systems somewhat lag the development of post-combustion systems. Current experience is limited to pilot scale projects ranging from 10 MW to 30 MW in capacity. However, FutureGen2, when built, will provide commercial scale experience with this technology, and startup is scheduled for 2017. Additionally, FutureGen2 will be one of the few commercial scale projects integrating CO₂ capture with storage in a saline reservoir.

The Status of CO₂ Storage Technology

CO₂ once captured at a power plant must be transported and permanently stored, or reused in a manner that does not allow eventual release. CO₂ transport by pipeline is mature, but the pipeline infrastructure within most states for transport to a storage site must be expanded to broadly deploy CCS. Significant investment will be required. As of 2010, industry had invested over \$2.2 B for 2,200 miles of CO₂ pipelines in the Permian Basin alone. Technical challenges to safe and reliable CO₂ transport exist but can likely be overcome – such as specifying the proper materials-of-construction and minimizing corrosive species in the gas stream. Non-technical issues are likely more significant. These include right-of-way access, multi-state jurisdictions and issues related to worksites and population centers.

Saline Storage. The DOE and the United States Geological Survey (USGS) have estimated the potential CO₂ storage capacity available in deep saline reservoirs, with DOE reporting capacity by state¹³³ and the USGS by storage basins.¹³⁴ The USGS concluded the Gulf Coast area contains almost 60% of the national CO₂ storage capacity. The DOE identifies many locations in the U.S. that have access to potential significant sequestration capacity, but numerous locations remain under-served.

The CO₂ storage capability of any saline site is unknown until the site is assessed for specific physical and geotechnical features. Such assessments are sophisticated and typically cost tens of millions of dollars. Both the International Energy Agency (IEA) and the Global CCS Institute state between 5 and 10 years are required to qualify a new saline formation for CO₂ storage, and in some cases even longer.^{135, 136} As noted in the 2012 (First) Edition of the North American Carbon Storage Atlas, “It is important that a regionally extensive confining zone (often referred to as

National Coal Council – Reliable & Resilient: The Value of Our Existing Coal Fleet

caprock) overlies the porous rock layer and that no major faults exist.”¹³⁷ The same reference cites the importance of documenting the CO₂ storage capability, “injectivity” and the ability of the porous rock to permanently trap CO₂.

Saline storage of CO₂ also poses non-technical challenges, including establishing pore space ownership and other property rights issues, and long-term liability. The legal framework based on oil and gas rights may not apply to injecting and storing large CO₂ quantities as required for power plants. Further complicating matters is the extended time for monitoring and site responsibility, well beyond that for oil/gas experience.

The long-term liability of CO₂ storage, due to potential migration of the plume or leaks or diversion of CO₂ to pore spaces not in the confining area, poses a possible financial risk. The time scale of liability could exceed the life of the corporate or business entity. Moreover, the time scale of present RD&D projects to demonstrate securing CO₂ – perhaps 5 years – does not match the time scale of liability. This latter risk exposure will exceed 100 years, assuming 50 years of injection at a site and an additional 50 years of post-injection monitoring. All risks may not be identified.

Storage of CO₂ in EOR Projects. Almost all current integrated CCS projects underway or planned in the U.S. employ EOR for CO₂ storage (FutureGen2 is a notable exception). CO₂ has been used to increase production of oil or gas in partially depleted reservoirs for decades, but it has not been used in conjunction with coal-fired power generation.

DOE estimates CO₂ can be productively used for EOR; but sites are not uniformly distributed in the U.S. Certain Midwestern and Gulf Coast states have notable EOR potential, but the Pacific Northwest and much of the eastern seaboard area do not.¹³⁸ This regional availability of EOR is unlikely to be resolved by additional RD&D; it is a limiting physical reality. Because EOR sites have already been extensively characterized for primary and secondary oil production, their subsurface physical characteristics are generally better understood than those of potential saline sites. As a result, the time period for full characterization for CO₂ injection is expected to be less than the 5-10 years for saline reservoirs.¹³⁹

Not all states clearly specify surface versus subsurface property rights – which will lead to conflicts of interest and potential litigation. In addition to property rights issues, environmental responsibilities associated with CO₂ stored in EOR reservoirs are still evolving. EPA regulations reserve the right to change storage requirements after a project is initiated if the permitting authority or EPA anticipates an increased risk to drinking water resources. The recently proposed CO₂ NSPS rules specified more stringent monitoring and reporting requirements for power plant CO₂ used for EOR versus “natural” CO₂ used for EOR. According to a major EOR operator, “the proposed NSPS rule will foreclose – not encourage – the use of CO₂ captured by emissions sources in EOR operations.”¹⁴⁰ It is unclear whether these rules, when finalized, will allow the flexibility needed by EOR operators in practical EOR projects.

National Coal Council – Reliable & Resilient: The Value of Our Existing Coal Fleet

iii. Findings

- Commercial scale CCS has yet to be demonstrated due to a number of significant technical, financial, legal and regulatory challenges. Because of the broad scope and magnitude of CCS development issues, the timeline for any commercial-scale project could be expected to require at least a decade from the project concept to assessment of operational data. As a result, there are practical limits to how soon RD&D results can be applied in the marketplace.
- Nevertheless, if CCS is to become a viable technology, then a focused and aggressive effort to overcome the technical, financial, regulatory and legal barriers is needed on behalf of industry, regulators and technology developers. This would include a broad set of projects to demonstrate the feasibility of the technology, and establish a basis for an industry using the range of coal types mined in the U.S., various power plant types and both EOR and saline CO₂ storage options. Two previous reports by the National Coal Council,¹⁴¹ as well as the report by the Interagency Task Force on Carbon Capture and Storage,¹⁴² all recommended 5-10 GW of commercial scale CCS demonstrations.
- No power plant with commercial scale CCS presently operates. One post-combustion project fueled by lignite is scheduled to begin operation in 2014 and will provide process design and integration experience.
- Retrofitting CCS creates challenges that go far beyond those that apply to greenfield CCS applications: including integration with unit operations, less design and operational flexibility, fixed locations, limits on available space, significant concerns regarding the availability of geologic sequestration options, immature state regulatory programs and, perhaps most importantly, a limited time window.
- Expediently conducting this research and demonstration is critical to serve the existing fleet. The capacity-weighted average age of existing U.S. coal-fired power plants is 39 years. Significant progress must be achieved in the next decade to support the existing fleet, which in 2025 will average 50 years of service.
- In general, the DOE R&D program has sufficient scope to address the technical challenges posed by current gaps in understanding related to carbon capture and compression technology. However, the program has no financial resources to move viable R&D concepts through commercial scale demonstration, which is essential to making those concepts commercially viable. Additionally, there is no effort underway to address the long-term legal liability associated with CO₂ storage in the decades following completion of a CO₂ injection project.
- Considerable challenges still exist with respect to carbon storage and EOR, both technical and non-technical.
- Approximately 12 large scale carbon capture and storage demonstration projects are needed to adequately demonstrate CCS is technically feasible and commercially-viable for coal-based generating units; half for EOR and half for saline formations.
- System optimization for partial CO₂ capture may yield benefits in reduced parasitic power consumption and easier integration with existing power plants.

National Coal Council – Reliable & Resilient: The Value of Our Existing Coal Fleet

iv. Recommendations

- DOE should lead collaborative work with industry to demonstrate at commercial scale lower cost post-combustion CCS systems with less parasitic power consumption for bituminous and subbituminous coals.
- DOE should lead a collaborative program to demonstrate retrofit of existing units with oxycombustion technology as an approach that would require lower resources and less time to implement than greenfield oxycombustion applications.
- At the research level, DOE efforts should evaluate and develop small footprint concepts for post-combustion capture, systems with reduced parasitic energy needs and dry sorbents producing carbonates. Process integration resulting in greater recovery of low quality heat energy should also be a priority. Given the potential role of oxycombustion, lower cost oxygen separation technologies should continue to receive attention.
- DOE R&D should explore partial CO₂ capture by processing not the entire gas stream but a fraction for high CO₂ removal, as a means to reduce parasitic power consumption and ease integration at existing sites.
- DOE should lead collaborative efforts with industry to improve CO₂ plume monitoring techniques for both saline and EOR formations. Similarly, DOE should lead R&D efforts to develop improved systems for evaluating potential CO₂ storage formations at lower cost and with greater certainty than current systems.
- DOE should work with regulatory agencies to ensure that monitoring requirements placed on EOR systems used for compliance with CO₂ emission limits at power plants do not extend beyond provisions that ensure that CO₂ is not released from the EOR field to the atmosphere.
- DOE should continue work on “best practices” reports related to CCS legal framework issues. The Department should also collaborate with regulatory agencies to target development of plume modeling and monitoring technologies that could mitigate the financial risk exposure from RCRA, CERCLA and long term liability under UIC.

APPENDIX A

**Turbine Upgrade or Efficiency Improvement Projects Cited in NSR
Enforcement Initiative**

APPENDIX A

Turbine Upgrade or Efficiency Improvement Projects Cited in NSR Enforcement Initiative

This list is limited to turbine upgrades or replacements – the list would be much longer if improved materials of construction and improved designs of heat transfer surfaces were included.

1. Turbine Upgrade or Efficiency Improvement Projects Cited in NSR Enforcement Initiative

- *United States v. Duke Energy Corp.*, No. 00-cv-01262 (M.D.N.C. Dec. 22, 2000) (GE Dense Pack turbine upgrades at Belews Creek Units 1 and 2 and Marshall Unit 3);
- *New York v. Niagara Mohawk Power*, No. 02-CV-24, Compl. (W.D.N.Y. Jan. 10, 2002), ¶ 202 (“upgraded the turbine” on Huntley Unit 63 in 1987), ¶ 323 (“replaced the turbine” on Huntley Unit 67 in 1991);
- *United States v. East Kentucky Coop.*, No. 04-34-KSF, Compl. (E.D. Ky. Jan. 28, 2004), ¶ 60 (“replacement or renovation ... of major components of the ... turbine at the unit” on Dale 4 in 1995-1995), ¶ 76 (“replacements or renovations of major components of the ... turbine” on Dale 3 in 1996);
- *Sierra Club v. Portland General Electric*, No. 08-cv-01136, Am. Compl. (D. Or. Nov. 29, 2010), ¶ 134 (“a plant turbine upgrade” at Boardman in 2003);
- *United States v. Ameren Missouri*, No. 4:11-cv-77, Am. Compl. (E.D. Miss. June 28, 2011), ¶ 67 (“associated turbine replacements” at Rush Island Unit 1 in 2001-2002), ¶ 73 (“associated turbine replacements” at Rush Island Unit 2 in 2003-2004);
- *Conservation Law Foundation, Inc. v. Public Service of New Hampshire*, No. 11-cv-00353, Compl. (D.N.H. July 21, 2011), ¶ 49 (“removed a high pressure/intermediate pressure turbine, and replaced it with a new HP/IP turbine” at Merrimack Unit 2 in 2008);
- *Dine Citizens Against Ruining Our Environment v. Arizona Public Service Company*, No. 1:11-cv-889, Am. Compl. (D.N.M. Jan. 6, 2012), ¶ 48 (“replacement of the high pressure turbines” at Four Corners Units 4 and 5 in 2007), *id.* (“Plaintiffs are informed and believe ... that these high-pressure turbine upgrades increased the design-level heat input rate of each of these units, thereby increasing each unit’s generating capacity and its potential to emit air pollution.”);
- *United States v. Dairyland Power Coop.*, No. 12-cv-462, Compl. (W.D. Wisc. June 28, 2012), ¶ 38 (“upgrading of the turbine at the J.P Madgett Unit in 2004”);
- *Sierra Club v. PPL Montana LLC*, No. 1:13-cv-32, Am. Compl. (D. Mont. Sept. 27, 2013), ¶ 55 (“Replacement of the Low Pressure Turbine” on Unit 3 in 2011), ¶ 57 (“High Pressure/Intermediate Pressure Turbine Replacement” at Unit 2 in 2008), ¶ 58 (“High Pressure Turbine Replacement” at Unit 3 in 2007), ¶ 59 (“High Pressure Turbine Replacement” at Unit 4 in 2006), ¶ 60 (“Replacement of the High Pressure and Intermediate Pressure Turbines” at Unit 1 in 2006).

National Coal Council – Reliable & Resilient: The Value of Our Existing Coal Fleet

2. Standard Turbine Overhauls or other Turbine Projects Cited in NSR Enforcement Initiative

- *United States v. Cinergy*, No. IP99-1693, Third Am. Compl., (S.D. Ind. June 29, 2006) at ¶ 172 (replacement of “turbine blades” on Beckjord Unit 6 in 1994);
- *United States v. Duke Energy Corp.*, No. 00-cv-01262, Compl. (M.D.N.C. Dec. 22, 2000), ¶ 32 (“turbine overhaul” at Allen Unit 5 in 2000), ¶ 60 (“turbine overhaul” at Allen Unit 4 in 1998), ¶ 195 (“turbine rehabilitation” at Cliffside Unit 4 in 1990);
- *Sierra Club v. Dayton Power & Light, Inc.*, No. C2-04-905, Compl. (S.D. Ohio Sept. 21, 2004), ¶ 43 (“overhaul of the turbine” on Stuart Unit 1 in 1980);
- *United States v. American Electric Power*, No. C2-05-360, Compl. (S.D. Ohio Apr. 8, 2005), ¶ 97 (“replacement of the low pressure turbine rotor” on Conesville Unit 5 in 1997), *id.* (“replacement of the low pressure turbine rotor” on Conesville Unit 6 in 1997);
- *Sierra Club v. PPL Montana LLC*, No. 1:13-cv-32, Am. Compl. (D. Mont. Sept. 27, 2013), ¶¶ 53 (“Low Pressure Turbine Overhaul” at Unit 1 in 2012), *id.* (“Turbine/Generator Base Overhaul” at Unit 1 in 2012), ¶ 54 (“Turbine Generator Base Overhaul” on Unit 2 in 2011), ¶ 55 (“Turbine Generator Base Overhaul” on Unit 3 in 2011), ¶ 55 (“Intermediate Pressure Turbine Overhaul” on Unit 3 in 2011), *id.* (“Turbine/Generator Base Overhaul” on Unit 3 in 2011), ¶ 56 (“LP1 & LP2 Turbine Rebuild” at Unit 4 in 2009), *id.* (“Low Pressure Turbine” at Unit 4 in 2009), *id.* (“Turbine/Generator Base Overhaul” at Unit 2 in 2008), *id.* (“Low Pressure Turbine Overhaul” at Unit 2 in 2008), ¶ 59 (“Intermediate Pressure Turbine Overhaul” at Unit 4 in 2006).

APPENDIX B
Present Technical Status of CCS

APPENDIX B

Present Technical Status of CCS

1. Introduction

Appendix B presents a summary of the technical status of CCS in 2014 in more detail than addressed in the text of this report. The status of the two options featured in this report that are considered the best candidates for retrofit – post-combustion control and oxycombustion – are addressed in Appendix B.

2. Post-combustion Control

The key post-combustion control processes that are relevant to the technical status of CCS are summarized in Table Appendix B-1. These operating processes, demonstrations, or pilot plants (greater than 3 MW-equivalent capacity) are discussed according to the status: Completed; Operating; or Planning. A sampling of projects (not a complete or comprehensive list) that are proposed or planned outside North America is also presented.

Post-combustion Control Projects: Completed. The sole project completed is the American Electric Power (AEP) 20 MW pilot plant based on Alstom’s chilled ammonia process, which operated for a period of 20 months.

Post-combustion Control Projects: Operating. Five coal-fired units are the source for captured CO₂ that is used for either commercial purposes or for a pilot plant test.

Three units support producing of food or chemicals and do not transport or sequester CO₂. These plants are: (a) AES/Warrior Run, with a 12 MW-equivalent slipstream from a 225 MW coal-fired plant supporting food processing at an adjacent site, (b) AES/Shady Point, with a 7 MW-equivalent slipstream from a 175 MW coal-fired power plant, also for food processing, and (c) Nirma/Searles Valley Minerals, with flue gas from this 28 MW coal-fired plant provides CO₂ for on-site mineral processing. A fourth 5 MW-equivalent pilot plant operates at EDF’s Le Havre station, testing advanced amine compounds developed by Alstom and Dow Chemical.

Only the fifth pilot plant, Southern Company’s 25 MW-equivalent Plant Barry demonstration, includes a scope that includes transporting and sequestering CO₂. This demonstration of MHI’s amine-based technology removes approximately 500 tons of CO₂ per day from flue gas at Alabama Power’s Barry Unit 3. This project, in addition to demonstrating CO₂ capture, employs compression, pipeline delivery, and sequestration of CO₂ in saline aquifers. Operation started in June of 2011 (capture only), with sequestration initiating in August of 2012. Operations will continue through 2014, including monitoring of the sequestration site through 2016.

Post-combustion Control Projects: Planning. Two North American projects are relevant: one in final construction, and one in planning and financing.

SaskPower. Unit 3 of SaskPower’s Boundary Dam station will utilize an amine-based process to remove CO₂ (and SO₂). This 110 MW unit will produce 1 M tons of CO₂ per year, most of which will be deployed for EOR at the Weyburn fields. The unit is expected to be operating in 2014.

National Coal Council – Reliable & Resilient: The Value of Our Existing Coal Fleet

W.A. Parish. An engineering study is underway for a 240 MW-equivalent demonstration plant using Fluor's Econamine amine-based CO₂ control process. The Parish demonstration is not finalized as financing is not secured - a late 2013 decision anticipated.^{xv} The earliest the unit will operate is 2015 – pending financing.

Post-combustion Control Projects: Outside North America. Several post-combustion CO₂ control projects operate outside of North America, with additional demonstration plants planned. Differences in fuel composition, plant design, and plant operating duty, may limited applicability to North American units.

Three pilot plants – ranging in equivalent generating capacity from 3.5 to 48 MW – presently operate. These are at (a) Wilhelmshaven, where E.ON operates a 3.5 MW equivalent pilot plant at this North Sea site, (b) Brinidisi where ENEL operates a 48 MW pilot plant, capturing CO₂ since 2011 for use at the nearby Stogit oil field for EOR, and (c) Ferrybridge, where Scottish and Southern Energy operate a 5 MW pilot plant which commenced operation in 2012 and will operate through 2013. The captured CO₂ is not transported or sequestered.

Additional post-combustion control demonstrations at commercial scale are planned, but status is uncertain as financing is not complete. Examples of such projects, for which capture of CO₂ will not be attained until 2015 at the earliest, are a scale-up of the 5 MW pilot plant at Ferrybridge (UK) and ROAD (Netherlands).

Analysis Summary: The sole relevant experience in North America with post-combustion CO₂ control is with Plant Barry's 25 MW-equivalent pilot plant. The SaskPower 110 MW Boundary Dam unit may soon be operating and provide similar information. The commercial units (Warrior Run, Shady Point, Searles Valley Minerals) do not provide authentic utility experience or a complete scope. A summary of experience derived, additional experience required, and possible future actions for selected pilot plants is presented in Table Appendix B-2.

^{xv} DOE Issues Final EIS for W.A. Parish, GHG Monitor, March 13, 2013, available at <http://ghgnews.com/index.cfm/doe-issues-final-eis-for-wa-parish/>

National Coal Council – Reliable & Resilient: The Value of Our Existing Coal Fleet

Table Appendix B-1. Summary of Post-combustion CO₂ Pilot Plant and Demonstration Projects: North America and Europe.

Project	Host (Co-Sponsors)	Capacity (MW) CO ₂ Removed/Yr	CO ₂ Capture Technology	CO ₂ Fate	Construction Initiated/ Operational	Cost, \$M
Mountaineer	AEP (Alstom, others) ¹	20 MW pilot plant. 51,300 metric tons CO ₂ captured and 37,400 metric tons CO ₂ stored	Post-combustion: Chilled ammonia	Saline: 1.5-mile depth in Mt. Simon Sandstone	Operations: Sep '09 thru May '11. Post-injection monitoring ongoing.	100
Warrior Run	AES	12 MW. 110,000 tons/yr	Post-combustion amine	On-site food production	Operating since 2000	N/A
Shady Point	AES	7 MW. 66,000 tons/yr	Post-combustion amine	On-site food production	Operating since 2000	N/A
Searles Valley Minerals	Nirma	28 MW. 270,000 tons/yr	Post-combustion amine	Chemicals production	Operating since 1995	N/A
Plant Barry	Southern Company, MHI, EPRI	25 MW pilot plant; 550 tons/day CO ₂	Post-combustion: MHI KM-CDR amine process	Saline: 11-mile pipeline to Citronelle dome (0.44 tons/4 yrs)	Operations: 2Q/2011 to 4Q/2014	TBD
W.A. Parish	NRG Energy (DOE)	240 MW 1.65 M tons CO ₂ /year	Post-combustion: Fluor Econamine, experimental reagents	EOR: 80 miles to Hilcorp's West Ranch	Operations: planned 2015	339
Boundary Dam (Unit 3)	SaskPower Alliance	110 MW 1 M tons CO ₂ /year	Post-combustion: Cansolv	EOR at Weyburn, excess CO ₂ to saline reservoir	Construct: 2012 Operation: 2014	1,335 (Canadian)
Brindisi	ENEL, Eni	48 MW pilot plant 8,000 tons/y	Post-combustion – amine, others	EOR: Stogit field north Italy	Anticipated 2012 operation	400 (€)
Ferrybridge	Scottish Southern Energy	5 MW pilot plant 350,000 tons/yr	Post-combustion amines	Release after capture	Nov 2012 through 2013	21 (£)
Le Havre	EDF	5 MW pilot plant	Post-combustion amines	Release after capture	July 2013 through March 2014	N/A
Wilhelmshaven	E. On	3.5 MW pilot plant	Fluor Econamine	Release	2012-present	N/A

Note: Capacity reported as gross electric MW, unless noted otherwise.

¹ Chilled ammonia work continues at the European CO₂ capture pilot plant, the Test Center Mongstad, Norway, on natural and refinery gas products.

National Coal Council – Reliable & Resilient: The Value of Our Existing Coal Fleet

Table Appendix B-2. Post-combustion CO2 Controls: Experience and Lessons Learned.

Project	Capacity (MW) Technology	Status	Experience Derived	Additional Experience Required	Possible Future Actions
AEP/Mountaineer	20 MW pilot plant: chilled ammonia	Complete	Confirm process chemistry, control system strategies	Scale-up of heat exchangers, absorbers, process controls	200 MW demo for E. bit, subbit coal
Plant Barry	25 MW pilot plant: advanced amine reagent	In operation	Experience with advanced (MHI KM-CDR) reagent; integrate heat balance	Scale up of heat exchangers, absorbers and regeneration towers, process control	200 MW demo for E. bit, subbit coal
W.A. Parish	240 MW 1.65 M tons CO ₂ /year	Design & planning	This will represent the largest amine-based CO ₂ capture test in the world	Process integration at commercial scale, operating in support of EOR	Long-term operation exercising various load-following modes.
Boundary Dam (Unit 3)	110 MW 1 M tons CO ₂ /year	Startup in 2014	Small commercial size (100 MW) but a valued step to address process integration	Same as above	Same as above
Brindisi	48 MW pilot plant 8,000 tons/yr	In operation (confirm)	Confirm process chemistry, control system strategies	Generalize results to 250-500 MW	Exercise various load-following modes
Ferrybridge	5 MW pilot plant 350,000 tons/yr	Complete	Confirm process chemistry, control system strategies	Generalize results to 250-500 MW	Apply design basis to larger scale
Le Havre	5 MW pilot plant	In operation	Develop advanced amines	Generalize results to 250-500 MW	Apply design basis to larger scale
Wilhelmshaven	3.5 MW pilot plant	In operation	Confirm process chemistry, control system strategies	Generalize results to 250-500 MW	Apply design basis to larger scale

National Coal Council – Reliable & Resilient: The Value of Our Existing Coal Fleet

3. Oxycombustion

Oxycombustion: Completed. Two pilot plant test programs have been completed and provide exploratory data at small scale and limited operation.

Babcock & Wilcox. A 10 MW-equivalent pilot plant provided process data as a precursor to the FutureGen2.0 project.¹⁶ The test totaled less than 300 hours but results provide a first step for a demonstration plant. Testing included oxygen separation and production of an exclusive CO₂ effluent.

Total (Lauq, France). A 10 MW-equivalent pilot plant firing heavy fuel oil operated at Total's Lacq Refinery from 2010 through 2013. This unit is cited even though experience is with natural gas and not coal as there is little process information on any fuel. The 75,000 tons of CO₂ collected are injected into a depleted natural gas field.

Jupiter Oxygen (Hammond, IN). A 5 MW-equivalent burner test facility, funded by DOE and Juniper Oxygen, addressed combustion of coal in oxygen, heat transfer, and materials performance. Tests were conducted periodically from 2006 through 2012. A smaller 20 kW-equivalent test apparatus simulates the train of process equipment for combustion product clean-up. CO₂ captured is released as research activities focus on developing and refining engineering principles for oxycombustion.

Oxycombustion Control Projects: Operating. Two demonstration units at small scale simulate a complete scope of CO₂ separation and reuse or sequestration.

Vattenfall AB. This 10 MW pilot plant in Janschwalde, Germany fires coal and is halfway through a decade long test. This test started in 2008 represents a complete scope of activity, injecting 75,000 tons of CO₂ annually into a depleted gas field. The planned decade of operation demonstrates the time that is required to methodically acquire data from different fuels and operating conditions.

Callide A Station. CS Energy has operated a 30 MW equivalent pilot plant – at present the largest in the world – at the Callide Station since 2012. Two years of tests are planned and include sequestering CO₂ effluent in a saline reservoir. Pending successful results a 150-200 MW unit will be built and tested for 3-4 years.

Oxycombustion Control Projects: Planning. The sole North American project is the U.S. DOE-funded FutureGen2.0. This demonstration entails converting a 167 MWe (gross) conventional unit at Ameren's Meredosia station to oxycombustion. A complete scope of activities is planned: cleaning and compressing 90% (1.3 M tons per year) of the CO₂ captured and transported 175 miles by pipeline for sequestration in a saline reservoir in Mattoon, Illinois. The project is planned to commence operation by 2017.

Oxycombustion Projects: Outside North America. Two demonstration projects are planned with 2018/2019 start dates but permit and finance fate are uncertain. The White Rose project was

¹⁶ *Technical Considerations for Oxycombustion Flue Gas Conditioning*, Babcock & Wilcox Technical Paper BR-1842, EPRI Power Plant "Mega" Symposium, Baltimore, MD, August 2010. This work is widely reported on the thermal-throughput basis, or 30 MW.

National Coal Council – Reliable & Resilient: The Value of Our Existing Coal Fleet

selected by the UK government as one of two key projects to receive a considerable subsidy. The OXYCFB 300 project – a 323 MW demonstration of a circulating fluid bed boiler fired as oxycombustion mode – is also being evaluated in a design study.

Analysis Summary: The only operating oxycombustion process experience is with four pilot plants. FutureGen 2.0 is planned for 2016 operation; two units in the U.K. are proposed but highly uncertain.

National Coal Council – Reliable & Resilient: The Value of Our Existing Coal Fleet

Table Appendix B-3. Status of Oxycombustion Demonstration Tests.

Utility/Operator	Electrical/Heat Throughput	CO₂ Fate	Construction or Test/Schedule	Cost, \$M (Total/Subsidy)
Jupiter Oxygen (Hammond, IN)	5 MW(e)	Capture and release	Periodic 5 MW-equivalent tests (2006–2012)	\$8.1 M (\$6.5 M from DOE, \$1.5 M from Jupiter Oxygen)
Lacq, Total, France	30 MW _i /10 MW(e) Natural gas	75,000 CO ₂ tons/yr injected in depleted gas field	Demonstration test starting 2010; completed 2013	Two year test 2010-2013. Government support for the 60 M € project is unknown.
Vattenfall AB Janschwalde, Germany	30 MW ^(thermal) (equivalent to 10 MW)	75,000 tons/yr, transported 400 m to gas field	Demonstration test starting 2008; continues through 2018	Continued commercial demonstration through 2018.
Callide A Station, CS Energy, Australia	30 MW(e)	0.27 tons/yr, sequestered on-site saline reservoir	Demonstration test starting 2012; continue through 2014	\$241 M (AUS). Startup operations commenced in early 2012.
FutureGen 2.0 Alliance	167 gross MW(e)	1.1 M tons/yr, transport via 29 mile pipeline to saline reservoir	2013 start of construction. Planned completion by 2017	1,650/1,000 Preliminary engineering complete. Completing financing and permitting.
White Rose	436 MW(e)	2 M tons/yr; offshore sequestration: saline reservoir	Final investment decision in 2015, possible initiation of construction in 2016. Start up 2020.	Selected by UK government in CCS Competition to receive funding. Preliminary engineering in progress.
Endesa/OXYCB 300 Compostilla	323 MW(e)	1.2 M tons/yr; sequestration: deep saline reservoir	Process design presently being defined. Possible initiation of construction in 2016. Start up 2018.	Preliminary engineering in progress.

APPENDIX C
2012 Generation, Million MWH by State

National Coal Council – Reliable & Resilient: The Value of Our Existing Coal Fleet

APPENDIX C

2012 Generation, Million MWH by State

State	2012 Generation, Million MWH						Total	Price c/kWh
	Coal	Natural Gas	Hydro	Nuclear	Wind	Other		
	(Data Source: USDOE/EIA)							
AK	0.64	3.86	1.43	-	0.01	1.04	6.98	16.33
AL	45.69	55.42	7.16	40.84	-	3.56	152.66	9.18
AR	28.43	17.50	2.17	15.49	-	1.79	65.38	7.62
AZ	40.21	30.32	6.73	31.93	0.26	1.25	110.69	9.81
CA	1.59	121.09	25.96	18.51	9.94	24.25	201.34	13.53
CO	34.64	10.83	2.00	-	6.04	0.07	53.59	9.39
CT	0.10	16.51	0.47	17.08	-	1.57	35.73	15.54
DC	-	0.08	-	-	-	0.01	0.09	11.85
DE	1.46	6.94	-	-	0.00	0.40	8.81	11.06
FL	44.37	149.25	0.15	17.87	-	9.11	220.75	10.44
GA	40.70	42.78	2.33	33.94	-	2.95	122.70	9.37
HI	1.53	-	0.09	-	0.37	8.09	10.08	34.04
IA	35.56	1.97	0.82	4.35	13.94	0.27	56.92	7.71
ID	0.08	1.94	11.75	-	1.82	0.59	16.18	6.92
IL	80.84	11.36	0.10	96.40	7.71	1.33	197.74	8.40
IN	92.58	14.61	0.46	-	3.16	3.87	114.68	8.29
KS	27.98	3.29	0.01	8.28	5.12	0.10	44.78	9.33
KY	82.57	2.97	2.38	-	-	1.91	89.82	7.26
LA	21.43	59.20	0.68	15.66	-	6.80	103.77	6.90
MA	2.10	24.42	0.97	5.86	0.09	1.96	35.40	13.79
MD	16.13	4.96	1.66	13.58	0.31	1.16	37.82	11.28
ME	0.05	6.18	3.53	-	0.88	4.41	15.05	11.81
MI	53.35	22.28	1.31	28.02	1.11	2.67	108.73	10.98
MN	23.06	7.18	0.74	11.94	7.53	2.11	52.56	8.86
MO	72.87	6.24	0.72	10.72	1.25	0.19	91.98	8.53
MS	7.21	38.25	-	7.30	-	1.43	54.19	8.60
MT	14.21	0.17	11.30	-	1.24	0.81	27.73	8.25
NC	51.01	19.42	3.52	39.39	-	2.70	116.02	9.15
ND	28.23	0.03	2.48	-	5.32	0.13	36.18	7.83
NE	25.11	0.86	1.51	5.80	1.27	0.09	34.64	8.37
NH	1.27	7.03	1.29	8.19	0.26	1.23	19.27	14.19
NJ	1.90	27.22	0.03	33.11	0.01	1.82	64.09	13.68
NM	25.00	8.75	0.20	-	2.23	0.40	36.57	8.83
NV	4.08	25.66	2.44	-	0.13	3.26	35.57	8.95
NY	4.55	59.99	25.06	40.77	3.03	3.56	136.97	15.15
OH	86.02	22.63	0.38	17.09	0.99	2.20	129.31	9.12
OK	29.28	39.41	1.14	-	8.23	0.20	78.27	7.54
OR	2.63	11.63	39.26	-	6.07	0.79	60.37	8.21
PA	88.03	53.11	2.31	75.17	2.21	3.88	224.71	9.91
RI	-	8.22	0.01	-	0.00	0.14	8.37	12.74
SC	28.49	14.13	1.40	51.15	-	1.35	96.51	9.10
SD	2.97	0.31	5.96	-	2.91	0.01	12.17	8.49
TN	35.59	7.69	8.01	25.10	0.05	1.01	77.45	9.27
TX	138.09	215.41	0.51	38.44	31.86	6.70	431.02	8.55
UT	30.79	6.40	1.14	-	0.71	0.61	39.65	7.84
VA	14.33	25.13	1.01	28.72	-	1.71	70.90	9.07
VT	-	0.00	1.20	4.99	0.11	0.41	6.71	14.22
WA	3.76	5.49	88.53	9.33	6.69	2.16	115.97	6.94
WI	32.76	11.79	2.02	14.30	1.55	2.07	64.48	10.28
WV	70.30	0.24	1.33	-	1.29	0.18	73.33	8.14
WY	43.64	0.55	0.89	-	4.39	0.33	49.81	7.19
	1,517	1,231	277	769	140	121	4,054	9.84

National Coal Council – Reliable & Resilient: The Value of Our Existing Coal Fleet

APPENDIX D

Reports of the National Coal Council – June 1986-May 2014

National Coal Council – Reliable & Resilient: The Value of Our Existing Coal Fleet

APPENDIX D

Reports of the National Coal Council – June 1986-May 2014



- June 1986** Coal Conversion
Clean Coal Technologies
Interstate Transmission of Electricity
Report on Industrial Boiler New Source Performance Standards
- June 1987** Reserve Data Base: Report of The National Coal Council
Improving International Competitiveness of U.S. Coal and Coal Technologies
- Nov. 1988** Innovative Clean Coal Technology Deployment
- Dec. 1988** Use of Coal in Industrial Commercial, Residential & Transportation Sectors
- June 1990** Industrial Use of Coal and Clean Coal Technology – Addendum Report
The Long Range Role of Coal in the Future Energy Strategy of the United States
- Jan. 1992** The Near Term Role for Coal in the Future Energy Strategy of the United States
Improving Coal’s Image: A National Energy Strategy Imperative
- May 1992** Special Report on Externalities
- Feb. 1993** Role of U.S. Coal in Energy, the Economy & the Environment
A Synopsis of NCC Reports (1986 – 2003)
- Nov. 1993** The Export of U.S. Coal and Coal Technology
- Feb. 1994** Clean Coal Technology for Sustainable Development
- May 1995** Critical Review of Efficient & Environmentally Sound Coal Utilization Technology
- Nov. 1995** The Implications for Coal Markets of Utility Deregulation & Restructuring
- Feb. 1997** Vision 2020: The Role of Coal in U.S. Energy Strategy
- Oct. 1997** Clean Air Act Rules, Climate Change & Restructuring of the Electricity Industry
- Nov. 1998** Coal’s Role in Achieving Economic Growth and Environmental Stability
- May 2000** Research & Development Needs for the Sequestration of Carbon Dioxide
- May 2001** Increasing Coal-Fired Generation Through 2010: Challenges and Opportunities
- May 2003** Coal-Related Greenhouse Gas Management Issues
- Nov. 2004** Opportunities to Expedite the Construction of New Coal-Based Power Plants
- March 2006** Coal: America’s Energy Future (Volumes I & II)
- June 2007** Technologies to Reduce or Capture and Store Carbon Dioxide Emissions

National Coal Council – Reliable & Resilient: The Value of Our Existing Coal Fleet

- May 2008** The Urgency of Sustainable Coal
- Dec. 2009** Low Carbon Coal: Meeting U.S. Energy, Employment & Carbon Dioxide Emission Goals with 21st Century Technologies
- March 2011** Expediting CCS Development: Challenges and Opportunities
- June 2012** Harnessing Coal’s Carbon Content to Advance the Economy, Environment & Energy Security
- May 2014** Reliable & Resilient: The Value of Our Existing Coal Fleet

Reports can be found on the NCC web site at www.nationalcoalcouncil.org

APPENDIX E
Member Roster – 2014

National Coal Council – Reliable & Resilient: The Value of Our Existing Coal Fleet

APPENDIX E

Member Roster – 2014



The National Coal Council
Power for America from America

Robert O. Agbede, President / CEO

Chester Engineers
1555 Coraopolis Heights Road
Moon Township, PA 15108
412-809-6576; Fax: 412-809-6006
ragbede@chester-engineers.com
www.chester-engineers.com

Nicholas K. Akins

Chairman, President & CEO
American Electric Power Company
One Riverside Plaza
Columbus, OH 43215
614-716-3800; Fax: 614-716-1603
nkakins@aep.com

Sy Ali, Principal

Clean Energy Consulting
7971 Black Oak Drive
Plainfield, IN 46168
317-839-6617
sy.ali@cleanenergyconsulting.com

Barbara Farmer-Altizer

Executive Director
Virginia Coal & Energy Alliance Inc.
P.O. Box 339
Lebanon, VA 42266
276-889-4001; Cell: 276-970-5580
Fax: 276-889-3055
barb@virginiacoalenergy.com

Phil Amick, Director

Gasification Business Development
CB&I
Two Riverway, Ste. 1300
Houston, TX 77056
713-375-8013; Cell: 832-641-9536
Phil.Amick@cbi.com

Rodney Andrews, Director

Center for Applied Energy Research "CAER"
University of Kentucky
2624 Research Park Drive
Lexington, KY 40511-8479
859-257-0200; Fax: 859-257-0220
Rodney.andrews@uky.edu

Carol J. Bailey, Sr. Associate

Booz/Allen/Hamilton
1550 Crystal Dr., Ste. 1100
Arlington, VA 22202-4158
703-412-7790; Cell: 703-939-4434
bailey_carol@bah.com; www.bah.com

Richard Bajura, Director

Nat'l Research Center for Coal & Energy
385 Evansdale Drive, Suite 113
Morgantown, WV 26506-6064
304-293-6034; Cell: 304-216-0360
Fax: 304-293-3749;
bajura@wvu.edu; richard.bajura@mail.wvu.edu
www.nrcce.wvu.edu

Theodore K. Barna, Ph.D.

BarnaSolutions LLC
47 Smith Point Circle
Reedville, VA 22539-3053
Cell: 703-568-7492
tbarna2@cox.net

Robert A. Beck

Former NCC Executive Director
& Chair Pittsburgh Coal Conference
335 E. Bluebell Lane
Tempe, AZ 85281
Cell: 703-608-1191
rbeck82851@aol.com

National Coal Council – Reliable & Resilient: The Value of Our Existing Coal Fleet

Janos M. Beer, Prof. of Chemical & Fuel Engineering/
Dept. of Chemical Engineering
Massachusetts Institute of Technology
25 Ames Street Room 66-301
Cambridge, MA 02139
617-253-6661; Fax: 617-252-1651
jmbeer@mit.edu

Robert A. Bibb, P.E., Chairman
Bibb Engineers, Architects & Constructors
3131 Broadway
Kansas City, MO 64111
816-285-5500; Cell 913-961-4477
Fax: 816-285-5555
bobbibb@bibb-eac.com
www.bibb-eac.com

Jacqueline F. Bird
1481 Fahlander Dr N
Columbus, OH 43229
614-846-7498; Cell: 614-218-4427
Jbird1@insight.rr.com

Bill Bissett, President
Kentucky Coal Association
2800 Palumbo Dr., Ste. 200
Lexington, KY 40509
859-233-4743; Fax: 859-233-4745

David C. Boyd, Commissioner & Vice Chair
Minnesota Public Utilities Commission
121 7th Place E., Ste. 350
St. Paul, MN 55101-2147
651-201-2220
David.C.Boyd@state.mn.us

Lisa J. N. Bradley, PhD, DABT,
Vice President and Senior Toxicologist
AECOM
250 Apollo Drive
Chelmsford, MA 01824
978-905-2100
Lisa.bradley@aecom.com

F. William Brownell, Esquire
Hunton & Williams
2200 Pennsylvania Ave. NW
Washington, DC 20006
202-955-1555; Fax: 202-778-2201
bbrownell@hunton.com

Wanda I. Burget
Vice President, Environmental Services
Norwest Corporation
136 East South Temple, 12th Floor
Salt Lake City, Utah 84111
801-539-0044; Fax: 801-539-0055
wburget@norwestcorp.com

Jim Butz
Vice President, Product Management
Novinda Corporation
999 18th Street #1755 North Tower
Denver, CO 80202
720-473-8338; Fax: 720-473-8360
jbutz@novinda.com

Michael Carey, Chairman
Ohio Coal Association
17 South High Street, Suite 640
Columbus, OH 43215-3413
614-228-6336; Fax: 614-228-6349
info@ohiocoal.com
www.ohiocoal.com

Desmond W. Chan, Ph.D.
Manager of Technology
Bechtel Power Corporation
5275 Westview Dr., Frederick, MD 21703
301-228-8764
dchan@bechtel.com

Robert J. Ciavarella, President/CEO
Stock Equipment Company
16490 Chillicothe Rd.
Chagrin Falls, OH 44023
440-543-6000 x276; Cell: 440-724-8096
Fax: 440-543-9416
Robert.ciavarella@stockequipment.com
www.stockequipment.com

Joseph W. Craft, III, President
Alliance Coal
1717 South Boulder Ave.
Tulsa, OK 74119
918-295-7602; Fax: 918-295-7361
josephc@arlp.com

National Coal Council – Reliable & Resilient: The Value of Our Existing Coal Fleet

Michael D. Crotty, President
MKT & Associates, LLC
1776 Mentor Ave, Ste. 402
Cincinnati, OH 45212
513-703-2569;
Mcrotty@MKTassociates.com
15 Dong Ping Rd, Ste. 308,
Shanghai 200031 PRC
Cell: 86 1391 723 9971 (China) Skype:
www.mktassociates.com

Kevin S. Crutchfield, Chairman & CEO
Alpha Resources, Inc.
P.O. Box 16429, One Alpha Place
Bristol, VA 24212
276-619-4441
kcrutchfield@alphanr.com

Christopher C. Curfman, President
Global Mining Division- Caterpillar
300 Hamilton Blvd., Suite 300
Peoria, IL 61629-3810
309-675-5127; Fax: 309-675-4777
Curfman_christopher_c@cat.com
(John Disharoon ~ representative)

Stuart Dalton, Sr. Govt. Rep Generation
Electric Power Research Institute (EPRI)
3420 Hillview Avenue
Palo Alto, CA 94304
650-855-2467
sdalton@epri.com

Jack Daly, Executive Vice President & Director
Fossil Power Technologies
Sargent & Lundy, LLC
55 East Monroe
Chicago IL 60603-5780
Jack.daly@sargentlundy.com

Michael R. DeLallo
Director/Power Business Group
Services and Consulting
CH2M Hill Engineers
11301 Carmel Commons Boulevard
Charlotte, NC 28226
704-544-4040; Direct: 704-543-3085
Cell: 610-507-5189
michael.delallo@ch2m.com

Edward (Ted) Doheny, II
President & CEO
Joy Global Inc.
100 E. Wisconsin Ave., Suite 2780
Milwaukee, WI 53202
(Skip Stephens ~ representative)

George Duggan
Vice President, Coal Marketing
BNSF Railway
2650 Lou Menk Dr., 2nd Floor
PO Box 961057
Ft. Worth, TX 76131-2830
800-795-2673
George.duggan@bnsf.com

Michael D. Durham, President
Advanced Emissions Solutions
9135 S. Ridgeline Blvd., Suite 200
Highlands Ranch, CO 80129
303-737-1727; Fax: 303-734-0330 miked@adaes.com

John Dwyer
7350 162nd Avenue, N.W
Bismarck, ND 58503
701-426-8660
johndwyer@bektel.com

John W. Eaves, President/CEO
Arch Coal, Inc.
1 CityPlace Dr., Ste. 300
St. Louis, MO 63141
314-994-2700; Fax: 314-994-2917
jeaves@archcoal.com

George L. Ellis, President
Pennsylvania Coal Association
212 N. 3rd St, Ste 102
Harrisburg, PA 17101
717-233-7900 ext. 22; Fax: 717-231-7610
ellis@pacoalalliance.com www.pacoalalliance.com

Amy Ericson, U.S. Country President
ALSTOM, Inc.
801 Pennsylvania Ave NW #855
Washington, DC 20004
202-495-4971
Amy.ericson@alstom.com

National Coal Council – Reliable & Resilient: The Value of Our Existing Coal Fleet

Alex G. Fassbender, CEO

Ecovia Corporation
2004 Byrd Rd
Vienna, VA 22182
703-229-9423
alex.fassbender@ecoviacorp.com

Paul J. Feldman, Chairman

Midwest ISO
51 Warwick Stone Way
Great Falls, VA 22066
317-249-5400; Cell: 703-623-1762
PaulFeldman@gmail.com

Robert J. Finley, Director

Advanced Energy Technology Initiative
Illinois State Geological Survey
615 E. Peabody Dr.
Champaign, IL 61820-6964
217-244-8389; Fax: 217-333-2830
finley@illinois.edu

John S. Fischer, CEO

Breakthrough Energy, LLC
1919 14th Street, Suite 609
Boulder, CO 80302
307-682-2529
jfischer@breakthrough-energy.net

David M. Flannery, Member

Steptoe & Johnson, PLLC
P.O. Box 1588, Charleston, WV 25326-1588
Chase Tower, 8th Fl., 707 Virginia St. East
Charleston, WV 25301
304-353-8171; Cell: 304-539-1458
Fax: 304-353-8183
dave.flannery@steptoe-johnson.com

Sarah Forbes, Sr. Associate

World Resources Institute (WRI)
10 G St., NE, Ste. 800
Washington, DC 20002
202-729-7714; Fax: 202-729-7610
sforbes@wri.org

Mark Fraley, Director/Coal Procurement

FirstEnergy Solutions Corporation
341 White Pond Drive
Akron, OH 44320
330-315-6767; Cell: 330-289-1513
fraley@firstenergycorp.com

Robert D. Gabbard, President

PPL EnergyPlus, LLC
2 North 9th Street, GENPL7
Allentown, PA 18101
610-774-4168; Fax: 610-774-6523
RDGabbard@pplweb.com

Dr. Zhongxue Gan, Chief Executive Officer

ENN Intelligent Energy Group
Room 506, Bldg. B, South Xin'ao Science Park,
Xin Yaun St., Hua Lang Fang, China 065001
86-316-259-7051; Fax: 86-316-259-5838
ganzhongxue@enn.cn

Paul Gatzemeier

CBCC
7256 Hwy 3
Billings, MT 59106
406-245-8542; Cell: 406-696-9842
paul.gatzemeier@earthlink.net

Clark D. Harrison

Sr. Mgr./Business Development
CH2M Hill
4697 Logan Ferry Rd
Murrysville, PA 15668
Cell: 412-916-9300
Clark.Harrison@ch2m.com

William Hoback, Deputy Director

IL Office of Coal Development
500 East Monroe
Springfield, IL 62701
217-785-2001; Cell: 217-836-4246
bill.hoback@illinois.gov

Clarence Joseph Hopf

Vice President Wholesale Origination
PPL EnergyPlus, 2 North 9th Street
Mail Code GENPL7
Allen Town, PA 18101
610-774-4548; Cell: 610-709-4451
Fax: 610-774-5141
CJHOPF@pplweb.com

Marty Irwin, Director

IN Center for Coal Tech. Research
1 North Capital, Ste 600
Indianapolis, IN 46204
317-232-8970
mirwin@oed.in.gov

National Coal Council – Reliable & Resilient: The Value of Our Existing Coal Fleet

Daniel R. Jack, Sr. Vice President
Reschini Agency, Inc.
Laurel Place, 922 Philadelphia Street
Indiana, PA 15701
724-349-1300
danjack@reschini.com

Christopher P. Jenkins
Vice President/Coal & Automotive
CSX Transportation
500 Water Street
Jacksonville, FL 32202
904-366-5693; Fax: 904-359-3443
Chris_Jenkins@csx.com

Brian Kalk Ph.D., Chairman
North Dakota Public Service Commission
3208 Chisholm Trail
Bismarck, ND 58503
701-328-2400; Fax: 701-328-2410
bkalk@nd.gov - www.ndpsc.nd.gov

Michael Karmis
Virginia Tech, Mining & Mineral Engineering
100 Holden Hall
Blacksburg, VA 24061
540-231-7057; Fax: 540-231-4070
mkarmis@vt.edu

Norman Kettenbauer
Vice President Engineering & Contracting
GenPower Services LLC & Longview Power LLC
1375 Fort Martin Road
Maidsville, WV 26541
304-599-0930 Ext. 3034
Cell: 304-276-1101
Norman_Kettenbauer@genpower.net

Holly Krutka, Executive Editor
Cornerstone Magazine
Shenhua Science & Tech. Research Institute
7763 South Vine Street
Centennial, CO 80122
Cell: 303-588-4322
hkrutka@yahoo.com

Klaus Lambeck
Public Utilities Commission of Ohio
180 East Broad Street
Columbus, OH 43215-3793
614-764-1295
Klaus.lambeck@puc.state.oh.us

David Lawson, Vice President, Coal
Norfolk Southern Corporation
3 Commercial Place
Norfolk VA 23510
dtlawson@nscorp.com

John T. Long, COO
Connemara Ltd.
10662 Misty Hill Rd
Orland Park, IL 60462
708-205-1930
Jtlong11@gmail.com

Richard P. Lopriore, President
PSEG Fossil LLC
80 Park Plaza, T25A
Newark, NJ 07102-4194
973-430-7533; Fax: 973-643-8229
Richard.lopriore@pseg.com

Thomas Lorenzen, Partner
Dorsey & Whitney, LLP
1801 K St. NW, Ste. 750
Washington, DC 20006
202-442-3525; Fax: 202-442-3199
Lorenzen.thomas@dorsey.com

Jason Makansi, President
Pearl Street, Inc.
3963 Flora Place, 2nd Floor
St. Louis, MO 63110
314-495-4545
jmakansi@pearlstreetinc.com
www.pearlstreetinc.com

Daniel T. Martin, Sr. Vice President
Sales/Customer Service
Ingram Barge Company
One Belle Meade Pl, 4400 Harding Rd.
Nashville, TN 37205-2290
615-298-8373; Fax: 615-298-8213
martind@ingrambarge.com

John S. Mead
Former Director
SIU Coal Research Center
11101 North Pomegranate Dr.
Oro Valley, AZ 85737
618-521-4270
jmead@siu.edu

National Coal Council – Reliable & Resilient: The Value of Our Existing Coal Fleet

Emmanuel R. Merle, President
Energy Trading Company
15 East Putnam Avenue, #3210
Greenwich, CT 06830
203-618-0161; Fax: 203-618-0454
thion@mindspring.com

Jeffrey Miller, Production Services Manager *Luxottica Retail*
4199 Silver Streak Drive
Cincinnati, OH 45245
513-765-6678
jmiller@luxotticaRetail.com

Rafic Y. Minkara
Vice President/Technology
Headwaters, Inc.
204 Lakeside Dr.
Kennesaw, GA 30144
770-330-0689
rminkara@headwaters.com

Nancy Mohn, Director/Marketing Strategy
ALSTOM
2000 Day Hill Road
Windsor, CT 06095
860-285-5748; Fax: 860-285-9991
nancy.c.mohn@power.alstom.com

Betsy B. Monseu, CEO
American Coal Council
1101 Pennsylvania Avenue, NW #600
Washington, DC 20004
202-756-4540
bmonseu@americancoalcouncil.org

Clark A. Moseley, President & CEO
The Morrow-Pacific Project/Ambre Energy
1211 SW Fifth Ave., Ste. 700
Portland, OR 97204
503-224-3352; Cell: 214-275-5785
c.moseley@ambreenergy.com

Michael G. Mueller
Vice President Energy Mgt. & Trading
Ameren Missouri
1901 Chouteau Avenue
St. Louis, MO 63103
314-554-4174; Fax: 314-206-1250
mmueller@ameren.com

Georgia Nelson, President and CEO
PTI Resources, LLC
401 N. Wabash Ave., #42A
Chicago, IL 60611
262-248-8373; Cell: 312-286-9393
geopti@aol.com

Kenneth J. Nemeth, Executive Director
Southern States Energy Board
6325 Amherst Court
Norcross, GA 30092
770-242-7712; Fax: 770-242-0421
nemeth@sseb.org

Mary Eileen O'Keefe, President & CEO
Lake Shore International, Ltd.
1362 N. State Parkway
Chicago, IL 60601
312-482-9701; Cell: 312-420-4094
Fax: 312-482-9703
maryeileenokeefe@aol.com

Jerry J. Oliver, President
Global Tech Management Services
9519 Tarrant Court
Houston, TX 77064
Cell: 832-661-5103
jjoliver826@aol.com

Fredrick D. Palmer, Sr. Vice President
Peabody Energy
701 Market St.
St. Louis, MO 63101-1826
314-342-7624; Fax: 314-342-7614
fpalmer@peabodyenergy.com

Ronald W. Pircon, President/CEO
Benetech
2245 Sequoia Rd., Ste. 300
Aurora, IL 60506
630-844-1300; Fax: 630-806-7253
pirconr@benetechusa.com

Robert M. Purgert, President
Energy Industries of Ohio
Park Center Plaza, Suite 200
6100 Oak Tree Blvd.
Independence, OH 44131
216-643-2952; Fax: 216-643-2901
purgert@energyinohio.com

National Coal Council – Reliable & Resilient: The Value of Our Existing Coal Fleet

Randall L. Rahm, President
CoalTech Consultants, Inc.
6800 NE Indian Creek Rd.
Topeka, KS 66617
785-249-3981; Fax: 785-246-0959
rrahm1@cox.net

Massood Ramezan, PhD, PE
Sr. Technical Advisor/Div. Director
Leonardo Technologies Inc. (LTI)
M/S B922, P.O. Box 10940
Pittsburgh, PA 10940
412-386-6451; Cell: 724-554-3596
mramezan@lti-global.com

William Raney, President
West Virginia Coal Association
PO Box 3923
Charleston, WV 25339
304-342-4153
braney@wvcoal.com

Bill Reid, Managing Editor
Coal News
106 Tamarack Street
Bluefield, WV 24701-4573
304-327-6777; Fax: 304-327-6777
billreid007@comcast.net

Frederick M. Reuter, III
21 East 11th St.
Covington, KY 41011
859-291-7044; Fax: 859-291-1939
Fmreuter3@fuse.net

Todd Savage
Executive Vice President/Group Leader
Savage Companies
901 W. Legacy Center Way
Midvale, UT 84047
801-944-6600
info@savageservices.com
www.savageservices.com

Mark Schoenfield, Sr. VP/Operations
Jupiter Oxygen Corporation
4825 North Scott Street, Ste. 200
Schiller Park, IL 60176
219-712-5206; Fax: 847-928-0795
M_schoenfield@jupiteroxygen.com

Debra L. Schumacher, President
Women In Mining
915 Mayfair Dr.
Booneville, IN 47601-2319
812-749-0040
wolfie66@msn.com
dschumacher@peabodyenergy.com

John J. Siegel, Chairman
Bowie Resource Partners, LLC
6100 Dutchmans Lane, 9th Floor
Louisville, KY 40205
502-584-6022; Fax: 502-587-6579
www.bowieresources.com

Michael J. Sierra, President
The Ventura Group, Inc.
44675 Cape Court, Unit 150
Ashburn, VA 20147
703-208-3303; Fax: 703-208-3305
msierra@theventuragroup.com

Michael G. Sorensen
Sr. Mgr. Fuel & Water Resources
Tri-State Generation & Transmission Assn., Inc.
P.O. Box 33659
Denver, CO 80233-0695
303-254-3208; Cell: 303-229-5039
mgsorensen@tristategt.org

William J. Spengel, Sr. VP/Fossil Operations
URS – Washington Division
510 Carnegie Center
Princeton, NJ 08540
609-720-2560; Cell: 609-937-2902
Fax: 609-720-2280
bill.spengel@wgint.com

David F. Surber
Syndicated Environmental TV Journalist
PO Box 15555
Covington, KY 41015-0555
859-491-5000; Fax: 859-291-5000
surber@surber.com

Daniel Thompson
Vice President and General Manager
Dynegy Midwest Generation, LLC
604 Pierce Boulevard
O'Fallon IL 62269
618-206-5918
Daniel.P.Thompson@dynegy.com

National Coal Council – Reliable & Resilient: The Value of Our Existing Coal Fleet

John W. Thompson, Director
Fossil Transition Project, Clean Air Task Force
705 W. Main St., Suite 101
Carbondale, IL 62901
618-457-0137; Cell: 618-203-6233
Fax: 618-457-0513
jthompson@catf.us;
www.catf.us; www.fossiltransition.org

Pamela Tomski, Sr. Advisor
Policy and Regulatory, The Americas
Global CCS Institute
1358 Perry Place NW
Washington DC 20010
202-390-8896
ptomski@mac.com

David D. Turnbull, CEO
Hillsborough Resources Limited
1090 W. Georgia St., Suite 950
Vancouver, BC V6E 3V7 Canada
604-684-9288 ext. 222; Cell: 604-910-1845
US Cell: 304-859-7588
ddt@hillsboroughresources.com

Daman S. Walia, President/CEO
ARCTECH, Inc.
14100 Park Meadow Dr.
Chantilly, VA 20151
703-222-0280
dwalia@archtech.com
www.archtech.com

Kathy Walker, President
Elm Street Resources, Inc.
P.O. Box 1718
Paintsville, KY 41240
606-789-4036 Ext. 14
kwelmst@bellsouth.net

Jeffrey L. Wallace
Vice President Fuel Services
Southern Company Services
6000 North 18th St., 14N-8160
Birmingham, AL 35203
205-257-6111
jlwallac@southernco.com

Kathy Walton, Principal
The Basic Industries Group, LLC
1407 Second Ave., Suite 3A
New York, NY 10021
917-836-2000
kw Walton@thebasicindustries.com

Richard M. Whiting, President
Kinder Morgan Resources, LLC
7733 Forsyth Blvd., Suite 1100
St. Louis, MO 63105
Richard_Whiting@kindermorgan.com

Jennifer Wilcox, Assistant Professor
Stanford University/Energy Resources Engineering
367 Panama Street
Stanford, CA 94305
650-724-9449; Fax: 650-725-2099
wilcoxj@stanford.edu
www.cec-lab.stanford.edu

Robert Williams
Sr. Research Scientist & Associated Faculty
Princeton Environmental Institute
Princeton University
140 Guyot Hall, Washington Road
Princeton, NJ 08544
609-258-5448
rwilliam@princeton.edu

Kemal Williamson, President, Americas
Peabody Energy
701 Market Street, Suite 1400
St. Louis, MO 63101
kwilliamson@peabodyenergy.com

Gregory A. Workman, Director/Fuels
Dominion Resources
120 Tredegar Street – DC3
Richmond, VA 23219
804-787-5702
greg.workman@dom.com

National Coal Council – Reliable & Resilient: The Value of Our Existing Coal Fleet

NCC STAFF

Janet Gellici, Executive Vice President/COO

1730 M Street NW, Ste. 907

Washington, DC 20036

202-223-1191; Cell: 602-717-5112

Fax: 202-223-9031

jgellici@NCC1.org

Hiranthie Stanford

Membership & Meetings Manager

1730 M Street NW, Ste. 907

Washington, DC 20036

Cell: 202-765-4349

Fax: 202-223-9031

hstanford@NCC1.org

LEGAL COUNSEL

Karen Bennett, Counsel

Hunton & Williams LLP

2200 Pennsylvania Ave. NW

Washington, DC 20006

202-955-1958; Fax: 202-828-3743

kbennett@hunton.com

APPENDIX F
Dissenting Opinion

May 29, 2014

The Honorable Dr. Ernest Moniz
U.S. Secretary of Energy
U.S. Department of Energy
1000 Independence Avenue, SW
Washington, D.C. 20585

RE: Reasons for My Dissenting Vote on the National Coal Council Report
“Reliable & Resilient, The Value of Our Existing Coal Fleet: An Assessment of Measures
to Improve Reliability & Efficiency While Reducing Emissions”

Dear Mr. Secretary:

The National Coal Council’s report, “Reliable & Resilient, The Value of Our Existing Coal Fleet: An Assessment of Measures to Improve Reliability & Efficiency While Reducing Emissions” (“NCC Report”) provides some valuable information on the importance of the U.S. coal fleet and the challenges it faces. But in other respects it is non-responsive to the charge you made to the group, namely to address the question: “What can industry and the Department of Energy, separately and jointly, do to facilitate enhancing the capacity, efficiency and emissions profiles of the existing coal generation fleet in the United States through application of new and advanced technology?” Instead, the Report too often describes what the industry believes can’t be done, rather than what we can and must do, to achieve reliable baseload generation as well as the public health and climate objectives that are central to our country’s healthy future. I do not consider the Report responsive to your charge, and for that reason, and as more specifically detailed in this letter, I dissented from the vote adopting this Report at the last National Coal Council meeting.

Our world is changing now – significant damage already is occurring as a result of climate change caused by manmade emissions of greenhouse gases. As the National Climate Assessment notes, “Global climate is changing and this is apparent across the United States in a wide range of observations. The global warming of the past 50 years is primarily due to human activities, predominantly the burning of fossil fuels.”¹ This is the context within which continued reliance on the existing coal fleet must be considered.

In order to ensure that the U.S. can continue to rely on fossil fuels for baseload electricity generation, currently available and new greenhouse gas controls – particularly carbon capture and sequestration, the best developed such control for the power sector – must be rapidly advanced. But the NCC Report belittles the viability of carbon capture and storage (“CCS”) technology today. It omits solutions that could speed the retrofit of CCS technology now on many plants in the existing fleet, and as a result, fails to describe the potential long-term value of the existing coal fleet in advancing the President’s climate objectives. Moreover, the Report also shortchanges the significant public health benefits to be realized by a modernized, better-controlled existing coal fleet. It is not enough to say that uncontrolled coal plants have historically provided inexpensive baseload power, without also discussing the public health costs associated with that historical behavior. Nor is the Polar Vortex event sufficient justification for the industry to avoid its obligations to achieve required

¹ U.S. National Climate Assessment, US Global Change Research Program, *Climate Change Impacts in the United States*, May 2014, 15.

further public health and climate improvements. Indeed, the NCC Report in many places seems purposely intended to undermine such continued improvements, containing misleading assertions about the Polar Vortex event. Mr. Secretary, I won't detail in this letter each and every factual point I disagree with in the NCC Report, but I will lay out below my concerns about several significant issues that led me to vote "no" on forwarding the NCC Report to you.

1. CCS Technology is Available and Adequately Demonstrated for New and Retrofit Applications

Retrofitting CCS on existing fossil fuel-fired power plants -- particularly on the existing coal fleet, which is the subject of the NCC Report, is essential if the worst climate change impacts are to be avoided. And this is possible. A 2011 DOE NETL study found that 85 percent of the existing coal fleet was potentially suitable for CCS retrofit.²

By contrast, the NCC Report makes several erroneous findings about CCS including that it "has yet to be demonstrated," is not currently a "viable technology," that EOR storage and carbon saline sequestration have limited knowledge base and that "12 large scale carbon capture projects are needed to adequately demonstrate CCS."³

These statements are incorrect, and they seem purposely intended to undermine the Environmental Protection Agency's ("EPA's") efforts to set meaningful new and existing source performance standards based in some part on this technology. In fact, "adequately demonstrated" is a legal term of art under the Clean Air Act, and CCS technology more than meets this standard.⁴ "Adequately demonstrated" does not require that twelve existing sources deploying a particular control technology be in existence before that technology can form the basis for a performance standard;⁵ or even that the technology be in active use in the industry at the time of the rulemaking.⁶ Instead, the EPA Administrator is to look at the state of technology now and out to the future, to make a reasonable projection of availability of controls in setting standards for a particular industry.⁷

² Global CCS Institute, "What to do with existing coal-fired electricity generation plants" (Nov. 8, 2013), *available at*: <http://www.globalccsinstitute.com/insights/authors/davidhanly/2013/11/08/what-do-existing-coal-fired-electricity-generation-plants>.

³ NCC Report at 6, 89.

⁴ Performance standards for stationary sources are set to reflect "the degree of emission limitation achievable through the application of the best system of emission reduction which (taking into account the cost of achieving such reduction and any nonair quality health and environmental impact and energy requirements) the Administrator determines has been *adequately demonstrated*." 42 U.S.C. § 7411(a)(1) (emphasis added).

⁵ *Nat'l Asphalt Pavement Ass'n v. Train*, 539 F.2d 775, 785-86 (D.C. Cir. 1976).

⁶ *See Portland Cement v. EPA (Portland Cement I)*, 486 F.2d 375, 391 (D.C. Cir. 1973).

⁷ *Portland Cement I*, 486 F.2d at 391-92 (citing and quoting *Int'l Harvester v. Ruckelshaus*, 478 F.2d 615, 629 (D.C. Cir. 1973)). My specific views on CCS readiness for new sources within the fossil-fuel fired power plant fleet are detailed in comments submitted by the Clean Air Task Force in the docket for EPA's proposed 111(b) CO₂ emission limits. *See* Doc. No. EPA-HQ-OAR-2013-0495-9664.

As you well know, integrated CCS systems are now, and will be available for commercial application on existing coal-fired power plants. Further, the component elements of these systems have been in long-standing use in other similar industrial applications in the U.S. and abroad. Several CCS retrofit projects are moving forward, many of which the NCC Report outlines. The Report, however, downplays the significance of these projects calling them limited in scope or in authentic experience. See NCC Report at Appendix B. But, the Clean Air Act allows -- even demands -- EPA to "extrapolat[e] . . . a technology's performance in other industries," and look beyond domestic facilities to those used abroad.⁸ The Global CCS Institute maintains a list of integrated CCS projects, including a number of current retrofit CCS projects on coal and gas fired power plants.⁹

The NCC Report fails to mention decades of commercial CCS experience in industrial settings such as natural gas cleaning, refinery operations and fertilizer production. It fails to mention CCS experience on flue gas from burning natural gas. It fails to describe decades of pre-combustion capture experience in coal gasification settings. As a result, the Report fails to consider the transferability of this extensive expertise and experience to the power sector and the coal sector in particular.

These omissions are material and contribute significantly to the NCC Report's failure to respond to your charge by accurately describing CCS as ready now for deployment on existing coal plants, and then discussing what steps need to be taken to facilitate that process.

If we are to meet the President's climate goals, our country must move towards controlling the carbon emissions from the existing power plant fleet now, including through CCS retrofits in appropriate situations. Two changes must take place. First, regulations must signal that CO₂ reductions from the existing fleet are required, and second, new or expanded financial programs must be established to help pay for the needed retrofits. These conditions are explored below.

a. Regulations to Support CCS Deployment

Next week, EPA will announce new CO₂ emission restrictions aimed at curbing the existing power plant's emissions under 111(d). It is important to note that the U.S. is not alone in establishing coal-fired power plant emission restrictions. In 2012, Canada finalized regulations that set new CO₂

⁸ *Lignite Energy Council v. EPA*, 198 F.3d 930, 933-34 & n.3 (D.C. Cir. 1999).

⁹ Global CCS Institute, "Large-Scale Integrated CCS Projects," <http://www.globalccsinstitute.com/projects/browse>.

emission limits for both existing and new coal plants.¹⁰ And a retrofit CCS project on an existing coal fired power plant is scheduled to begin operations in 2014.¹¹

The importance of EPA regulations limiting CO₂ to a utility's ability and willingness to undertake CCS as a control option is illustrated by the July 2011 statements of AEP's then-CEO Mike Morris, about the company's decision to table efforts to advance CCS on the Mountaineer power plant after failing to win approvals from the state's economic regulators.¹²

"We are clearly in a classic 'which comes first?' situation," Morris said. "The commercialization of this technology is vital if owners of coal-fueled generation are to comply with potential future climate regulations without prematurely retiring efficient, cost-effective generating capacity. But as a regulated utility, it is impossible to gain regulatory approval to recover our share of the costs for validating and deploying the technology without federal requirements to reduce greenhouse gas emissions already in place. The uncertainty also makes it difficult to attract partners to help fund the industry's share."

DOE can play an important role in working with EPA, sharing its experience with Mountaineer and other projects to ensure that EPA's final performance standard rules and guidelines can enable power companies to justify retrofits on existing plants to both investors and regulators.

2

¹⁰ On September 12, 2012, Canada's Minister for the Environment published final CO₂ performance standards applicable to both new coal-fired EGUs and to coal-fired units that have reached the end of their useful lives. *Reduction of Carbon Dioxide Emissions from Coal-fired Generation of Electricity Regulations*, SOR/2012-167 §§ 3(1), 2 (definitions of "old unit" and "useful life"), 146 C. Gaz. II, 19 (Sept. 12, 2012) available at: <http://www.gazette.gc.ca/rp-pr/p2/2012/2012-09-12/html/sor-dors167-eng.html> [hereinafter, "Canadian Rule"]. The standard, promulgated under the Canadian Environmental Protection Act of 1999, is set at an emissions rate of 420 metric tons per gigawatt hour (GW-hr), a rate equivalent to 925.10 lbs/MWh (partial net), comparable to EPA's proposal. The Environment Ministry states that this rate is based on "the emissions intensity level of NGCC technology," Backgrounder 2012-09-05, Canadian Rule, available at: <http://www.ec.gc.ca/default.asp?lang=En&n=5C4438BC-1&news=D375183E-0016-4145-A20B-272BDB94580A>. The Canadian Rule provides for a temporal exemption until 2025, which may be sought by new and end-of-life units that use CCUS technologies to meet the performance standard.

¹¹ The Boundary Dam project, in Saskatchewan, will retrofit post-combustion capture to a 110 MW existing coal-fired electric generating unit (EGU) (Unit 3 at Boundary Dam Power Station). SaskPower, "Boundary Dam Integrated Carbon Capture and Storage Demonstration Project," http://www.saskpower.com/sustainable_growth/assets/clean_coal_information_sheet.pdf. It is scheduled to begin commercial operation in 2014, and will sequester through enhanced oil recovery operations approximately 90 percent of the CO₂ from the 110 MW unit or approximately 1 million tons per year.

¹² "AEP, "AEP Places Carbon Capture Commercialization On Hold, Citing Uncertain Status Of Climate Policy, Weak Economy," *AEP News Release*, July 11, 2014.

b. Costs of CCS Retrofits Need Not and Must Not Be a Barrier to CCS Deployment

The NCC Report does discuss technology innovation to lower costs and improve performance, but in so doing fails to note that although ensuring that new plants install new technology is important, that does not mean that existing coal plants should not also begin to install CCS technology now.¹³ Indeed, while the Report correctly notes that the past few decades have seen rapid advancement in conventional pollution controls on this industry, and corresponding rapid and deep reduction in pollutants like SO₂, NO_x, and particulate matter, it does not at the same time accurately assess the potential for the same trajectory for carbon pollution reductions from this industry. Indeed, the NCC Report tends to describe the role of CCS in the existing fleet as some distant event that takes place after many decades and much technology innovation. In fact, deep reductions occurred with some speed from the point at which the retrofit technology was available for installation (as CCS technologies are today). During the first 25-year time period that started in 1980, sulfur emissions dropped 30 percent, mostly as utilities switched from high-sulfur coals to low-sulfur coals. Scrubbers were installed during this 25-year period, but the dominant control measure was fuel switching. In 2005, sulfur emissions fell an additional 30 percent, but this time the reduction was achieved in only 5 years – and it was due to wide installation of scrubbers on the existing US coal fleet. Where we were in the early 2000s is close to where we are today with CCS technologies, for existing facilities located near sequestration resources.

Retrofitting existing coal-fired power plants may be a least cost option for avoiding the worst effects of climate change. Contrary to the NCC Report's assertion,¹⁴ the capital cost of CCS retrofits is *not* a barrier to their deployment. Construction and operating costs associated with CCS technologies will decrease as further experience with them is gained in response to the standard.¹⁵ This is supported by statements that SaskPower plans to retrofit additional units with CCS after Boundary Dam and expects the next retrofit will cost 30 percent less in capital costs and 20 percent less in operating costs.¹⁶

¹³ Under the Clean Air Act, EPA's standards must be "reasonably reliable, reasonably efficient, and . . . reasonably . . . expected to serve the interests of pollution control *without becoming exorbitantly costly in an economic or environmental way.*" *Essex Chemical Corp. v. Ruckelshaus*, 486 F.2d 427, 433 (D.C. Cir. 1973) (emphasis added). A standard that promotes some CCS retrofits on existing coal-fired power plants meets this directive.

¹⁴ NCC Report at 82.

¹⁵ See generally Nicholas A. Ashford, et al., "Using Regulation to Change the Market for Innovation," 9 Harv. L. Rev. 419 (1985) (providing several examples of industry response to new regulation where the industry creates new technology and a market niche yet product change occurs rapidly as technology improves in order to compete on the basis of price). See also Margaret R. Taylor, et al., "Regulation as the Mother of Innovation: The Case of SO₂ Control" 27 Law & Pol'y 348 (Apr. 2005) (using the history of SO₂ control to show that increased diffusion of technology results in significant and predictable operating cost reduction in existing systems, as well as notable efficiency improvements and capital cost reductions in new systems).

¹⁶ Graham Lanktree, "Nothing Ventured, Nothing Recovered: SaskPower's Boundary Dam Project a Test Case for Carbon Capture and Storage," CIM Magazine (Mar./Apr. 2014), available at: <http://magazine.cim.org/en/2014/March-April/special-report/Nothing-ventured-nothing-recovered.aspx>; See e.g. also, Meg Alexander, "Refrigeration Could Cool Down Costs of Carbon Capture and Storage," GizMag (Apr. 22, 2014), available at: <http://www.gizmag.com/sintef-refrigeration-carbon-capture-storage/31718/>. "New research by Scandinavian research organization Sintef has found that refrigeration technology may reduce costs [of CCS] by up to 30 percent, increasing the potential for faster implementation." *Id.*

Moreover, the costs of existing CCS technology can be managed with a series of incentives – and the Department of Energy can be instrumental in this regard. In combination with EPA 111(d) standards, incentives could make retrofit existing coal plants attractive to some power companies. These incentives include:

- Tax-exempt financing. Tax-exempt financing played a central role in deploying coal-fired power plant conventional pollution controls such as scrubbers and NO_x controls. If significant tax-exempt financing were to be made available for CCS retrofits, it could lower the cost of capital by 2 percent or more. Given that CCS technology is inarguably capital intensive for both coal and gas plants, such a lower interest rate, coupled with longer repayment times, could reduce LCOE by tens of \$/MWh on both coal and gas equipped with CCS. DOE could draw upon its decades of understanding how tax-exempt financing played a key role in pollution control deployment in the past to identify the kinds of financing programs to advance CCS retrofits.
- EOR incentives. Revenue generated by the sale of captured CO₂ for use in enhanced oil revenue significantly reduces costs associated with CCS. Whether implemented on a new plant or as a retrofit, using EOR to sequester the captured carbon dioxide can add as much as \$40/ton in revenue to a CCS project. Incentives for using anthropogenic CO₂ in EOR could add to this amount, lowering LCOE of CCS equipped coal and gas plants. Depending on the scale of the program, these incentives could be worth tens of \$/MWh on both coal and gas CCS plants. Working together, industry and DOE could help identify options for these incentives that are both affordable and increase domestically produced transportation fuels.

Further, the NCC Report overlooks some key cost advantages of the existing fleet with respect to CCS retrofits. These include that the existing fleet is extensive and already largely fully paid for and depreciated. And, the time it takes to retrofit an existing plant is much shorter than the time needed to build a new plant with CCS. While challenged by advancing age and competition from abundant, low cost of natural gas, incentives can help overcome these challenges to speed CCS retrofits on existing plants.

c. Compliance with Subpart RR Will Not Deter EOR Operators from Purchasing Captured CO₂

The NCC Report asserts that there is uncertainty surrounding whether electric generating unit operators, if they are required to demonstrate that captured CO₂ is sent to a facility reporting under Clean Air Act Greenhouse Gas Reporting Rule subpart RR, will choose the cost advantageous EOR sequestration. NCC Report at 10, 88. While some EOR operators have baldly asserted that if they are required to comply with subpart RR, that would cause them to avoid the purchase of captured CO₂, I do not agree.

First, it is not inconsequential that available sources of naturally mined CO₂ are declining, and that there is therefore a significant demand for anthropogenic CO₂ in this industry.¹⁷ Specifically, a

¹⁷ See V. Kuuskraa, Advanced Resources International, Inc., “Using the Economic Value of CO₂- EOR to Accelerate the Deployment of CO₂ Capture, Utilization and Storage (CCUS),” in *Proceedings from the 2012 CCS Cost Workshop*, Global CCs Institute (April 25-26 2012) at slide 9, available at <http://cdn.decaboni.se/sites/default/files/publications/100356/proceedings-2012-costs-workshop.pdf>.

2012 analysis found that the economic demand is for 25 billion metric tons of CO₂, as compared with current available volumes of about 3 billion metric tons from natural resources, and existing natural gas processing facilities.¹⁸ The additional anthropogenic CO₂ supply is estimated to represent a \$1 trillion market (less costs of CO₂ transportation). It seems unlikely that existing operators would prefer to go out of business rather than access this market, simply because of the need for better reporting of the amounts of CO₂ managed in EOR activity.

Second, the costs of opting in to subpart RR reporting by an existing EOR operator with a Class II permit are simply not significant, particularly when compared to the potential revenue from the sale of the produced oil, a calculation EPA performed in the Economic Impact Analysis for the Subpart RR rules.¹⁹ When EPA compared the average annualized costs of meeting the RR requirements at an EOR field with a Class II UIC permit, to the estimated revenue per field, the resulting “cost/sales ratio” ranged from 3.1-4 percent.²⁰ The cost per field is estimated to be on the order of \$2 million dollars per year for the full monitoring and reporting program. As compared not just with the expected revenue to the operator, but also the cost to the environment of unmonitored, unreported (and therefore unknown and unchecked) CO₂ leakage to the atmosphere, this cost is reasonable.

2. The Long-Term Value of the Existing Coal Fleet is Inextricably Linked to Providing Low-Carbon Base Load Power Through CCS Retrofits.

The NCC Report correctly notes that the historical value of the existing coal fleet has been providing low cost, base load power. This role is the basis for the NCC Report’s many descriptions of coal’s economic benefits to the US economy. But uncontrolled coal plants also present costs to the economy, in the form of public health and climate damage.²¹ If the existing coal fleet is to continue to provide this base load function for many decades to come, we must adjust its mission to the new reality – which is the implementation of long-overdue conventional air pollution controls, and action to address coal plants’ contribution to the damage caused by global warming pollution.

Specifically, the existing coal fleet must, over time, be retrofit with CCS to provide the United States with a backbone of sustainable, low-carbon base load power. This backbone should not be limited to just coal with CCS, but must include gas power plants with CCS controls, and nuclear power too, if we are to achieve our climate objectives and maintain the reliable electricity system we have enjoyed to date.

An “all of the above” approach to providing this reliability can enable deep CO₂ cuts by mid-century, which otherwise will be significantly impaired and needlessly costly. Low-carbon base load

¹⁸ *Id.*

¹⁹ See 75 Fed. Reg. 75,060, 75,072-75,074 (Dec. 10, 2010) & Economic Impact Analysis for the Mandatory Reporting of Greenhouse Gas Emissions Subpart RR: Proposed Carbon Dioxide Injection and Geologic Sequestration Reporting Rule, EPA-HQ-OAR- 2009-0926-0830 §§ 4.5-4.10, 5.3-5.4, Tables 5-8 & 5-9.

²⁰ *Id.* § 5.4, Tables 5-8 & 5-9.

²¹ See, e.g. Clean Air Task Force, *Power to Kill: Death and Disease from Power Plants Charged with Violating the Clean Air Act*, (July 2001), available at: [http://www.catf.us/resources/publications/files/Power to Kill.pdf](http://www.catf.us/resources/publications/files/Power%20to%20Kill.pdf).

power reduces total system integration costs for clean, variable resources such as wind and solar. Integration includes several items: profile costs (to accommodate the fluctuating output of intermittent sources), balancing costs (to address output uncertainties) and grid costs. As wind and solar reach higher levels of system penetration, these costs become more significant. One European study estimates the integration costs of wind above 20 percent system penetration exceed the cost of generating electricity from wind.²² In another study, Idaho Power estimates the cost of integrating wind at 11 percent penetration at 17 dollars/MWH and 16 percent penetration at 50 dollars/MWH.²³ Other studies report lower integration costs, but integration in these studies does not include the costs of back-up capacity.

“All of the above” is more than just a slogan for describing a path for achieving GHG reductions. It allows the electric system as a whole to be optimized. CCS retrofits on the existing fleet provide an essential element of this approach – allowing wind and solar resources to be integrated within an important, but likely range of 25-30 percent within the system. And it supports continued system reliability.

The NCC Report, however, diverts attention from this function of the existing coal fleet, instead repeating warnings about a future in which the existing fleet is better controlled for both its conventional and its climate pollution emissions. These statements are misleading. While I do not mean to minimize the important role played by the existing coal fleet in assuring system reliability during the recent Polar Vortex event, that experience does not justify failing to continue to move forward with needed modernization and additional pollution controls.

3. The Polar Vortex Does Not Justify Weakening Environmental Regulations in an Attempt to Preserve Small, Aging Coal Plants.

In January and February 2014, the Polar Vortex, a weather phenomenon generally confined to the Arctic, made its way into much of North America. The extreme weather increased demand on our electric system and older coal plants, some of which are scheduled for retirement, were relied on heavily. The NCC Report takes the position that “[o]nly the availability and operation of coal units now scheduled for retirement over the next two years enabled the power sector to meet demand during periods of harsh weather events,” and that “the U.S. power grid is less resilient than previously believed.” NCC Report at 16. This is an overstatement. Terry Boston, President and CEO of PJM, the world’s largest competitive wholesale energy market, recently stated:

...we are still in the midst of the largest fuel switch in history and managing the retirement of 26,000 megawatts of coal generation – largely being replaced by new natural gas plants, demand response and transmission upgrades. Many remain skeptical about this fuel transition, but PJM and our members are navigating this challenge. Next year our reserve margins will be tighter, but the PJM system will be reliable – meeting all NERC standards.²⁴

²² Falko Ueckerdt, et.al, *System LCOE: What are the Costs of Variable Renewables?* Paris, 32th International Energy Workshop, June 20, 2013.

²³ Idaho Power, Wind Integration Study Report, February 2013.

MISO, the regional transmission organization serving the Midwest also recently reported that it will meet demand in the coming years.²⁵

Further, older coal plants were only relied upon during the Polar Vortex event because of an unusual number of exceptional events occurring at other plants.²⁶ These events were generally weather-related, operational, and mechanical failures and will be fixed going forward.²⁷ Grid operators will require testing to ensure that plants will not have difficulty coming online after periods of dormancy.²⁸ They will also improve generator availability and performance during extreme weather events; implement performance verification or testing of generation in advance of winter operations; implement market mechanisms that encourage better generator availability, such as incentives for ensuring fuel availability or dual-fuel capability; and review the cost allocation for uplift charges and investigate a mechanism to allocate uplift costs during emergency operations that minimizes volatility.²⁹

Additionally, even though there was sufficient natural gas to meet demand, procurement practices stalled effective market response.³⁰ FERC is currently proposing a series of "small market fixes" to lessen the volatility in the price of electricity and natural gas during extreme cold events.³¹ The proposed orders will better coordinate the scheduling of natural gas and electricity markets in light of increased reliance on natural gas for power generation.³²

²⁴ Terry Boston, President and CEO, Prepared Remarks at the PJM Annual Meeting (May 15, 2014) *available at*: <http://www.pjm.com/~media/documents/presentations/20140515-terry-boston-2014-annual-meeting-prepared-remarks.ashx>. See also PJM Interconnection, *Analysis of Operational Events and Market Impacts During the January 2014 Cold Weather Events*, (May 8, 2014), *available at*: <http://www.pjm.com/~media/documents/reports/20140509-analysis-of-operational-events-and-market-impacts-during-the-jan-2014-cold-weather-events.ashx> (explaining that grid reliability was maintained).

²⁵ MISO, Press Release, "MISO Clears Second Annual Capacity Auction" (Apr. 15, 2014) *available at*: <https://www.misoenergy.org/AboutUs/MediaCenter/PressReleases/Pages/MISOClearsSecondAnnualCapacityAuction.aspx>.

²⁶ John Moore and Allison Clements, Sustainable FERC Project, "The Polar Vortex and the Power Grid: What Really Happened and Why the Grid will Remain Reliable without Soon-to-Retire Coal Plants," (Apr. 29, 2014) *available at*: <http://sustainableferc.org/the-polar-vortex-and-the-power-grid-what-really-happened-and-why-the-grid-will-remain-reliable-without-soon-to-retire-coal-plants/>.

²⁷ *Id.*

²⁸ *Id.*

²⁹ PJM Interconnection, *Analysis of Operational Events and Market Impacts During the January 2014 Cold Weather Events*, (May 8, 2014), *available at*: <http://www.pjm.com/~media/documents/reports/20140509-analysis-of-operational-events-and-market-impacts-during-the-jan-2014-cold-weather-events.ashx>

³⁰ *Id.*

³¹ Rod Kuckro and Hannah Northy, "Federal Regulators Aim to Fix Power Markets by Next Winter," *Energywire* (Apr. 3, 2014) *available at*: <http://www.eenews.net/energywire/stories/1059997226>

³² Coordination of the Scheduling Processes of Interstate Natural Gas Pipelines and Public Utilities, 79 Fed. Reg. 18,223 (Apr. 1, 2014) (Notice of Proposed Rulemaking).

The NCC Report further makes several misleading statements that distort the effect and lessons of the Polar Vortex:

- The Report compares the sources of electricity generation in 2012 and 2013 with 2014, however 2012 was the warmest winter in 80 years, resulting in very low gas prices and low coal generation. NCC Report at 11-12. Using 2012, and to a lesser extent 2013, as a basis for comparison with the very cold winter of 2014 will yield incorrect conclusions with respect to coal generation and gas prices.³³
- The Report cites America Electric Power's claim that "[n]atural gas delivery is challenged. NCC Report at 13. However, the high prices and limitations on gas delivery to gas-based generation with interruptible service occurred in a limited number of locations on only a few days in 2014.³⁴ Of course, average values for January and February will reflect broader factors than the short-term weather events.
- Gas storage refill rate is not dependent on "coal-to-gas" switching. NCC Report at 11-12. Rather gas gets dispatched in the power sector based on demand and price.³⁵ The gas availability for injection into the transmission system is primarily related to weather dependent gas demand (*e.g.*, winter heating capacity available for injection in the summer).
- The NCC Report also claims "the capacity factor of America's coal plants averages almost 70% while many gas plants could not get fuel this winter and will continue to be replaced by coal throughout the year." NCC Report at 13-14. Gas supply, however, was interrupted only for a matter of days – and certainly not for the rest of the year.³⁶

While the Polar Vortex called attention to fixable flaws in the power system, it did not, as the NCC Report concludes, render essential the future reliance on coal plants that are now set for retirement. The NCC Report notes that those plants scheduled for retirement in the coming years are about 145 MW in size with a heat rate of 10,398.³⁷ These are small, older units. The more enduring contribution the existing coal fleet can make is through larger units retrofit with CCS. These retrofit units can provide a more lasting option to address extreme weather events. During normal operations, these retrofitted coal units would capture CO₂ and keep it from reaching the atmosphere. But on days with extreme weather, the CCS units could be by-passed, providing an additional 20-30 percent increase in power to the system because the units would not experience CCS-related derates.

³³ ICF International, Presentation, "The Polar Vortex and Future Power System Trends," National Coal Council -- 2014 Annual Spring Meeting.

³⁴ *Id.*

³⁵ *Id.*

³⁶ *Id.*

³⁷ NCC Report at 16.

Finally, despite the NCC Report's complaints regarding insufficient time to comply with new regulations, many of the rules cited (MATS, cooling tower rules and coal combustion residual rules, for example) have been pending for well over ten years and the industry has had ample time to accommodate their expected requirements. NCC Report at 10.

4. New Source Review is Not an Impediment to Efficiency Upgrades.

The NCC Report's cursory treatment of the New Source Review ("NSR") regulations and conclusory statements regarding their deterrent effect on efficiency upgrades are misleading. NCC Report at 44-46.

A source undergoing a major modification that results in a significant increase in emissions of a regulated pollutant must go through NSR, 42 U.S.C. § 7475(a), 40 C.F.R. § 51.165(a)(1)(v)(A); and as determined necessary through that process, must apply the best available control technology (or achieve the lowest available emissions limit) as relevant, for the pollutant in question based on the location of the plant. Among other things, the purpose of NSR is to protect public health and welfare and to

assure that any decision to permit increased air pollution in any area to which this section applies is made only after careful evaluation of all the consequences of such a decision and after adequate procedural opportunities for informed public participation in the decisionmaking process.

42 U.S.C. § 7470. These are laudable goals. Improving an existing plant's efficiency, however, *should not* lead to a significant increase in regulated pollutants and therefore should not trigger NSR. The NCC Report assumes that this will occur – based on the increased demand for the more efficient source. But increased hours of operation or production rate increases do not subject a facility to NSR. 40 C.F.R. § 51.165(a)(1)(v)(C)(6), and there is additional flexibility in the regulations for sources operating under a plant-wide applicability limit. 40 C.F.R. § 51.165(f)(1)(v).

Historically, the coal industry has tried to avoid triggering NSR. Unfortunately that attitude continues to be reflected in the NCC Report. In fact, though, compliance with the Mercury Air Toxics Standards ("MATS") and Cross State Air Pollution Rule ("CSAPR") will go a long way toward a source's achievement of the emissions limits that would be required by NSR required controls. Indeed, it is possible, that simply optimizing these control systems will achieve not only the MATS and CSAPR limits but also BACT or LAER – in other words little additional investment in control would result even if NSR review is required for an efficiency upgrade. And, it should go without saying that if a coal-fired power plant is sufficiently under-controlled that it cannot meet MATS and CSAPR, upgrades are appropriate to protect public health and welfare as envisioned under the NSR Program.

5. Conclusions

Mr. Secretary, I drafted this dissent because the NCC Report fails to adequately place the existing coal fleet in the context of our most pressing environmental challenge of the 21st century—climate change. Our nation can't wait. Each year, America's aging coal fleet grows older. With each year, more carbon dioxide is emitted to the atmosphere, and once released, it stays in the atmosphere for periods measured in centuries. And yet, the NCC Report more often emphasizes

what can't be done rather than what can be done to control CO₂ and other air pollutant emissions from the existing fleet, while maintaining its essential character as an important part of our energy backbone.

The existing coal fleet is a long-term asset. With CCS retrofits, the existing coal fleet can be transitioned over time to be a decisive solution to de-carbonizing the electric sector. Indeed, it will be impossible to reach mid-century CO₂ reductions without a backbone of low-carbon base load power that coal with CCS can help provide.

CCS is demonstrated today – for new plants and as a retrofit control on existing power plants. With CO₂ emission limits to support CCS deployment and with incentives to address CCS costs, the technology can be installed rapidly on plants within the existing coal fleet, a point that the NCC Report fails to recognize.

And, finally, retrofitting coal plants in the existing fleet with CCS, allows the fleet to maintain its historic base load advantages to the US economy without harmful CO₂ emissions, and support system reliability during future short-term weather emergencies.

I strongly urge you to consider an expansive set of options that help bring this potential to reality.

Thank you for your consideration,

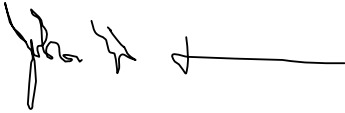
A handwritten signature in black ink, appearing to read 'John Thompson', followed by a horizontal line extending to the right.

John Thompson
Director, Fossil Transition Project
Clean Air Task Force
705 W. Main, Suite 101
Carbondale, IL 62901

APPENDIX G
References

APPENDIX G

References

¹ Annual Energy Outlook – 2014er, USDOE/EIA, December 16, 2013.

² Ibid.

³ Technical Support Document for the Advanced Notice of Proposed Rulemaking for Greenhouse Gases: Stationary Sources, Section VII, USEPA, June 5, 2008, Docketed item # EPA-HQ-OAR-2008-0318-0081.

⁴ The Return on Investment of the Clean Coal Technology Program in the USA, R. Bezdek and R. Wendling, *Energy Policy*, March 2013, Vol. 54, pp. 104-112.

⁵ “By 2050, the Obama administration’s goal is to reduce U.S. greenhouse gas emissions approximately by 83 percent from 2005 levels.” U.S. Climate Action Report, 2010, (the 5th National Communication of the USA under the UNFCCC), June 2010.

⁶ Draft Inventory of U.S. Greenhouse Gas Emissions and Sinks: 1990-2012, USEPA, February 21, 2014.

⁷ Obama Administration Launches Quadrennial Energy Review, The White House, January 9, 2014, <http://www.whitehouse.gov/the-press-office/2014/01/09/obama-administration-launches-quadrennial-energy-review> .

⁸ White House Advanced Manufacturing Initiatives to Drive Innovation and Encourage Companies to Invest in the U.S., The White House, July 17, 2012, <http://www.whitehouse.gov/the-press-office/2012/07/17/fact-sheet-white-house-advanced-manufacturing-initiatives-drive-innovati> .

⁹ Subpart RR Flaws Preclude EPA’s Reliance on CO2-EOR in the Proposed NSPS Rule, Denbury, (undated), quoted by Rep. Weber at hearing of House Environment Subcommittee, Committee on Science, Space, and Technology, March 12, 2014.

¹⁰ Coal to the Rescue, but Maybe Not Next Winter, M. Wald, *New York Times*, March 10, 2014.

¹¹ 2013-2013 Winter Reliability Assessment, North American Electric Reliability Corporation, November 2013 (published December 4, 2013).

¹² Electric Power Monthly – Data through February 2014, USDOE/EIA, April 22, 2014.

¹³ Ibid.

¹⁴ Weekly Working Gas in Underground Storage, USDOE/EIA, http://www.eia.gov/dnav/ng/ng_stor_wkly_s1_w.htm

¹⁵ National Electricity Reliability Corporation, *2013–2014 Winter Reliability Assessment*, November 2013.

¹⁶ Owner reaffirms 2017 closing of Brayton Point Plant, The Boston Globe, January 17, 2014.

¹⁷ 2013 Long-term Reliability Assessment, North American Electric Reliability Corporation, December 2013.

National Coal Council – Reliable & Resilient: The Value of Our Existing Coal Fleet

- ¹⁸ Avoided Energy Supply Costs in New England: 2013, Synapse Energy Economics, Inc., prepared for the Avoided Energy Supply Component Study Group, July 12, 2013.
- ¹⁹ Electric Power Monthly, USDOE/EIA, retrieved as “Net Generation by State”, <http://www.eia.gov/electricity/data/state/>.
- ²⁰ “Coal Unit Shutdowns,” Table 2, American Coalition for Clean Coal Electricity, January 26, 2014.
- ²¹ Process Innovation and Changes in Industrial Energy Use, C. Berg, *Science*, Vol. 199, February 10, 1978.
- ²² Pearl Street Station, IEEE, http://www.ieeeeghn.org/wiki/index.php/Pearl_Street_Station.
- ²³ Paleofuture, <http://paleofuture.gizmodo.com/how-the-1920s-thought-electricity-would-transform-farms-510917940>.
- ²⁴ Data taken from Annual Energy Review, 2011, USDOE/EIA, 2011.
- ²⁵ Annual Energy Outlook 2014, Table A2, USDOE/EIA, December 2013.
- ²⁶ Annual Energy Review 2011, Table 2.1a, USDOE/EIA.
- ²⁷ “Greatest Engineering Achievements of the 20th Century,” U.S. National Academy of Engineering, 2000.
- ²⁸ “The 50 Greatest Breakthroughs Since the Wheel,” James Fallows, *Atlantic*, November 2013, pp. 56-68.
- ²⁹ Data from supporting materials for Annual Energy Review, 2012, USDOE/EIA, 2012.
- ³⁰ *Ibid.*, calculations by author.
- ³¹ Detailed State Data, USDOE/EIA, November 2013, <http://www.eia.gov/electricity/data/state/>.
- ³² Power plant emissions of sulfur dioxide and nitrogen oxides continue to decline in 2012, USDOE/EIA, February 27, 2013, <http://www.eia.gov/todayinenergy/detail.cfm?id=10151>.
- ³³ Regulatory Impact Analysis for the Final Mercury and Air Toxics Standards, Figure 3-6, USEPA, December 2011.
- ³⁴ Public Power Annual Directory & Statistical Report 2013-2014, American Public Power Association.
- ³⁵ Graphics provided by National Rural Electric Cooperative Association, based on 2012 EIA and Rural Electric Service data.
- ³⁶ *Op. Cit.*, Public Power Annual Directory & Statistical Report.
- ³⁷ Climate Policy and Labor Markets, O. Deschenes, Working Paper 16111, National Bureau of Economic Research, June 2010, <http://www.nber.org/papers/w16111>.
- ³⁸ Real Gross Domestic Product, Economic Research, Federal Reserve Bank of St. Louis, <http://research.stlouisfed.org/fred2/series/GDPC1>. All Employees: Total non-farm, <http://research.stlouisfed.org/fred2/series/PAYEMS?cid=32305>.
- ³⁹ Electric Power Monthly – February 2014, USDOE/EIA, 2014. Eurostat database, Electricity and natural gas price statistics, European Commission, http://epp.eurostat.ec.europa.eu/statistics_explained/index.php/Electricity_and_natural_gas_price_statistics.
- ⁴⁰ Data taken from Net Generation by State by Type of Producer by Energy Source (EIA-906, EIA-920, and EIA-923), USDOE/EIA, November 2013, <http://www.eia.gov/electricity/data/state/>.
- ⁴¹ Data taken from Average Price by State by Provider (EIA-861), USDOE/EIA, November 2013, <http://www.eia.gov/electricity/data/state/>.

National Coal Council – Reliable & Resilient: The Value of Our Existing Coal Fleet

- ⁴² Obama Administration Launches Quadrennial Energy Review, The White House, January 9, 2014, <http://www.whitehouse.gov/the-press-office/2014/01/09/obama-administration-launches-quadrennial-energy-review> .
- ⁴³ White House Advanced Manufacturing Initiatives to Drive Innovation and Encourage Companies to Invest in the U.S., The White House, July 17, 2012, <http://www.whitehouse.gov/the-press-office/2012/07/17/fact-sheet-white-house-advanced-manufacturing-initiatives-drive-innovati> .
- ⁴⁴ Electric Power Monthly, March 2014, Table ES2.A, USDOE/EIA, March 21, 2014.
- ⁴⁵ "Energy Weekly," Citi Research, February 10, 2014, <https://www.citivelocity.com> .
- ⁴⁶ "Northeast Switched from Natural Gas to Oil," Institute for Energy Research, February 10, 2014, <http://www.instituteforenergyresearch.org/2014/02/10/northeast-switched-from-natural-gas-to-oil-due-to-lack-of-infrastructure/> .
- ⁴⁷ "West Coast Gas, Power Surge on Frigid Northwest Cold Forecasts," N. Malik, Bloomberg, February 5, 2014.
- ⁴⁸ "Midwest, West Coast Cash Points Spike," A. Steis, Natural Gas Intelligence, February 5, 2014.
- ⁴⁹ Ibid.
- ⁵⁰ "The Economic Impacts of Coal Utilization," A. Rose, et. al., Penn State University, July 2006.
- ⁵¹ CURC/EPRI Roadmap, 2012, Coal Utilization Research Council.
- ⁵² Technical Support Document for the Advanced Notice of Proposed Rulemaking for Greenhouse Gases; Stationary Sources, Section VII, EPA, June 5, 2008, EPA Regulatory Docket No. EPA-OAR-2008-0318-0081.
- ⁵³ "Economic and Jobs Benefits of U.S. Coal Generation," Management Information Services, Inc., prepared for the National Coal Council, March 2014.
- ⁵⁴ Ibid.
- ⁵⁵ Ibid.
- ⁵⁶ Obama Administration Launches Quadrennial Energy Review, The White House, January 9, 2014, <http://www.whitehouse.gov/the-press-office/2014/01/09/obama-administration-launches-quadrennial-energy-review> .
- ⁵⁷ White House Advanced Manufacturing Initiatives to Drive Innovation and Encourage Companies to Invest in the U.S., The White House, July 17, 2012, <http://www.whitehouse.gov/the-press-office/2012/07/17/fact-sheet-white-house-advanced-manufacturing-initiatives-drive-innovati> .
- ⁵⁸ Real Gross Domestic Product, US Department of Commerce, Bureau of Economic Analysis.
- ⁵⁹ Data from supporting materials for Annual Energy Review, 2012, USDOE/EIA, 2012.
- ⁶⁰ Data from Annual Energy Outlook, 2014 early release, Reference Case, USDOE/EIA, December 2013.
- ⁶¹ The Society of Manufacturing Engineers concluded that "We are not going to get out of this economic crisis without a strong, innovative manufacturing sector," *Manufacturing Business Technology*, April 23, 2009. www.mbtmag.com; see also, Nina Ying Sun, "U.S. Manufacturing Vital to Crisis Recovery," February 22, 2009, <http://plasticsnews.com>; James W. Owen, "The Financial Crisis and the U.S. Economy – a CEO's Perspective," Council on Foreign Relations, Washington, D.C., April 2009; and Susan Helper, "The High Road for U.S. Manufacturing," *Issues in Science and Technology*, Winter 2009. To the extent that a global recovery will require a rebalancing of trade – the U.S. deficit must be reduced as China's surplus must fall – the U.S. will suffer a decline in living standards, since the U.S. will be producing more than it has been consuming, unlike the previous decades when the U.S. was consuming more than it

National Coal Council – Reliable & Resilient: The Value of Our Existing Coal Fleet

was producing. This impact on living standards will be apart from any negative impact on living standards owing to U.S. citizens paying higher energy costs.

⁶² Natural gas generation lower than last year because of differences in relative fuel prices, USDOE/EIA, September 25, 2013, <http://www.eia.gov/todayinenergy/detail.cfm?id=13111> .

⁶³ US natural gas spot prices increased during first-half 2013, USDOE/EIA, July 22, 2013, <http://www.eia.gov/todayinenergy/detail.cfm?id=12191> .

⁶⁴ The State of the National Pipeline Infrastructure, USDOT, October 2011.

⁶⁵ Based on data published by USDOE/EIA in AEO Retrospective Review: Evaluation of 2012 and Prior Reference Case Projections, March 15, 2013, <http://www.eia.gov/forecasts/aeo/retrospective/> (and similar data from the AEO Retrospective Review for AEO-2008).

⁶⁶ Based on analysis of data published by Sourcewatch, http://www.sourcewatch.org/index.php/Coal_plant_retirements , accessed March 6, 2014.

⁶⁷ Office of Information and Regulatory Affairs, Office of Management and Budget, <http://www.reginfo.gov/public/jsp/EO/eoDashboard.jsp> .

⁶⁸ Presidential Memorandum – Power Sector Carbon Pollution Standards, The White House, June 25, 2013.

⁶⁹ “By 2050, the Obama administration’s goal is to reduce U.S. greenhouse gas emissions approximately by 83 percent from 2005 levels.” U.S. Climate Action Report, 2010, (the 5th National Communication of the USA under the UNFCC), June 2010.

⁷⁰ Climate Change 2014: Mitigation of Climate Change – Summary for Policy Makers, IPCC Working Group III, April 2014.

⁷¹ Database of State Incentives for Renewables & Efficiency, website hosted by the North Carolina Solar Center, http://www.dsireusa.org/documents/summarymaps/RPS_map.pdf .

⁷² AEO2014 projects more coal-fired power plant retirements by 2016 than have been scheduled, USDOE/EIA, February 14, 2014, <http://www.eia.gov/todayinenergy/detail.cfm?id=15031> .

⁷³ AEO2013, Online Table Browser, USDOE/EIA, 2013.

⁷⁴ New Source Review for Stationary Sources of Air Pollution, National Research Council, 2006.

⁷⁵ See, e.g., 40CFR51.21.

⁷⁶ Op.Cit., NRC, 2006, Table 2-3.

⁷⁷ New Source Review: Report to the President, USEPA, June 2002.

⁷⁸ Ibid., p.16.

⁷⁹ Ibid., p.16.

⁸⁰ Letter from Francis X. Lyons, Regional Administrator, EPA, to Henry Nickel (May 23, 2000) (“Detroit Edison Determination”) (emphasis added), *available at* www.epa.gov/ttn/nsr/gen/letterf3.pdf.

⁸¹ Ibid., p. 27.

⁸² Ibid.

⁸³ Ibid.

⁸⁴ Ibid., p. 21-22.

National Coal Council – Reliable & Resilient: The Value of Our Existing Coal Fleet

⁸⁵ Data for Figures 15-17 are taken from responses to EIA Form 860, as published by DOE/EIA, <http://www.eia.gov/electricity/data.cfm> .

⁸⁶ FY2015 Summary Control Table by Organization, USDOE, <http://energy.gov/cfo/downloads/fy-2015-budget-justification> .

⁸⁷ Electric Power Monthly, USDOE/EIA, February 2014.

⁸⁸ The Return on Investment of the Clean Coal Technology Program in the USA, R. Bezdek and R. Wendling, *Energy Policy*, March 2013, Vol. 54, pp. 104-112.

⁸⁹ See, for example: Mitigating the Effects of Flexible Operation on Coal-Fired Power Plants, S. Hesler, EPRI, *Power Magazine*, August 1, 2011; and Managing Large-Scale Penetration of Intermittent Renewables, MIT, April 20, 2011, <https://mitei.mit.edu/system/files/intermittent-renewables-full.pdf> .

⁹⁰ Impacts of Wind Generation Integration, EPRI, May 6, 2011, <http://www.epri.com/abstracts/pages/productabstract.aspx?ProductID=00000000001023166> .

⁹¹ Wind Assisted Heating, P. Staffes, http://www.google.com/url?sa=t&rct=j&q=&esrc=s&frm=1&source=web&cd=1&cad=rja&uact=8&ved=0CCoQFjAA&url=http%3A%2F%2Fwww.steffes.com%2FLiteratureRetrieve.aspx%3FID%3D60620&ei=bjleU9jrFM_woATSv4DwCg&usq=AFQjCNHkKjBiT99Ok75SDLIVbsOhGRJ0uw&sig2=e7MrB0QWAEzVWxo4n3NPtQ&bvm=bv.62788935.d.cGU .

⁹² Western Wind and Solar Integration Study, GE Energy for National Renewable Energy Laboratory, May 2010.

⁹³ Based on analysis of data published by Sourcewatch, http://www.sourcewatch.org/index.php/Coal_plant_retirements , accessed March 6, 2014.

⁹⁴ Northeast's Record Natural Gas Prices Due to Pipeline Dearth, Bloomberg Businessweek, February 6, 2014, <http://www.businessweek.com/articles/2014-02-06/northeast-s-record-natural-gas-prices-due-to-pipeline-dearth> .

⁹⁵ Available and Emerging Technologies for Reducing GHG Emissions from Coal-Fired Electric Generating Units, EPA/OAR, Oct 2010.

⁹⁶ Remote Monitoring and Diagnostics Within a Smart Integrated Infrastructure, U. Nowling, *Power Magazine*, Vol 158, No. 2, February 1, 2014.

⁹⁷ DryFining Fuel Enhancement Process, Great River Energy, 2013, available at <http://www.greatriverenergy.com/makeelectricity/newprojects/dryfining.html>

⁹⁸ Clean Coal Technology, Professor Sunggyu Lee's Research Program at Ohio University, <http://www.ohio.edu/people/lees1/coal.html> .

⁹⁹ Lopriore, R., PSEG President - Fossil, Personal Communication, February 14, 2014.

¹⁰⁰ Coal-fired Power Plant Heat Rate Reduction, Sargent & Lundy final Report SL-009597, January 22, 2009, prepared for EPA Project 12301-001. Table 4-3.

¹⁰¹ Ibid.

¹⁰² Op. Cit., Sargent & Lundy.

¹⁰³ A Review of upgrading and efficiency improvement projects on coal-fired power plants, workshop on upgrading and efficiency improvements in coal-fired power plants, Henderson, C., E.On Engineering Academy, Ratcliffe-on-Doar, March 2013.

¹⁰⁴ Power Generation from Coal – Measuring and Reporting Efficiency Performance and CO2 Emissions, CIAB/International Energy Agency, 2010.

National Coal Council – Reliable & Resilient: The Value of Our Existing Coal Fleet

¹⁰⁵ Op. Cit., Sargent & Lundy.

¹⁰⁶ Ibid.

¹⁰⁷ Advanced Sensors and Controls – Techno-Economic Analysis for Existing Coal Generating Units, DOE/NETL-342/03082013, March 8, 2013.

¹⁰⁸ 21st Century Coal: Advanced Technology and Global Energy Solution, Report by the IEA Coal Industry Advisory Board, Paris, 2013.

¹⁰⁹ MHI High Efficiency System – Proven technology for multi pollutant removal, Y. Nakayama, et. al., Mitsubishi Heavy Industries, Ltd., <http://www.advatechllc.com/wp-content/uploads/2012/03/High-Efficiency-System-Proven-Technology-for-Multi-pollutant-Removal-Paper.pdf> .

¹¹⁰ Cost and Performance Baseline for Fossil Energy Plants: Volume 1: Bituminous coal and Natural Gas to Electricity, Revision 2a, September 2013, DOE/NETL -2010/1397. See Exhibit 4-34.

¹¹¹ Op. Cit., Sargent & Lundy.

¹¹² Development tendency analysis of (ultra-) supercritical fossil fired power plants in China, Long H. et. al., undated.

¹¹³ The Applicability of Supercritical Topping Cycles for Repowering Subcritical Steam-Electric Power Plants, EPRI Technical Update Report 1019677, December 2010.

¹¹⁴ Steigelmann, W. et. al., “CHP Bottoming-Cycles: An “Outside-the-Box”

¹¹⁵ Power Generation from Coal – Measuring and Reporting Efficiency Performance and CO2 Emissions, CIAB/International Energy Agency, 2010.

¹¹⁶ Ibid.

¹¹⁷ Transcript of Press Conference by Press Secretary R. Gibbs and Assistant to the President for Energy and Climate Carol Browner, (climate statement by Ms. Browner), The White House, November 25, 2009, <http://www.whitehouse.gov/the-press-office/press-gaggle-press-secretary-robert-gibbs-deputy-national-security-advisor-internat>

¹¹⁸ Draft Inventory of U.S. Greenhouse Gas Emissions and Sinks: 1990-2012, USEPA, February 21, 2014.

¹¹⁹ \$2.3 B from annual appropriations and \$3.4B from the American Recovery and Reinvestment Act, Carbon Capture and Sequestration: RD&D at the U.S. Department of Energy, Congressional Research Service, April 23, 2013.

¹²⁰ Renewable Energy and Energy Efficiency Incentives: A Summary of Federal Programs, Appendix A, Congressional Research Service, R40913, October 18, 2013.

¹²¹ Based on 168 million MWh of wind generation (from DOE/EIA Electric Power Monthly – Feb 2014, and Production Tax Credit of 2.3 cents per kWh (IRS Form 8835).

¹²² Low-Carbon Coal: Meeting U.S. Energy, Employment and CO2 Emission Goals with 21st Century Technologies, National Coal Council, December 2008; and Expediting CCS Development: Challenges and Opportunities, National Coal Council, March 2011.

¹²³ “Alstom would also point out that it is unaware that any supplier of this technology is ready or able to offer commercial guarantees for such full-scale systems of carbon capture.” Testimony of R. Hilton, before the U.S. House of Representatives Subcommittee on Environment and Subcommittee on Energy, of the Committee on Science, Space, and Technology, March 12, 2014.

¹²⁴ EPA Utility FGD survey: October –December 1979, Smith, M. et. al., EPA-600/7-80-029a, January, 1980.

National Coal Council – Reliable & Resilient: The Value of Our Existing Coal Fleet

¹²⁵ *Trends In Commercial Application of FGD Technology*, Laeske, B. et. al., Proceedings: Symposium on Flue Gas Desulfurization, Volume 1, EPRI CS-2897, March 1982

¹²⁶ [Uncertainties in Technology Experience Curves for Energy-Economic Models](http://www.cmu.edu/epp/iecm/rubin/PDF%20files/2010/Yeh&Rubin_Uncertainties%20in%20Experience%20Curves_18May2010.pdf), S. Yeh & E. Rubin, CMU, 2010, http://www.cmu.edu/epp/iecm/rubin/PDF%20files/2010/Yeh&Rubin_Uncertainties%20in%20Experience%20Curves_18May2010.pdf .

¹²⁷ [Clean Coal Research Program – Carbon Capture Technology Program Plan](#), (pages 19-20), USDOE/NETL, January 2013.

¹²⁸ [Low-Carbon Coal: Meeting U.S. Energy, Employment and CO₂ Emission Goals with 21st Century Technologies](#), National Coal Council, December 2008; and [Expediting CCS Development: Challenges and Opportunities](#), National Coal Council, March 2011.

¹²⁹ R&D Update, DOE/NETL 2011

¹³⁰ DOE Issues Final EIS for W.A. Parish, GHG Monitor, March 13, 2013, available at <http://ghgnews.com/index.cfm/doe-issues-final-eis-for-wa-parish/>

¹³¹ [White Rose Project Fact Sheet](http://sequestration.mit.edu/tools/projects/white_rose.html), CCS Database, MIT, http://sequestration.mit.edu/tools/projects/white_rose.html .

¹³² [OXYCFB 300 Compostilla Project](http://www.globalccsinstitute.com/project/oxycfb-300-compostilla-project), Fact Sheet stating that the proposed 300 MW demonstration project is considered cancelled, Global Carbon Capture and Storage Institute, <http://www.globalccsinstitute.com/project/oxycfb-300-compostilla-project> .

¹³³ The United States 2012 Carbon Utilization and Storage Atlas, Fourth Edition, Department of Energy, Office of Fossil Energy, available at http://www.netl.doe.gov/technologies/carbon_seq/refshelf/atlasIV/. Hereafter 2012 Carbon Atlas

¹³⁴ National Assessment of Geologic Carbon Dioxide Storage Resources – Results, Circular 1386, Version 1.1, September 2013. Hereafter USGS September 2013

¹³⁵ *The Global Status of CCS: 2013*, Global CCS Institute, August 2013, page 15.

¹³⁶ Technology Roadmap: Carbon Capture and Storage, 2013 Edition, International Energy Agency, page 17.

¹³⁷ *The North American Carbon Storage Atlas – 2012, First Edition*, page 18. Available at www.nacsap.com.

¹³⁸ *Improving Domestic Energy Security and Lowering CO₂ Emissions with Next Generation CO₂-Enhanced Oil Recovery (CO₂-EOR)*, Report DOE/NETL-2011/1504, June 20, 2011.

¹³⁹ Improving Domestic Energy Security and Lowering CO₂ Emissions with “Next Generation” CO₂-Enhanced Oil Recovery (CO₂-EOR), Report DOE/NETL-2011/1504, June 20, 2011.

¹⁴⁰ [Subpart RR Flaws Preclude EPA’s Reliance on CO₂-EOR in the Proposed NSPS Rule](#), Denbury, (undated), quoted by Rep. Weber at hearing of House Environment Subcommittee, Committee on Science, Space, and Technology, March 12, 2014.

¹⁴¹ [Low-Carbon Coal: Meeting U.S. Energy, Employment and CO₂ Emission Goals with 21st Century Technologies](#), National Coal Council, December 2008; and [Expediting CCS Development: Challenges and Opportunities](#), National Coal Council, March 2011.

¹⁴² [Report of the Interagency Task Force on Carbon Capture and Storage](http://energy.gov/sites/prod/files/2013/04/f0/CCSTaskForceReport2010_0.pdf), (multiple agencies), August 2010, http://energy.gov/sites/prod/files/2013/04/f0/CCSTaskForceReport2010_0.pdf .